



# INSTALLATION AND OPERATOR'S MANUAL

COAL GUN™ BOILER

Models: S130 • S260



**IMPORTANT:** IN ORDER TO ACHIEVE SAFE AND SATISFACTORY RESULTS FROM YOUR ALTERNATE HEATING SYSTEMS BOILER, READ SAFETY RULES AND INSTRUCTIONS CAREFULLY BEFORE INSTALLING AND OPERATING. ALL INSTALLATIONS MUST BE IN ACCORDANCE WITH STATE AND LOCAL CODES. SAVE THESE INSTRUCTIONS FOR FUTURE REFERENCE.



Your Alternate Heating Systems Boiler is capable of generating very hot temperatures. Boiler temperatures and flames in the ignition box area are capable of causing ignition or explosion of explosive or flammable products or explosion of the boiler itself if maximum safe water temperature is exceeded. Maximum safe water temperature is 210° Fahrenheit. Flammable or explosive products must never be stored in the same room or in the vicinity of a boiler, and the boiler water temperature must never be allowed to exceed 210° Fahrenheit.

**ALTERNATE HEATING SYSTEMS**  
2393 LITTLE EGYPT RD  
HARRISONVILLE, PA 17228  
717-987-0099  
WWW.ALTERNATEHEATINGSYSTEMS.COM  
EMAIL: SERVICE@WOODGUN.COM

**Record Model and Serial Number Below:**

**Model:**  
**Serial Number:**  
**Date of Purchase:**



Copyright 2015 Alternate Heating Systems

No portion of this publication may be reproduced without the express written consent of Alternate Heating Systems.

Printed: 12/26/17

Coal Gun boilers are optionally available with the ASME H stamp.

It is the customer's responsibility to determine whether the boiler must include the stamp to satisfy local code requirements.



Coal Gun boilers bearing the mark seen at right are thereby designated as compliant.

The Coal Gun™ has undergone thorough testing and is certified to the Underwriter's Laboratories test standard 5253-2009 and Canadian Test Standard: CSA B366.1-2011





# Table of Contents

Introduction.....	1
Boiler Installation.....	2
boiler location.....	2
Boiler Room Requirements.....	2
Rigging and Positioning of Boiler.....	2
Clearances Required for Safety and Operation.....	3
General Chimney Introduction.....	3
Draft.....	4
Technical Aspects of Chimney Performance.....	4
Barometric Damper - Draft Controls.....	5
How Draft Controls Work.....	6
Choosing the Right Size Draft Control.....	6
Stovepipe.....	7
Proper Chimney Connection.....	7
Wall Pass-Through: United States.....	9
Wall Pass-Through: Canada.....	9
Chimney Requirements.....	9
Masonry Chimneys.....	10
Prefabricated Chimneys.....	10
In case of chimney fire.....	11
In case of runaway fire.....	11
Combustion Air Supply.....	11
Boiler Piping for Hydronic Systems.....	12
Piping the Boiler in Parallel with another Boiler.....	12
Checklist: When the Boiler is Added to an Existing System.....	12
Pressure Relief Valve.....	13
Pressure Reducing Auto Fill.....	13
Expansion Tank.....	13
Low Water Cutoff.....	13
Boiler Conditioner / Sealant.....	13
Boiler Piping and Controls for Steam Systems.....	14
Forced Hot Air Systems (Water to air Coil in Duct).....	14
Domestic Hot Water Coil Piping.....	14
Illustrated Instructions for Installing Coal Hopper on S130 and S260.....	15
Electrical Connections in the Coal Gun™.....	16
S130/S260 Power Requirements.....	16
Power Connections.....	16
Controls.....	17
Aquastat Controls.....	17
Mode Switch & Ash Removal.....	17
Thermal Ash Monitor Settings.....	17
Grate Timers and Settings.....	18
Thermostat Connection.....	20
Steam.....	20
Boiler Dump Zone Applications.....	20
Non Powered Dump Zone.....	20
Operating Information.....	22
Lighting the Coal Gun™.....	22
Warning- Risk of fire:.....	22

Caution.....	23
Operation of Sight Hole Flap.....	23
Shutting Down the Coal Gun.....	24
Automatic Fuel Delivery Systems.....	24
Basic Auger Operation.....	24
Auger assembly.....	25
Thermo Ash-Monitoring Grate Control Operation.....	25
Fuel storage / Removal and Disposal of Ashes.....	25
treatment of Boiler Water.....	26
Ph.....	26
Dissolved Oxygen.....	26
Sulfites.....	26
Solids.....	26
Alkalinity.....	27
Phosphates.....	27
Hardness.....	27
Oils.....	27
Antifreeze.....	27
Appendix A: Boiler Specification Diagrams.....	28
Additional Specifications.....	30
Pressure Drop.....	30
Explanation of GPM Flow.....	30
Appendix B: Wiring Diagrams.....	31
Appendix C: Exploded Parts Drawing.....	34
Parts Listing.....	35
Appendix D: Maintenance.....	36
End of season cleaning.....	36
Cleaning Exhaust End of Swirl Tube.....	36
Cleaning Rear of Heat Exchanger.....	37
Cleaning coal pot, feed tube and grate.....	38
Fan Assembly Removal/Repair.....	39
Direct Drive Motor Bearing Replacement.....	41
Additional Information.....	43
Operation and Maintenance Schedule for Models S130 and S260.....	44
Appendix E: Troubleshooting Guide.....	45
Checking/Removing Clinkers.....	47
Appendix F: Table of Figures.....	48
Appendix G: Programming Grate Control.....	49
Dwyer 16C-2 Programming.....	50
Initial Programming.....	50
LOCKING CONTROL.....	50
Appendix H: Dump Zone Wiring Applications.....	51
Appendix I: Boiler Piping Examples.....	57
LIMITED WARRANTY.....	60

# Introduction

The purpose of this manual is to assist you in the installation, operation and maintenance of your new boiler in order to achieve the best performance possible. The boiler unit shall be installed by a qualified and experienced boiler installation technician who has a thorough knowledge of hydronic heating systems and boilers and will comply with all requirements of AHS. Should your installation require a steam boiler, it is even more important that experienced personnel be consulted to ensure that the necessary safety controls are installed and properly wired.

Read the entire instruction manual carefully and understand it thoroughly before installing or operating this unit. Save these instructions and review them periodically to refresh your memory regarding safe operating practices and routine maintenance required.

All Alternate Heating Systems Boilers can be supplied with the ASME “H” stamp and National Board number for an additional fee when requested prior to purchase. Alternate Heating Systems boilers are built to rigid quality control standards. You can be assured of receiving a high quality product.

# Boiler Installation

---

## BOILER LOCATION

---

Coal Boilers radiate heat from multiple surfaces. This heat can be dangerous if the boiler is improperly installed. The boiler must stand on a noncombustible material such as brick, stone tile or concrete. NEVER place a boiler directly on a wood floor. The noncombustible material upon which the boiler stands should extend at least 12 inches beyond the base of the boiler in the rear and on the sides and at least 36 inches in front. The boiler must be installed in an area dedicated to the boiler and its related equipment. This area must be partitioned or separated from any living area of a residence. The room must have a constant fresh air supply to assure proper combustion of the fuel as well as ventilation of any by-products of combustion.



## Boiler Room Requirements

- ✓ Must have adequate lighting, and should include a source of emergency light.
- ✓ A convenient water supply should be available for boiler flushing and to clean the boiler room floor.
- ✓ Unobstructed floor drains should be available.
- ✓ Must not be installed where there is the possibility of the accumulation of explosive vapors.
- ✓ Must have adequate air supply, which must be kept clear and unobstructed at all times. Since the combustion process requires a

continuous supply of air, it is essential that provisions are made to supply adequate air to the boiler room. This air supply is necessary to insure complete combustion and venting of any gases or smoke that would be emitted from this solid fuel-burning boiler in case the boiler malfunctions.



- ✓ Electrical disconnect at point of entrance to boiler room.
- ✓ Walls and ceiling must be of fire-rated construction. Consult local or state codes for requirements.
- ✓ Use a Carbon Monoxide detector to monitor CO levels. Include one in the boiler room and at knee level within living areas in the home as well.

---

## RIGGING AND POSITIONING OF BOILER

---

Do not attempt to move or off-load the boiler without the aid of a crane or dolly. All Alternate Heating Systems boilers have at least one lifting lug in the center of the top. On some units lifting lugs in the front and rear are provided. Use caution whenever moving a boiler. When choosing the equipment to move and/or position the boiler, always be sure of the load rating on the equipment prior to use.



A ratchet puller (come along) device may be needed to move a boiler where the ground level changes in elevation. AHS suggests that professional movers should be used in any unpredictable situation. This is to prevent damage to the product, property, and to eliminate the potential for bodily injury.

Once the boiler is on the floor level where it will be installed, the unit may be rolled on pipe or may be moved by means of a pallet jack. Use of a pallet jack with the Coal Gun™ requires that the boiler be skidded or that the installer has made other provisions to insert a pallet jack under the boiler base without causing damage. The boiler must be placed on a concrete slab or other rigid pad of non-combustible material with sufficient strength to adequately support the boiler, including its contents of water. The boiler should be positioned as closely as possible to the chimney. The smoke pipe must pitch continually upward toward the chimney and contain as few elbows as possible. Level the boiler after it has been positioned.

Before proceeding with installation, inquire with local building officials to ensure that the installation is in compliance with all building, plumbing and electrical codes.

A qualified technician experienced in boiler installations is recommended for the installation of this unit. Wiring on the boiler must be properly grounded.

**NOTE: This unit is not approved or recommended for use in mobile homes.**

---

## CLEARANCES REQUIRED FOR SAFETY AND OPERATION

---

It is important to provide sufficient clearance around the boiler for convenient servicing and cleanout. The required minimums for Coal Stoker boilers when measured from the exterior of the boiler are:

- **Rear:** 30 inches to the rear (end of boiler with fan assembly)
- **Right Side:** 36 inches to the right side (when facing the front of the boiler)
- **Left side:** 16 inches
- **From hopper top:** 18 inches
- **Front:** 24 inches, (end of boiler with sight tube)

For commercial and residential installations, many boiler codes require a minimum of 3 feet of clearance on all sides. It is the customer's responsibility to determine whether the installation complies with local code or insurance company requirements. Refer to Appendix A: Boiler Specification Diagrams for exterior dimensions of the various models.

---

## GENERAL CHIMNEY INTRODUCTION

---

One of the most important considerations in installing a coal burning boiler is the type of chimney that will be used. The condition and construction of the chimney is important for providing sufficient draft. The Coal Gun produces its own draft during the on cycle (when the induction fan is running), but the chimney produces the draft during the off cycle. It is necessary to have continual draft during the off cycle, in order to move combustion byproducts carbon dioxide/monoxide, sulfur dioxide and other gases out of the boiler.

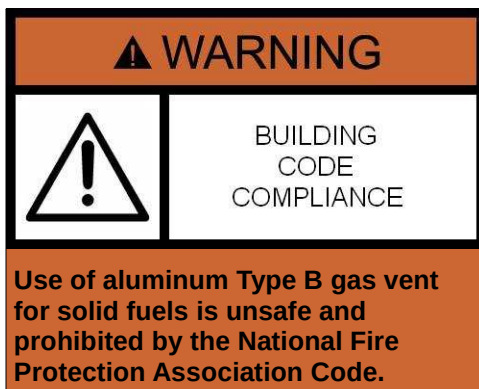

**NOTE: For insurance and building code compliance check with your local building inspector and insurance agent.**

## Draft

Natural draft in a chimney results from several factors. The main characteristic of draft is lower pressure at the top opening of the chimney than further down. This can be created by air currents blowing across the top of the chimney. In addition, draft is also produced when the temperature of the flue gases is higher than the atmosphere around the chimney. This is known as the stack effect. A chimney must be kept warm (about 250° F) for proper draft to occur. A chimney's height, expressed as the difference between the top opening and the flue pipe connection on the appliance, contributes to draft because atmospheric pressure is naturally lower at the chimney top than bottom. See Draft Control section in this manual for more information.

It is more difficult to maintain sufficient temperature in an exposed chimney, or one that is very large, than a chimney that is protected from outside temperature extremes. For this reason, insulated chimneys typically provide more draft, due to increased stack effect. A chimney with a large cross-sectional area may have difficulty becoming warm enough to produce good draft, because gases cool too much before exiting the chimney.

The chimney must be sufficiently tall (at least 20 feet for masonry chimneys) and should extend at least three feet above the highest part of the roof to prevent downdrafts. The chimney must be leak-free from the standpoint of air entering through cracks or other chimney defects or through loose stovepipe fittings.

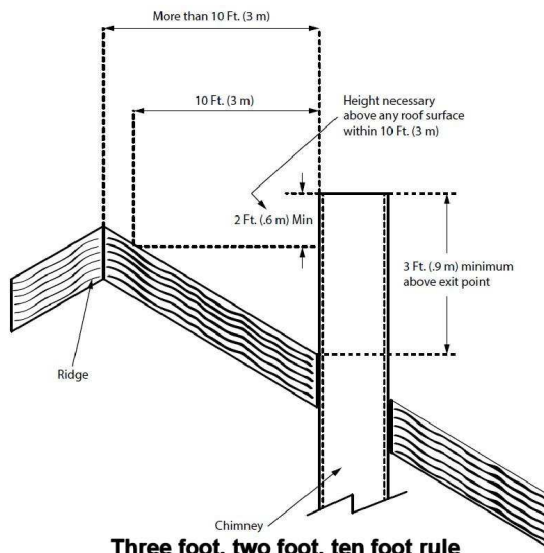

**Three foot, two foot, ten foot rule**  
**3-2-10 Rule for Chimneys**

If the chimney must go through a combustible wall, be sure to use a metal thimble specially designed for this purpose. The proper way to install a thimble is to cut an oversize hole in the sheetrock about 6 or 7 inches larger than the thimble (refer to Figure 2). However, be sure to follow the manufacturer's directions that come with the thimble. A metal ring shield is used to cover the hole. This way air can circulate and cool the area around the passageway.

Never decrease the cross-sectional area of the stovepipe/chimney because the velocity of the exhaust will increase thus increasing the likelihood of particle discharge in the exhaust.

## Technical Aspects of Chimney Performance

A device called a manometer is used in describing the technical performance of a chimney. A manometer is an instrument used for measuring the pressure of liquids and gases. An analog manometer consists of a glass tube filled with a liquid and mounted in front of a measuring scale against which the liquid level can be measured. If a manometer were connected to a leak-free chimney with a leak-free connection, then the draft in the chimney should exert enough pressure (or pull) against the water in the manometer to cause it to move at least 0.04 inches in the tube.

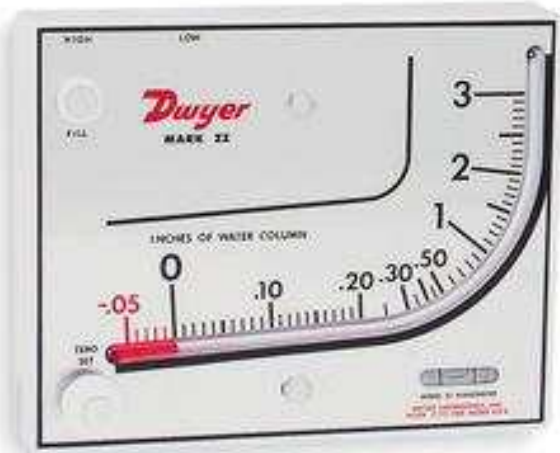

Dwyer Manometer



Barometric Damper

## BAROMETRIC DAMPER - DRAFT CONTROLS

**Note: Do NOT use a barometric damper unless excessive draft (in excess of -.08 inches of water column) is present.**

**NOTE: The information in the rest of this section is provided by Field Controls, LLC, Kinston, North Carolina, 252.522.3031. This information is used with their permission. Some information may not apply to coal burning systems. The information is taken from Field Controls, LLC website at: [www.fieldcontrols.com/draftcontrol.php](http://www.fieldcontrols.com/draftcontrol.php). See the Field Controls website for specific models of draft controls or to place an order.**

Where excessive natural draft exists, a barometric damper is required to prevent the boiler from overheating. Do not operate the Coal Gun with flue draft exceeding -.08 inches of water column. The likelihood of this condition increases with increased chimney height. Shorter chimneys may not require a barometric damper. Other aspects of chimney construction, such as the smoothness of the inner surface of the liner and the type of liner material used can impact draft. Liners that resist heat flow through the liner improve draft by keeping the chimney warmer. Warm outdoor temperatures will decrease draft while colder ones will increase draft. Windy days will generally result in more variation in measured draft. Be aware of these environmental impacts on draft during changes in the seasons between fall and winter, and winter and spring. It is best to measure draft before concluding whether a control is required or not. Excessive draft can lead to an over-firing condition. A correctly installed draft control can prevent this.

The standard type “M” field control with a “T” is recommended for satisfactory performance. For proper operation and efficient fuel consumption in oil, gas and/or coal-fired heating appliances, draft must remain relatively constant, and above -.04 inches water column, as measured with a manometer. Proper draft will normally result in greater efficiency, with less heat wasted by escaping through the vent (chimney).

Field draft controls maintain consistent draft by counteracting the negative forces caused by changes in temperature and barometric pressure, and the effects of wind. The draft should be checked with a draft meter in the flue pipe two to three feet above the boiler and before the barometric damper.



**NOTE:** See diagram below which has been modified for this manual.

### How Draft Controls Work

1. Static pressure from the cooler air around the boiler exerts pressure on the outside of the furnace or boiler, the breaching, and the stack.
2. The pressure difference between the room air and hot exhaust gasses causes products of combustion to flow (draft) through the unit and to rise through the breaching and chimney.
3. When draft reaches a value higher than the setting of the control, room temperature air enters through the barometric draft control in the precise amount needed to overcome the excess drafts caused by temperature variations, wind fluctuations and barometric pressure changes.
4. Combustion of fuel is completed and the process is stabilized. The velocity of combustion gases through the heat exchanger is slowed so more heat is extracted. The unit operates more efficiently, reliably and requires less maintenance.

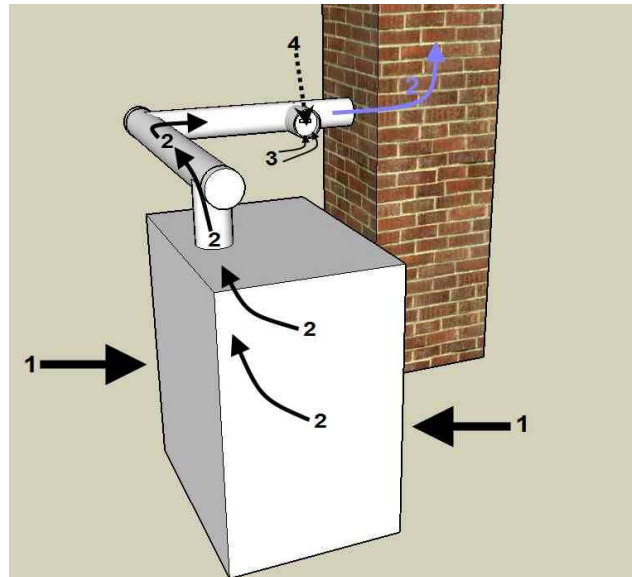

**Draft Control**

### Choosing the Right Size Draft Control

If a barometric damper is required, use these simple rules of thumb to guide size selections:

1. Use a draft control the same size as the flue pipe, that is, a 6" control for a 6" round pipe, a 12" control for a 12" pipe, etc.
2. For intermediate sizes of smoke pipe, use the next larger size draft control to provide ample capacity. It is a simple matter to install a round control on a pipe an inch or so larger or smaller than the control.
3. If the flue pipe or breaching is square, use the round equivalent. For example - on a 14" x 14" breaching use a 14" control. Little flow occurs in the corners of a square pipe so that its capacity is approximately the same as a round pipe of the same diameter.
4. If the breaching is rectangular or oval, compute its cross-sectional area and select a draft control having the same or a greater nominal cross-sectional area. A breaching 14" high x 10" wide would have a cross-sectional area of 140 square inches. From the table, select a 14" control with a cross-sectional area of 154 sq. inches.

5. Where a control larger than 32" is required, use more than one regulator with combined cross-sectional areas equal to or greater than that of the

breaching. When chimneys are of an unusual height or if the draft to be maintained is either very high or very low, it is advisable to deviate from the rules of thumb outlined here. Refer to the larger table (following page).

Control Size	Nominal Cross-Sectional Area (Sq. In.)
6"	28
7"	38
8"	50
9"	63
10"	78
12"	113
14"	154
16"	201
18"	255
20"	314
24"	452
28"	616
32"	804

**Note: Manually operated dampers must not be used with the Coal Gun**

Warm outside temperatures will result in decreased draft. This can lead to operational concerns related to poor draft. Changes may be needed when transitioning between seasons and warm outside temperatures result in poor draft, or vice versa, when cold outdoor temperatures result in increased draft. It sometimes necessary to add a draft inducer in warmer seasons to maintain the recommended -.04 to -.08 inches of water column.

**⚠ CAUTION**

	<p>SUFFOCATION HAZARD</p>
---	-------------------------------

**The airflow through the system and out the chimney means that oxygen is leaving the home and will create an oxygen deficit if this air is not replaced.**

The airflow through the system and out the chimney means that oxygen is leaving the home and will create an oxygen deficit if this air is not replaced. There is usually sufficient leakage in older homes, but in well-insulated homes it may be necessary to provide additional outside air into the home.

### Stovepipe

Use only 22-24 gauge single wall stove pipe in open areas that are no closer than 18 inches from walls or ceiling. If the stovepipe must be closer than 18 inches from the nearest wall or ceiling, or if it must go through walls, closets, or boxed in areas, then UL listed insulated stovepipe must be used. Stovepipe that runs along the outside walls of a building must also be UL listed insulated pipe, even if it runs along a non-combustible outside wall. This requirement is in place in order to prevent cooling of the stovepipe, which in turn cools the rising smoke and causes creosote to form quickly (however, this provision does not apply to the Coal Gun because there is not sufficient gas generated in the exhaust to cause creosote).

### Proper Chimney Connection

The boiler must be connected to a listed type HT prefabricated or masonry chimney. For connecting pipe, 24 gauge black or blued or stainless steel is the minimum requirement. Stainless steel is recommended for durability, preferably 300 series

(304 or 316). The minimum flue diameter for an S130 is 5 inches and an S260 is 6 inches.

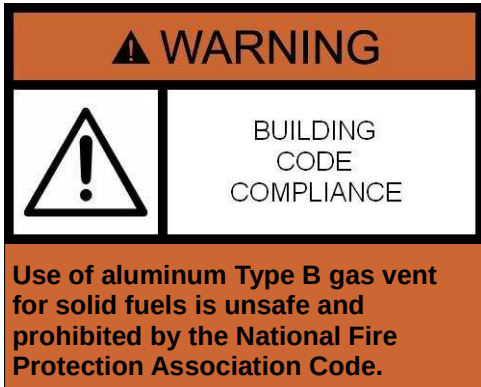

The recommended method for connecting the boiler to the chimney is as follows: Use a 5 inch diameter pipe (6 inches for the S260) to connect to the flue opening on the top of the boiler. This pipe will go on the inside of the opening of the exhaust flange.



**Flue Pipe Connection**

It is best to place a T-joint at the top of the vertical section leading from the breach (exhaust) flange. The rear opening must be covered with a cap, which can be removed for cleaning and inspection without disturbing the rest of the pipe. The inclusion of a horizontal run must feature provision for pipe disassembly, inspection and removal of any fly ash

that accumulates. If the horizontal run to the chimney is inclined more steeply, it will encourage any fly ash that would otherwise be deposited in the pipe to fall back into the ash separator. The minimum rise is a quarter inch per foot of horizontal run. Ensure that there is at least 18" clearance between horizontal piping and combustible ceiling. Ensure that the chimney connection pipe extends at least 2" into the chimney, but does not extend so far into the chimney that it blocks airflow. A "T" should always be used where the stovepipe changes directions (rather than an elbow) to allow for easy cleanout. Do NOT connect this unit to a chimney flue serving another appliance.

If a second change of direction is required before entering the chimney, a cleanout "T" should be placed at this point also, as indicated in Figure 1. Each joint should be secured with three sheet metal screws and sealed with high temperature sealant capable of withstanding 650° F. If the selected stove pipe contains seams, these may also need to be sealed. Use of aluminum Type B gas vent for solid fuels is unsafe and prohibited by the National Fire Protection Association Code.

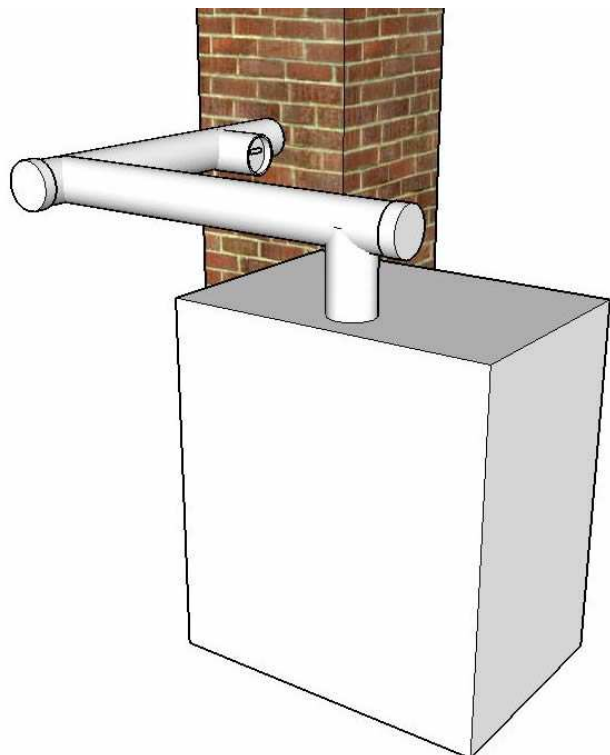

**Example chimney connection**

Particular attention should be paid to the point where a flue passes through a wall or ceiling. The pass-thru should always be made with insulated pipe and the proper accessories or use of a thimble that provides a diameter of not less than three times the diameter of the stovepipe. (See Figure 2)

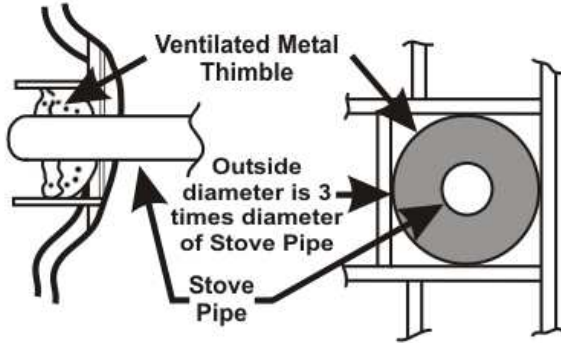

Stove pipe passing through wall

### Wall Pass-Through: United States

In the U.S., the national code is NFPA 211. While many localities adopt this standard, be sure to check with local authorities before beginning your installation. The NFPA (National Fire Protection Association) permits four methods for passing through a combustible wall. A commonly used method to pass through a wall directly to a masonry chimney is to clear a minimum 12" (300 mm) around the entire chimney connector, and fill it with brick masonry which is at least 3.5" (90 mm) thick. A fireclay liner, minimum 3/8" (9 mm) wall thickness must run through the brick wall to the chimney liner (but not beyond the inner surface of the liner). It must be cemented in place with refractory cement.

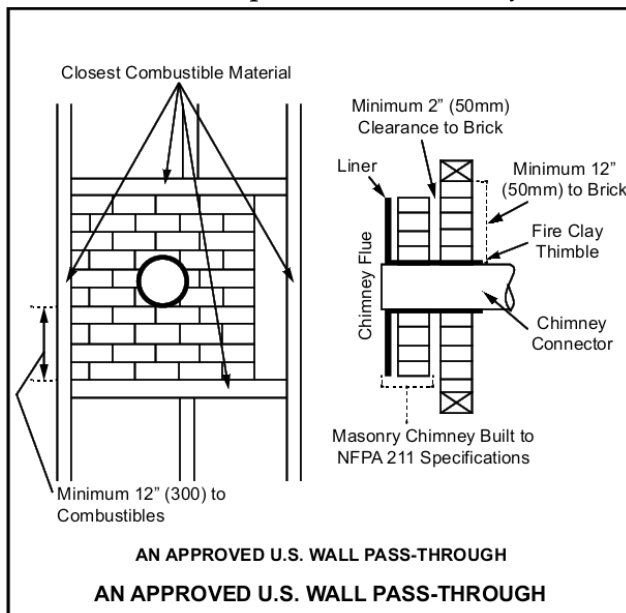

AN APPROVED U.S. WALL PASS-THROUGH

AN APPROVED U.S. WALL PASS-THROUGH

This method is illustrated. For details on the other three options, refer to the most recent edition of the NFPA 211 code.

### U.S. Wall Pass-Through

### Wall Pass-Through: Canada

Three methods are approved by the Canadian Standards Association. The diagram following this paragraph shows one method requiring an 18" (450mm) air space between the connector and the wall. It allows use of one or two covers as described in the diagram. The two other methods are described in detail in the current issue of CAN/CSA B365, the national standard.

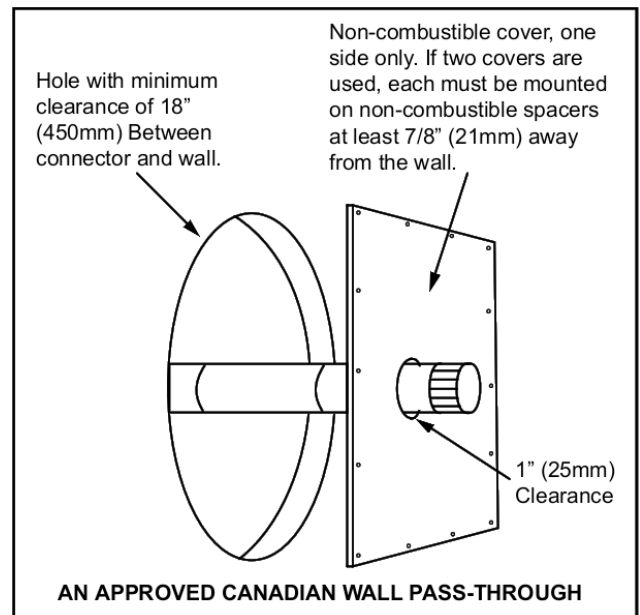

AN APPROVED CANADIAN WALL PASS-THROUGH

Canadian Wall Pass-Through

### CHIMNEY REQUIREMENTS

This unit must be installed into a chimney approved for use with solid-fuel appliances. In the U.S., it must be connected to (1) a prefabricated chimney complying with the requirements for Type HT chimneys in the Standard for Chimneys, Factory-Built, Residential Type and Building Heating Appliances, UL 103, or (2) a code-approved masonry chimney with a flue liner.

In Canada, this unit is listed for use with prefabricated chimneys tested and listed to the high

temperature (650 degrees C) chimney standard, ULC S-629, or with a code approved masonry chimney.

## **Masonry Chimneys**

If you plan on using a preexisting masonry chimney, have it thoroughly inspected and cleaned. Any faults which make the chimney unsafe and unusable must be repaired prior to use. These can include improper height, structural defects, blockages, inadequate clearance to combustibles, unsealed openings into other rooms of the house, signs of creosote or smoke leakage, a loose or absent clean-out door, or absence of a liner.

When connecting to a masonry chimney, several provisions are standard. First, whether the chimney connector is vented to the chimney through a thimble or a breech pipe, neither must pass beyond the inner surface of the chimney liner, and both must be firmly cemented in place with refractory cement. (A thimble is a masonry pipe which is inserted through the chimney wall, and is frequently the preferred method; a breech pipe is a piece of steel pipe used the same way.) In Canada, a breech pipe has ridges or protrusions to lock it firmly into the refractory cement. In either case, the chimney connector vents to the chimney through the thimble or breech pipe.

## **Prefabricated Chimneys**

When venting your Coal Gun boiler using a prefabricated chimney, be sure to contact local building code authorities, and to follow the manufacturer's instructions exactly. Use only the manufacturer's parts; do not use makeshift installation techniques. All prefabricated chimneys must be tested to either the U.S. or Canadian high-temperature standards, UL 103 or ULC-629.

Your manufactured chimney may contain more parts than is shown in the subsequent diagrams. Include all required items in your installation. A chimney cap (A) serves to keep rain and snow from entering the chimney. An approved Class A chimney (B) is required for the Coal Gun Stoker boiler. Wall Bands (C) must be deployed for support per

manufacturer's recommendations. A manufacturer's Wall Support Kit (D) will contain required items for supporting the chimney. Such kits will cost less than individual items purchased separately. A Bottom Cap (E, location marked, but actual cap not shown) allows for cleaning. A Finishing Collar (F) provides inside wall protection. A Wall Thimble (G) provides for required clearance between the chimney pipe passing through a flammable wall. The Chimney Connector (H) must be approved single wall, or a low clearance pipe, installed with required clearances in place. A Roof Brace

(I) is required for chimneys that extend more than a certain distance, as referenced by the



## Inside Chimney

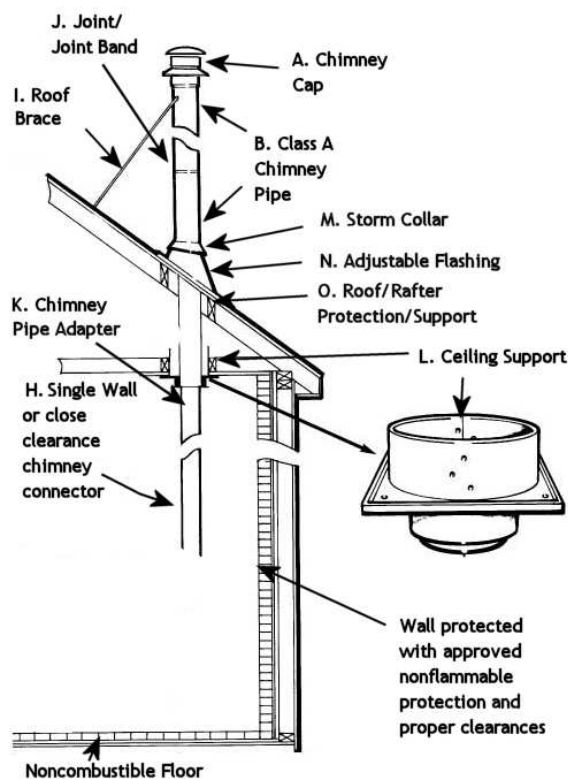

## Outside Chimney

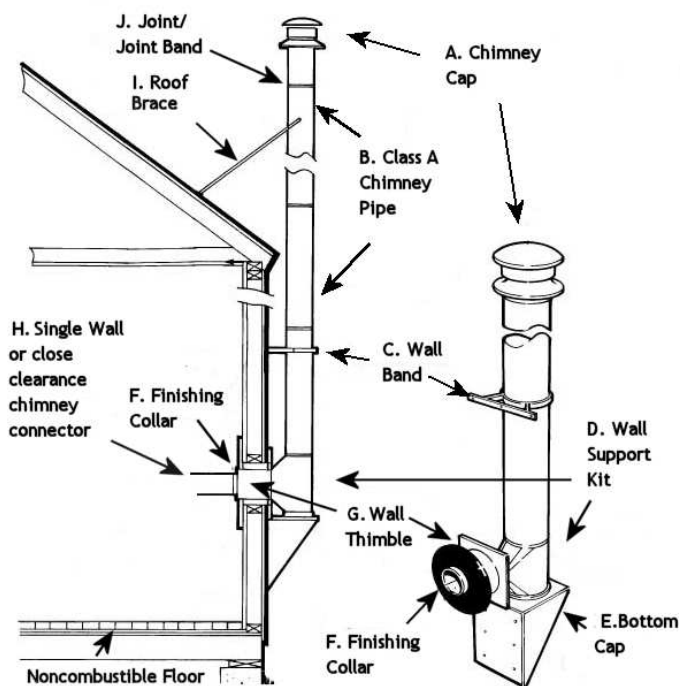

manufacturer's instructions, from the roof. Manufactured chimneys may feature a built in "twist lock" at each joint, but a Joint Band (J) is still normally required to secure pipe at the joint. An

approved Chimney Pipe Adapter (K) is required. A Ceiling Support (L) will provide structural support for the chimney and is typically part of a kit that includes items that maintain required clearances to flammables. A Storm Collar (M), and Adjustable Flashing (N) prevent water from entering the home by running down the outside of the chimney. Additional items or a kit (O) provide additional mounting support or fire protection to the roof joists or other roof components.

## IN CASE OF CHIMNEY FIRE

1. Call the fire department. (In the event the fire is out before they get there, you will want them to inspect the structure and make sure there is no latent damage or hazard.)
2. Shut the boiler down by turning the main power off.
3. If you have a chimney fire, use a chemical flare type fire extinguisher. If you don't have an extinguisher, go to step 4.

4. Using a water hose, wet down the area of the roof surrounding the chimney. Do not wet the chimney itself or try to put water down the flue as it will very likely damage the flue tiles.

5. Contact a chimney professional to inspect your chimney for damages.

## IN CASE OF RUNAWAY FIRE

1. Shut the boiler down by disconnecting power.
2. Be sure the draft inducer is off and/or make sure the barometric damper opens. (Excessive draft can cause a runaway fire.)
3. Maintain continued circulation of boiler water to remove heat from the boiler and if boiler is equipped with a domestic coil run hot water.

## COMBUSTION AIR SUPPLY

It is important to make provision for adequate supply of combustion air, either via natural infiltration through a door or window or by ducting

outside to the boiler. If combustion air is ducted from the outside, then install a metal vent pipe of sufficient diameter for the boiler to be used. Contact Alternate Heating Systems if an outside air ducting kit is required.

When the intake is ducted outside, inspect the opening regularly to be sure that it does not become obstructed by debris.

Outside combustion air may be necessary if:

- The solid-fuel-fired appliance does not draw steadily, produces odd odors, experiences smoke roll-out, burns poorly, or back-drafts, whether or not there is combustion present.
- Any of the above symptoms are alleviated by opening a window slightly on a calm day.
- The house is equipped with a well-sealed vapor barrier and tight fitting windows and/or has any powered devices that exhaust house air.
- There is excessive condensation on windows in the winter.

---

## BOILER PIPING FOR HYDRONIC SYSTEMS

---

Normal operating temperature for the Coal Gun is 180° F. This allows for optimum operation and less fly ash accumulation on heat exchange surfaces. Water returning to the boiler from zones should be about 160° F. After initial startup, return water temperatures should generally be greater than 140° F. If your system design results in water returning to the boiler too cold, incorporate a mixing valve to bring water temperatures back up to acceptable temperatures.

**Note: Hydronic and steam distribution and system design are ultimately the responsibility of the customer or installer.**

Due to the design requirements of the various Coal Gun™ models, the tapplings are not always in the same location on each boiler model. Appendix A: Boiler Specification Diagrams provides detailed

information on how each model should be connected. The washout plugs in the bottom of the unit are a requirement of the ASME boiler code and must be closed before filling the unit with water.

**Note: Be sure to close all ports in the unit before filling the unit with water.**

A boiler drain should be inserted in the tapping on the opposite side of the boiler from the tapping used for the return. Optionally, a “T” and short nipple could be attached to the return tapping for the location of the boiler drain.

## Piping the Boiler in Parallel with another Boiler

The Coal Gun™ may be connected to a heating system supplied by one or more boilers that are already in place. There are many possible configurations that allow for an existing boiler to function as a backup to the Coal Gun™. For sample illustrations of multiple boiler configurations, see Appendix I.

A minimum of 1” diameter pipe should be used for this connection on the model S130. In any event, the pipe size must be determined by taking into account the distance involved and flow required.

## Checklist: When the Boiler is Added to an Existing System

- ✓ Operate the (gas, oil, electric) boiler periodically to ensure that it will operate satisfactorily when needed.
- ✓ Do not relocate or bypass any of the safety controls in the original (gas, oil, electric) boiler installation.
- ✓ The operation of the gas boiler must be verified for acceptable operation before and after installation of the add-on appliance by a gas fitter who is recognized by the regulatory authority.
- ✓ Do not connect to any chimney or vent serving a gas appliance.

- ✓ The installation should comply with requirements of CAN/CSA-B365, and changes to the installation should comply with CSA B139 (for oil-fired), C22.1 (for electric), or CAN/CGA-B149.1 or CAN/CGA-B149.2 (for gas-fired).

### Pressure Relief Valve

The pressure relief valve is factory installed into a fitting on top the boiler. A length of copper pipe must be connected to the pressure relief valve, continuing to a point 6" from the floor. Extending the pipe to the floor is a requirement of building codes. It reduces the likelihood that a release of boiler pressure would scald anyone standing near the boiler.

### Pressure Reducing Auto Fill

It is required to provide for a make up water supply using a pressure regulating valve and backflow prevention valve in the feed water line of your primary boiler.

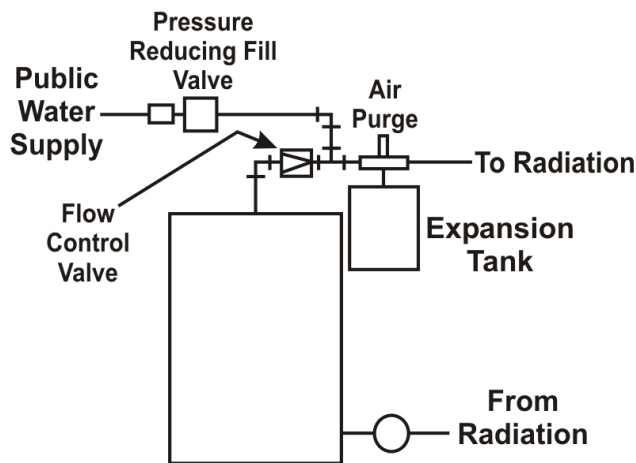

**Pressure regulating valve and backflow prevention valve configuration**

### Expansion Tank

<b>⚠ CAUTION</b>	
	PROVIDE ADEQUATE EXPANSION TANK
It is very important to provide adequate expansion tank capacity based on the total volume of water in the system, particularly when the Coal Gun™ is added to an existing boiler.	

It is very important to provide adequate expansion tank capacity based on the total volume of water in the system. This is particularly true if the Coal Gun™ is added to an existing boiler. Check the chart to determine the water capacity of the Coal Gun™ installed. If you are adding a Coal Gun to your system, most likely the expansion tank or air cushion tank installed originally is not adequate for the additional water volume added to the system with the Coal Gun™.

### Low Water Cutoff

<b>⚠ CAUTION</b>	
	LOW WATER CUT-OFF REQUIREMENT
Some states require that all hydronic heating systems have a low-water cut-off control.	

Many states require that all hydronic heating systems have a low-water cut-off control. Even if your state and local codes don't require this, it is still highly recommended. In cases where this control is required it should be located in a "T" placed in the supply riser just above the tapping in the boiler.

---

### BOILER CONDITIONER / SEALANT

---

AHS provides two bottles of Boiler Conditioner/Sealant with the purchase of your

boiler. When filling your boiler with water for the first time, mix contents of each bottle with 2 gallons of warm water. Pour into any suitable boiler opening. Replace plug, fill and pressurize the boiler. An MSDS is available upon request.

---

## BOILER PIPING AND CONTROLS FOR STEAM SYSTEMS

---

All Coal Gun™ models are available with steam tapplings and controls by special order. When installing a steam boiler, be sure that the installation conforms to all state and local codes.

All steam boilers will be supplied with a low water cut-off, which fits into a special tapping on the rear of a Coal Gun steam boiler. This control must never be hot wired or disconnected since it prevents the boiler from firing should the water level drop below the safe operating level.

A water level gauge glass is also provided for steam systems to give a visual indicator of the level of water in the boiler. An automatic water feeder (mechanical type) or combination water feeder/low water control such as a McDonnell-Miller model 47-2 is required to ensure that the proper water level is maintained. Some states or cities require two low-water control devices in series. The two controls described above will meet this requirement.

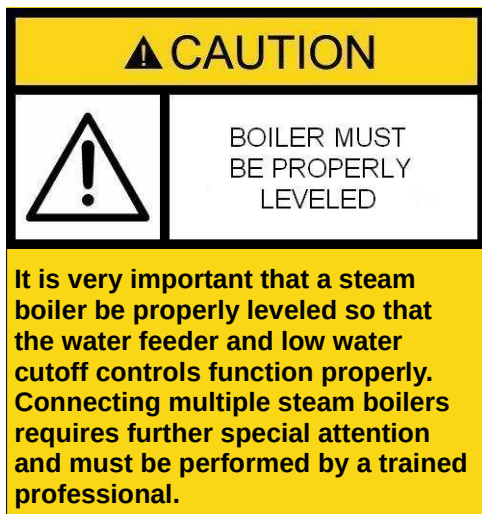

It is critical in steam applications to take into account the BTU rating of the radiators in the

system. If the boiler cannot meet this capacity, there will be areas that do not receive heat.

Steam boilers also have a different wiring sequence, so the proper wiring diagram must be consulted (see Appendix A: Boiler Specification Diagrams).

---

## FORCED HOT AIR SYSTEMS (WATER TO AIR COIL IN DUCT)

---

The Coal Gun™ boiler may be easily adapted to any forced hot air heating system by installing a heat exchange coil in the hot air supply duct. The size and type of coil or heat exchanger required may be established after several factors are determined. These factors include: the heat output required (BTUH), the capacity of the existing fan blower (CFM) and the size of the duct or plenum where the coil will be installed. Sizing of the air coil will be the responsibility of customer and/or installer.

The coil creates increased resistance to air flow, so this factor must be considered when determining the final airflow. Design water temperature is usually 180° F, and a desirable output air temperature is 115° - 125° F. The coil is connected in the same manner as in other types of radiation heating equipment. The thermostat can be wired to engage both the fan blower and the circulator pump.

If a hole was cut in existing ducting to install the coil, the opening should be closed tightly with a metal cover and sealed with duct tape.

---

## DOMESTIC HOT WATER COIL PIPING

---

The Coal Gun™ may be fitted with a domestic hot water coil, which threads into a 4" tapping in the boiler. Multiple coils can be installed into larger boilers, the total number dependent on the size of the boiler and the number of fittings made available at time of manufacture. There are three methods for plumbing the domestic coil. One way is to connect the coil in series with an existing hot water heater.

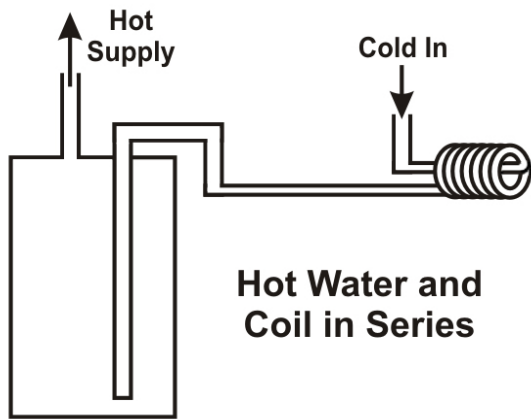

**Hot Water and Coil in Series**

**Plumbing – Coil in Series**

A second method of plumbing the domestic coil is to connect the coil in parallel with an existing water heater so that the conventional water heater may be used when the Coal Gun™ is not being fired (for example in the summer). The diagram that follows indicates how this can be done.

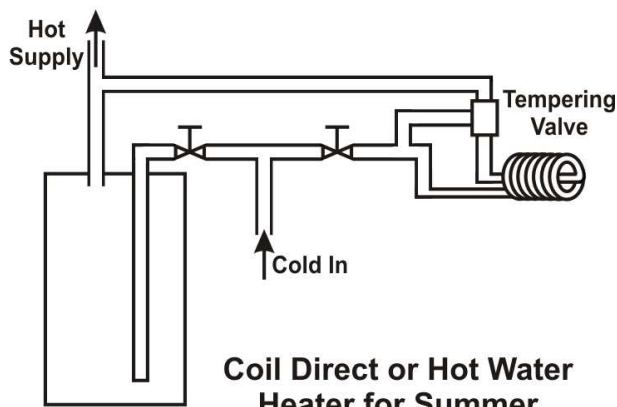

**Coil Direct or Hot Water Heater for Summer**

**Plumbing – Coil in Parallel**

<b>▲ CAUTION</b>	
	SCALD HAZARD
In installations where the coil discharges directly into the hot water distribution system a tempering valve must be included to limit the temperature of the water at the faucet to a safe level.	

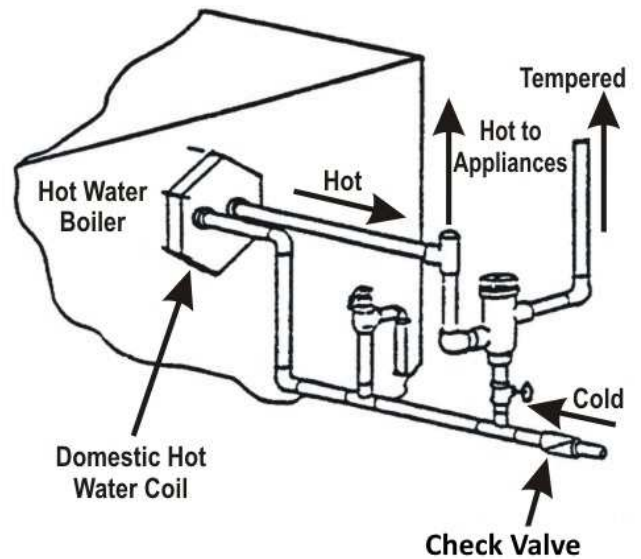

**Tempering valve**

The third method of plumbing the domestic coil uses a small pump to circulate water continuously between the coil and existing hot water heater. It is also necessary to include a tempering valve or temperature controller on the supply side of the storage tank/water heater to prevent super-heated water from reaching the domestic hot water tank and, ultimately, the faucets.

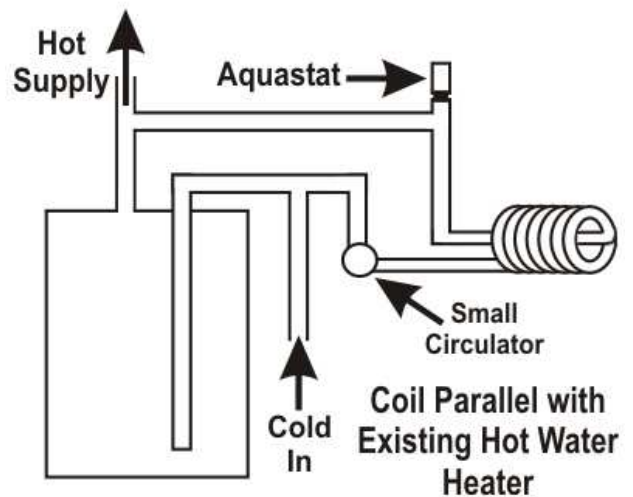

**Coil Parallel with Existing Hot Water Heater**

**Plumbing – Coil with circulator**

**ILLUSTRATED INSTRUCTIONS FOR INSTALLING COAL HOPPER ON S130 AND S260**

Step 1: Disconnect all power to the boiler.

Step 2: Loosen hopper collar screws until they are flush with the inside of the hopper collar.

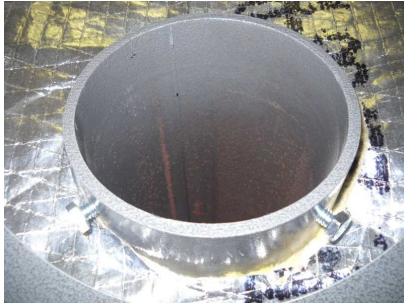

**Coal Inlet Tube: Seen Without Hopper**

Step 3: Insert hopper tube into the hopper collar and tighten screws until snug. Make sure that the hopper is level or adjusted to your preference.



**Hopper Installed**

Step 4: Feed the wires for the hopper temperature sensor into the empty junction box on the side of the hopper. Insert green ground wire into the grounding block and tighten. Attach blue and yellow wires to sensor. It doesn't matter which way these wires are connected.



**Hopper Temperature Safety Switch: Cover Open**

Step 5: Tuck all wiring into the box and replace cover.



**Hopper Temperature Safety Switch: Cover Replaced**

Step 6: Connect/reconnect power.

---

## **ELECTRICAL CONNECTIONS IN THE COAL GUN™**

---

All hydronic Coal Guns are prewired to maintain boiler water temperature at approximately 180° F.

### **S130/S260 Power Requirements**

The S130 and S260 Coal Guns require a dedicated power circuit of 120 volts, 15 ampere.

### **Power Connections**

Power connections are made inside the large enclosure for the controls. A photo of the area where connections are made follows.

1. Before making connections, use a multimeter to verify correct wiring and voltage on your wiring circuit providing power to the Coal Gun.
2. Turn off circuit breaker or otherwise disconnect power to the circuit.
3. Attach your neutral conductor to any terminal labeled "N".
4. Attach your line providing power to the terminal labeled "L1".
5. Attach your ground conductor to the green terminal.

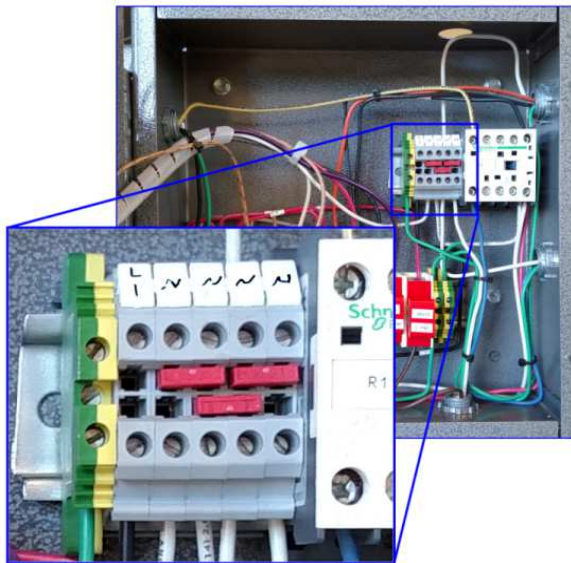

**Terminal Detail for Power Connections**

---

## CONTROLS

---

### Aquastat Controls

Coal Guns for hydronic heating have no provision for control wiring connections to building thermostats. As stated previously, the boilers are designed and wired to maintain water temperature. The control scheme for Coal Gun boilers requires that building thermostats control distribution of the hot water, usually by circulator pumps, zone valves, or both. Hydronic Coal Guns are supplied with dual aquastats. The R-W terminals on the dual aquastat are intended to be used to control a circulator for high water temperature over-ride situations, sometimes known as a “dump zone.” If these terminals are used to directly power a zone, the maximum current draw is 3 amps.

**Note: it is required that a dump zone be utilized to protect from over heat circumstances. An additional section, dedicated to dump zones, is included later in this manual.**

The Coal Gun is provided with a high limit control, a combination operating limit control, which activates the draft fan, a dump zone control, and an electronic ash temperature monitoring control. It is very important to follow the guidelines listed here for proper operation of the boiler.

The operating limit is designed to maintain boiler temperature under normal operating conditions by turning the draft fan on and off. The range for this control is from 150° F to 180° F. The normal factory setting is 180° F.

The dump zone temperature control is designed to operate one or more heat zones to prevent high boiler temperatures from occurring during low load conditions. This setting should be set 20° F above the operating limit setting with a maximum setting of 200° F. Also refer to the dump zone wiring instructions for specific use applications. See Appendix H for example dump zone wiring applications.

### Mode Switch & Ash Removal

The Mode Switch offers two modes for ash removal, in addition to an OFF position. In **Mode 1** the controller may cycle the grates while the boiler fan operates or not. In **Mode 2** the controller will only operate when the draft fan is running. This control also reduces the likelihood of unburned coal being dumped into the ash pan. Ash removal takes place when the ash temperature has dropped sufficiently to allow the grate motor to cycle. The ash temperature monitoring control incorporates a digital process controller for operating the coal grate motor based on ash temperature in the grate area. maintains active monitoring of grate temperature.

### Thermal Ash Monitor Settings

The Thermal Ash Monitoring Control is factory set to 130° F. Refer to Appendix G for instructions regarding how to adjust the control. When reading the digital readout, PV refers to the process variable, or actual ash temperature reading. SV refers to the set point variable, or the temperature set point of the control, which is the reference point for governing the grate operation. Another important setting on the control is referred to as hysteresis. This value represents the offset in degrees between the set point variable (SV) and grate operation. The factory setting for hysteresis is 1° F. Based on factory settings, when the temperature of the ash drops to 1° F below the

reading indicated at SV, there will be a call for the grates to cycle on, operating until ash temperature climbs to the SV value. Whether the grates will be actually observed to be running at this time will depend on the position of the Mode Switch, whether the induction fan is running, and where the timers are at in their cycle. The Mode Switch and Grate Timers are described a bit later.

The setting of the Thermal Ash Monitoring Control is the preferred way to keep the height of the fire set correctly in the Coal Gun. The lower your set point (SV), the higher the position of the fire will be in the burn pot. This is because the fire must necessarily be further from the thermocouple based sensor in order to reach the lower ash temperature on the monitor. The optimum setting is the one that gives you the best balance of efficiency and performance. A Coal Gun under moderate demand that has been actively firing for 10 minutes or more should have a relatively small cone of black coal in the center of the burn pot, with vigorously burning coal all around the circumference of the burn pot surrounding it. The photo below illustrates acceptable fire positioning.



**Coal Gun Fire Position**

In addition to a higher position for the fire, a lower setting on the Thermal Ash Monitoring Control will also mean deeper ash under the fire and more opportunity for coal to burn completely before dropping into the ash tub. There will also be less likelihood that you will experience coal gas building up and lighting off suddenly in the boiler. The main downside is greater likelihood that the fire will go out during an extended period of low demand. Deeper ash can also mean lower peak airflow and therefore, typically lower peak output. When you have high demand, raising the setting can increase peak output, but may also lead to some unburned coal dropping into the ash pan. If you have adjusted this control and it is already set 10° F or more above or below the factory settings, limit adjustments to a maximum of 5° at a time, and let the boiler operate at the new setting for 48 hours before observation and readjustment. The most important observations are the position of the fire in the burn pot and ash quality. For the latter, you want to see less unburned coal. Keep in mind that coal quality will play a role in obtaining good ash quality.

## Grate Timers and Settings

The grate interval timers consist of two Schneider timers located inside the control box. These allow fine tuning of grate motor run time. There is both an “On” timer and an “Off” timer. The On timer limits the maximum run time. The Off timer enforces a minimum off cycle. The interval timers engage when the Thermal Ash Monitoring Control is calling for grate operation.



**Grate Timers**

Keep in mind that most Coal Gun boilers will not require adjustment of the internal, grate interval



timers. Your boiler's factory settings on the internal timers are already quite adequate for most situations. Rarely, it may be necessary to adjust the timer to adapt the boiler to conditions like unusually low or high demand or poor quality coal. Even under such circumstances, adjusting the temperature setting on the grate control, easily accessed on the front panel of the control box, is normally sufficient. The following instructions should only be consulted if adjusting the Thermal Ash Monitoring Control is insufficient to getting good results.

The On timer and the Off timer consist of a white dial and a black knob (see photo above). The white dial on the timer allows you to select the scale in seconds, minutes, and hours. The black knob selects the duration or a percentage of the scale selected by the white dial. For example if the white dial is set to the scale 1-10min and the black knob is set at 5 then it will time out around five minutes. A stop watch must be used to be sure that the change is made accurately. The **off** timer should always be set equal to or higher than the **on** timer. Usually setting the off timer 20 to 30 seconds longer than the on timer is appropriate.

If the timers were adjusted incorrectly and need to be reset, use these parameters:

The **factory setting** for the **On timer** is as follows: The white dial is set at 6-60sec and the black knob is set at 4 ½.

The **factory setting** for the **Off timer** is as follows: The white dial is set at 1-10min and the black dial is set at 3.

When adjusting the timer cycles, be sure that you are able to observe the boiler's operation every hour or two for eight hours. Be sure to limit each adjustment to a change of no more than 30 seconds per grate operation cycle. All adjustments must be checked with a stop watch to ensure correct timing. Always allow 48 hours for the boiler to acclimate to the adjustment made previously before making another 30 second adjustment. CAUTION if the timer is adjusted to keep the grate motor off too long, it will cause the fire to travel towards the

hopper, triggering the heat sensor, which will turn off the boiler. The same can happen if the grate switch is left off too long.

In circumstances that include high demand, the boiler may be able to produce more heat through a modest timer adjustment. Increase the **on timer** value by turning up the white dial to 1-10min. and set the black dial to 2. Allow 48 hours for the boiler to acclimate to the change. If more adjustment is needed increase the black knob on both the **on** and **off timers** thirty seconds each. Repeat these steps as needed but do not exceed setting the on timer higher than 9 ½ and the off timer at 10. As always make sure the off timer is set longer than the on timer by at least 30 seconds.

If the coal ash has a high percentage of unburned coal reducing the run time of the grate may help. It is not advisable to make adjustments unless the problem is persistent. To adjust the run time of the grate, turn down the set value of the **on timer** 30 seconds with the black knob. Allow the boiler to acclimate for 48 hours. If the coal ash still contains a large percentage of unburned coal after 48 hours, turn down the set value of the **on timer** 30 seconds with the black knob. When demand on the boiler increases inspect the boiler twice daily to ensure the grate is removing enough ash to allow the boiler to keep up with demand and to also make sure that the fire is not burning into the hopper.

Never make adjustments to the grate interval timer that would inhibit the grate motor from running less than 30 seconds every 10 minutes.

The power switches are located on the front of the control panel. The "Main" switch will shut off all power to the unit. The "Grate" switch will shut down the grate motor function.



## Thermostat Connection

Hydronic Coal Guns do not require a connection to a building thermostat for operational purposes. The boiler water temperature is controlled by the aquastats.

---

### STEAM

---

Steam Coal Guns require a connection to a building thermostat. The switching relay on the Steam Coal Gun has two T terminals to which a low voltage thermostat must be connected.

---

### BOILER DUMP ZONE APPLICATIONS

---

Unlike oil or gas fired boilers, solid fuel boilers will still produce some additional heat after the call for heat has ended. This will cause the boiler temperature to rise if no zones are calling for heat. It is possible to see temperature rise 30° F or more under a low or no load condition. This will take place until the boiler's radiation losses match the heat gain. It is recommended that a dump zone be connected to dissipate this excess heat to one or more zones in the system. Setting the operating limit no higher than 180° F allows for the heat rise to occur without exceeding the recommended maximum temperatures.

The dump zone aquastat can be used to activate a zone valve or circulator as a dry contact switch. A common setting for dump zone actuation would be 210° F, with the high limit set point adjusted to 10° - 20° lower. When this high limit is exceeded, and temperature reaches the dump zone limit, one or more zones will be energized and heat distributed

until temperatures fall sufficiently. See Appendix H for a variety of dump zone wiring examples.

If the dump zone is connected to provide heat to a domestic hot water tank or heat exchanger, a mixing valve must be installed on the potable system supply to prevent an unsafe condition of overheating the domestic hot water. The mixing valve outlet should be set no higher than 125° F for potable use (for this type of dump zone, see Appendix H, Example 5).

## Non Powered Dump Zone

A non powered dump zone is required in some localities. It is also required for applications utilizing the UL Listed Coal Gun, and anywhere backup power is not immediately available to a powered dump zone. A non powered dump zone provides a way to dump boiler heat in the event that an over heat situation occurs, such as may occur during a power failure. This hot-water circulation loop shall be able to dissipate at least 10% of the estimated rated heat output of the solid-fuel boiler when circulation is reduced because of an electrical power failure. The loop can only be made inoperative by a deliberate manual action. The design parameters for sizing shall be a pipe size equal to or greater than 3/4 inch (18 mm), room temperature of 65°F (18°C), and mean water temperature of 180°F (82°C).

The loop shall be positioned above the boiler, with features that promote natural thermal circulation of the water. The piping must be such that excessive pressure will not develop in any portion of the boiler or system. Larger diameters may be needed as boiler size increases. Figure 9 shows an application example of how this is accomplished.

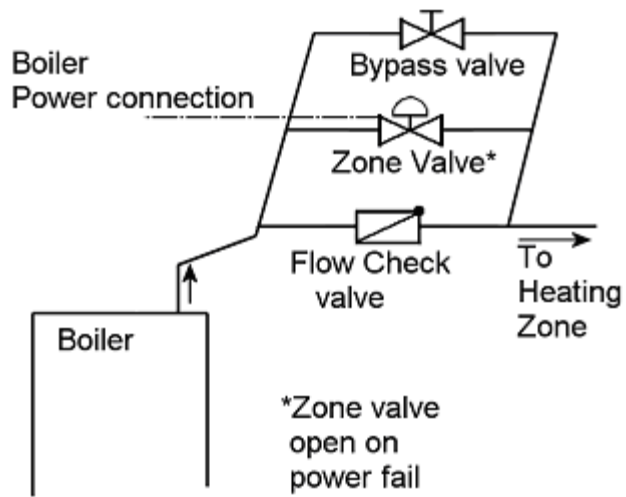



Figure 9: Non-Powered Dump Zone

This arrangement will allow a gravity flow of heat release in the event of a power failure. For other dump zone applications, see Appendix H.

# Operating Information

Please read this manual before operating the boiler. Important requirements and instructions must be followed for safety and satisfactory operation of the boiler. When operating the unit you must keep the doors closed and maintain the seals in good condition. All covers or guards must be in place at all times, except for maintenance or service.

The quality and burning characteristics of coal vary widely so it is important to use the type of coal for which the Coal Gun™ was designed. Best results will be obtained using pea-size anthracite having a high ash fusion temperature. No bituminous or lignite types of coal are acceptable for use in the Coal Gun.

<b>⚠ WARNING</b>	
	PRESSURIZE AND FILL BOILER VESSEL BEFORE STARTING FIRE
Be sure the boiler vessel is full of water and pressurized before starting a fire. Never attempt to add water to a hot boiler if found to be only partially full. Allow the unit to cool before adding water to the boiler. Failure to do so could result in death or severe injury along with damage to boiler and surrounding property.	

---

## LIGHTING THE COAL GUN™

---

<b>⚠ DANGER</b>	
	NEVER USE FLAMMABLE LIQUIDS TO START FIRE
Never use chemicals or flammable liquids to start the fire. DO NOT burn garbage, other types of coal or any other fuel not approved for this unit.	

When starting a fire, it is advantageous for both the system and the house to be cold. This allows the Coal Gun to establish a good burn before reaching maximum temperature, after which the draft induction fan that powers combustion will shut down. Before starting the fire, turn off the grate switch and fill the hopper full of pea or buckwheat coal.

At this point, when you look into the coal pot through the sight hole cover, you will see coal lying close to the opening. Insert several fire starters (such as Rutland Safe Lite, Easy Light Charcoal or Match Light Charcoal) so that they are nearly covered by the coal. Turn on the Coal Gun boiler switch. The induction fan will be running at this time. Light the starters with a match, wand type lighter or propane torch. A propane torch works best for quick lighting. When the starter material is fully inflamed, let the sight tube flap drop over the tube. The sight tube flap should be pulled snugly inward against the sight tube (see Operation of Sight Hole Cover below). Allow the Coal Gun to run for one to two hours in order to allow the coal in the coal pot to burn, and for the fire to become well established. Once the ash temperature has climbed to over 155 degrees or higher, turn the grate on. The first time the grates cycle, there will be a bit of unburned coal in the ash tub. The S130 and S260 Coal Gun™ are furnished with a single ash tub. An extra tub can be obtained from Alternate Heating Systems.

<p>The use of emergency power from a backup generator is necessary for operating the Coal Gun™ during a power failure. Without backup power, the fire in the Coal Gun will gradually go out. The boiler will be unable to supply heat without backup power.</p>
---

### Warning- Risk of fire:

- Do not operate with fuel hopper lid off or ash removal doors open.

- Do not store fuel or other combustible material within marked installation clearances.
- Inspect and clean flues and chimney regular.

### Caution

- Unit is HOT while in operation.
- Do not touch during operation.
- Do not operate without the hopper lid, sight tube cover, or ash pan and ash doors in place.
- Boiler will have multiple hot surfaces.
- Keep children away.

### OPERATION OF SIGHT HOLE FLAP

The proper operation of the sight tube flap is crucial both in the off cycle and during fan operation. The flap position during the off cycle must be open allowing a gap of 3/8” or more between it and cover seat. This allows air to bypass the fire bed, preventing over heating of unit during the off cycle.

The sight tube flap is located behind the sight tube cover. To ensure safety it is imperative that the sight tube cover be in place during operation.



Sight Tube Cover in Place

Sight Tube Cover Removed

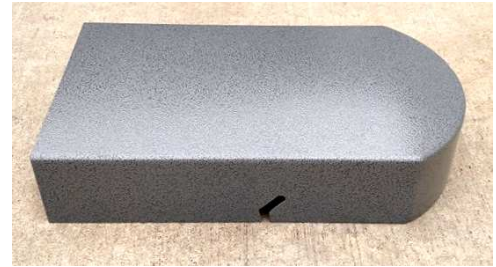

<b>⚠ WARNING</b>	
	KEEP SIGHT TUBE COVER IN PLACE AT ALL TIMES
<b>Except for boiler lighting, maintenance or inspection, the sight tube cover is not to be removed.</b>	



Sight Tube Flap in Open Position (Sight tube cover removed)



Sight Tube Flap in Closed Position

**Note: In the photos above, the sight tube is displayed with the cover removed for inspection purposes.**

When the fan is running and boiler is full of coal, the sight tube flap must be drawn against the cover

seat automatically and held there during the time the fan runs. This is necessary to force combustion air through the fire bed rather than across the top.



Chimney draft conditions and fuel conditions both affect the balance necessary to achieve the sight tube flap function. Adjustment of the nut and spring tension holding the sight tube flap is sometimes necessary after installation. When this adjustment has been made, be sure to reattach the cover over the site tube.

---

### SHUTTING DOWN THE COAL GUN

---

When the heating season has ended, or in anticipation of a long period with no demand for heat, it will be desirable to allow the fire to go out in the Coal Gun™. Unlike non-solid fuel boilers, the fire in the Coal Gun will not go out instantly. It will necessarily have to coast to a stop.

The procedure for shutdown is to turn off the boiler "Main" switch and to simply wait until the fire goes out. It will be important during this time to maintain the sight tube cover in the open position, as seen in Figure 10. Without power to the draft-inducing fan, the boiler cannot actively fire and will over a period of days lose the fire. When the fire has gone out and the boiler has cooled sufficiently, the cleanout procedure described in Appendix D may be performed. This procedure is generally conducted at the end of each heating season.

When shutting down the boiler to clean the unit, simply stop adding coal to the hopper. Allow the remainder of the coal to burn out before turning off

the main switch. Keep in mind the boiler draft motor will continue to run after the coal is used up until the main switch is turned off.

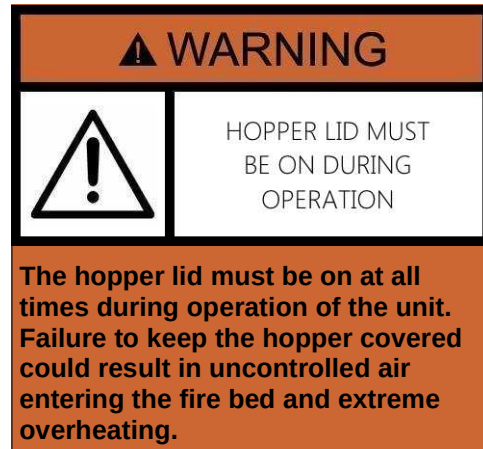

---

### AUTOMATIC FUEL DELIVERY SYSTEMS

---

The Coal Gun has two methods of fuel delivery; a hopper, or an auger and hopper combination. When the hopper alone is used, the Coal Gun can run unattended for up to seven days. When used alone, the hopper must be filled by hand with a scoop or bucket. After the hopper is filled the lid MUST be placed on the hopper for combustion to occur properly. Coal is then fed by gravity from the hopper into the burn chamber.

If an auger is used to feed coal, the hopper and lid are still also used except the lid is designed with a hole to allow the coal to fall from the auger through the lid and into the hopper. The auger must be equipped with a snout, and the snout of the auger must be securely attached to the sealed hopper lid. The lid must be oriented on the hopper so that the coal falls from the auger snout into the hopper within 10 inches of the sensor, as seen in the Auger Drop Location diagram at the end of this section.

### Basic Auger Operation

These instructions apply only to Coal Gun™ systems supplied with auger feed:

The automatic auger switch has 3 positions:

- Off – disables auger function (middle position)
- Manual – This position energizes the auger at all times (for maintenance only)
- Automatic – Use this position to operate the auger in automatic feed mode. The auger will be controlled by the hopper level sensor and will maintain the level of coal in the hopper.

The level sensor responds to the proximity of coal. As the hopper empties, coal will fall away from the sensor. After a programmed delay, normally one minute, the sensor will turn on the auger. The sensor will turn off the auger once a sufficient amount of coal makes contact with it.

Auger must be set up to drop coal as close to the sensor as the lid will allow. (10")

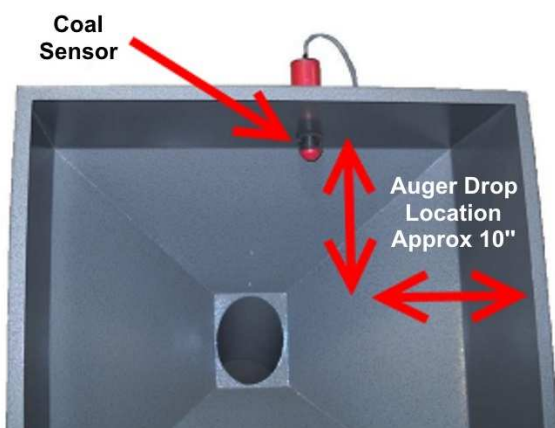

**Auger Drop Location**

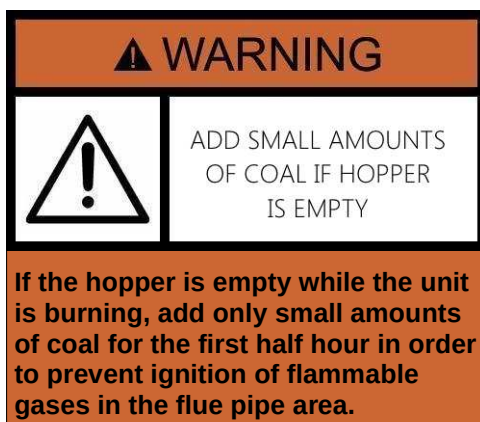

### Auger assembly

The auger should be mounted to and connected to the hopper lid. It must also be supported by

suspension from the ceiling or overhead structural framing so that the weight of the auger does not rest on the hopper lid.

---

## THERMO ASH-MONITORING GRATE CONTROL OPERATION

---

Ash that contains fuel that is not fully combusted will be a higher temperature than ash coming from thoroughly combusted fuel. The Thermo Ash-Monitoring Control automatically monitors the temperature of the ash leaving the coal pot. This provides a feedback mechanism for grate regulation that reduces the need for post install adjustments. Typically, no adjustment other than the factory adjustment is necessary to have the boiler perform at peak output throughout the burn season. Minor on-site adjustments may be necessary when the boiler is first installed to provide for a more complete burn (less unburnt coal) or to optimize position of the fire. See the section in the Installation portion of the manual for more information. With the Thermo Ash Monitoring controlled grate, it is possible for the fire to remain lit for days during low usage periods without having to adjust the grate controls.

The ash temperature sensor is set at the factory at 130° F, for normal operation. During periods of light demand, reducing the setting to 120° or lower may aid in maintaining the proper level of coal in the coal pot. For more information see “Controls” section.

---

## FUEL STORAGE / REMOVAL AND DISPOSAL OF ASHES

---

Fuel shall not be stored within the appliance installation clearances or within the space required for refueling, ash removal, and other routine maintenance operations. Store fuel in a purpose built storage unit that is adequate for the volume of fuel that you will be handling. The storage unit should keep the fuel dry and should be accessible to clean when empty.

**Note: Burn Pea Or Buckwheat Size Anthracite Coal Only!**

Ashes should be placed in a metal container with a tight fitting lid. The closed container of ashes should be placed on a non-combustible floor or on the ground well away from all combustible materials pending final disposal. If the ashes are disposed of by burial in soil or otherwise locally dispersed, they should be retained in a closed container until all cinders have thoroughly cooled to prevent inadvertently starting a fire.

---

## **TREATMENT OF BOILER WATER**

---

Proper treatment of make-up water and boiler water are necessary to prevent scale or other deposits and corrosion within the boiler. The absence of adequate external and internal treatments can lead to operation upsets or total boiler failure. Where a choice is available, pretreatment external to the boiler is always preferred and more reliable than treatment within the boiler.

Instructions for feed water treatment as prepared by a competent feed water chemist should be followed. Do not experiment with homemade treatment methods or compounds.

Representative samples of feed water and boiler water need to be analyzed frequently to ensure that they are in specification. The following terms and guidelines are to be used in conjunction with the advice of a water treatment specialist.

### **Ph**

The Ph value of your boiler water is a number between zero and fourteen. Values below seven are acidic while values above seven are basic.

The Ph factor is the most important factor influencing scale forming or the corrosive tendencies of boiler water. It should be adjusted to between a minimum of 10.5 and a maximum of 11.0 to prevent acidic corrosion of boiler tubes and plates and to provide for the precipitation of scale forming salts.

Below a Ph of 5.0 the water is acidic enough to dissolve the steel boiler plates. Under these conditions the steel gradually becomes thinner and thinner until it is destroyed. At a Ph between 5 and 9.4 pitting of steel plates will occur at a rate dependent upon the amount of dissolved oxygen in the boiler.

### **Dissolved Oxygen**

Aeration of city water supply is frequently used to remove other noxious gasses, however, efficient aeration results in saturation of the water with oxygen. The majority of corrosion problems are directly related to the quantity of dissolved oxygen in the boiler water. Elimination of the corrosive effect of dissolved oxygen can be accomplished either directly or chemically.

Direct or mechanical removal of dissolved oxygen is done through the use of a de-aerator. Chemical de-aeration is done through the introduction of specific chemicals in the boiler to react with the oxygen. The dissolved oxygen content should not exceed 0.007 mg/l.

### **Sulfites**

Sodium sulfite is generally used for the chemical removal of dissolved oxygen within the boiler water. To assure the rapid and complete removal of the oxygen entering the boiler feed water system the concentration of sulfite in the boiler must be maintained at a minimum of 120 ppm. (parts per million).

### **Solids**

Solids can be broken up into two categories; suspended and dissolved. Suspended solids are those that can be removed by filtration while dissolved solids are in solution with the water.

The best test for the determination of the solids content of the boiler water is through a conductance test. The conductance value of boiler water varies by the various ionized salts present. The conductance can be used to measure the total dissolved solids in the boiler water and to serve as an accurate means



for the control of solids through the use of blow down.

Another test that is sometimes used as a measure of solids is to measure the chloride present in the boiler water. The ratio of chlorides in the boiler water to that of the feed water can be used as a means to determine the amount of blow down required. The chloride test is unsuitable for feed water with low incoming concentrations, and the concentrations in the feed water must be averaged over time for accuracy.

High boiler solids will lead to foaming, priming, surging, and carry over. These conditions may only be overcome by proper daily blow down of the boiler.

### **Alkalinity**

The alkalinity of boiler water should be sufficiently high enough to protect shell and plates against acidic corrosion, but not so high as to produce carryover. A minimum value for alkalinity for adequate protection is 200 ppm.

High boiler alkalinity (in excess of 700 ppm) should be avoided. Values higher than this can cause the steel to become brittle.

### **Phosphates**

Phosphates are used to react with calcium hardness in the boiler water. In order for this reaction to take place it is important to maintain a Ph at a minimum value of 9.50. It is desirable to keep the concentration of phosphates in the water to 30-50 ppm to enable the complete reaction of the phosphates with the calcium hardness entering the boiler through the feed water.

### **Hardness**

The hardness of water is caused by calcium and magnesium ions. Water hardness will vary greatly throughout the country depending on the source of the water.

In boilers hard water can cause the formation of scale and sludge or mud. The hardness must be removed in the makeup water to the return system. Total hardness should not exceed 50 ppm.

### **Oils**

Every effort should be made to prevent oils from getting into the boiler water. Oil causes foaming or combines with suspended solids to form a sludge, which can cause the overheating of boiler plates.

If oil does get into the boiler, the boiler should immediately be taken out of service and thoroughly cleaned.

### **Antifreeze**

Antifreeze use is recommended where there is any danger of the boiler water freezing. The Coal Gun vessel warranty does not apply to freeze damage. Use concentrations consistent with antifreeze manufacturer recommendations, but do not use pure antifreeze in your system. Glycol-water mixtures expand more than straight water, and may lead to a requirement for increased expansion tank capacity over that otherwise used for straight water. Antifreeze usage, particularly containing ingredients other than propylene glycol, is often prohibited by homeowners' insurance.

**Note: Low flash points for some antifreeze products create a fire hazard when pure antifreeze is used.**

# Appendix A: Boiler Specification Diagrams

# S130 - S260 COAL GUN SPECIFICATION DIAGRAM

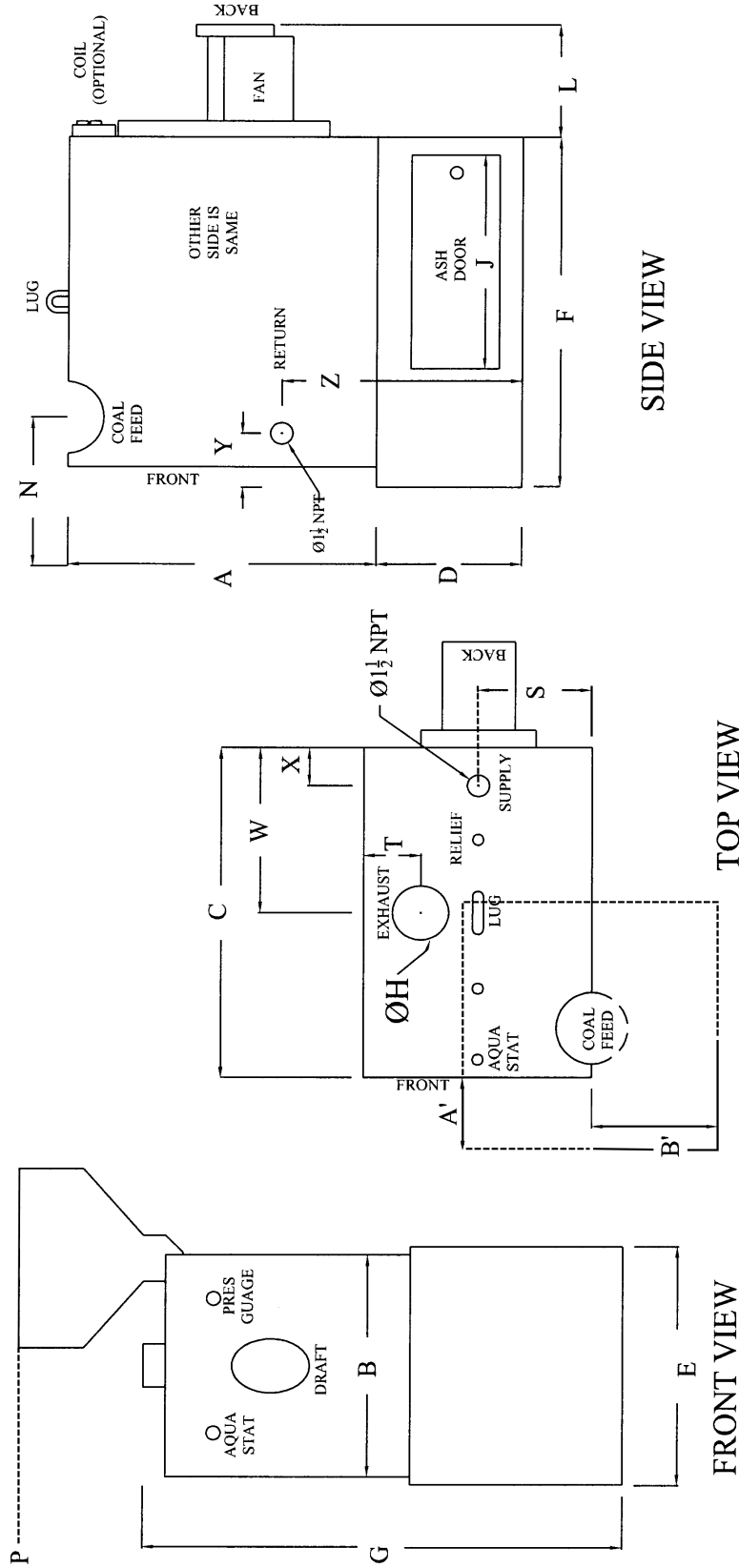

	A	B	C	D	E	F	G	H	J	L	N	O	P	S	T	W	X	Y	Z	A'	B'
	BOILER HEIGHT	BOILER WIDTH	BOILER LENGTH	BASE HEIGHT	BASE WIDTH	BASE LENGTH	TOTAL HEIGHT	FLUE OPENING	ASH DOOR WIDTH	FAN MOTOR LENGTH	COAL FEED	FAN MOTOR HP	TOTAL HEIGHT SM HOPPER	CENTER LINE	EXHAUST LOC	EXHAUST LOC	SUPPLY LOC	RETURN LOC	RETURN HEIGHT	HOPPER OVERHANG	HOPPER OVERHANG
S130	22	21	31	19	24	33	45	5	23	12	10	1/3	58	10	5	15.5	3.5	5	22	4	8.5
S260	26	25	45	21	25	48	50	6	23	19	13	1/2	63	12	6	26.5	4	7	22.5	4	8.5

All dimensions in inches unless otherwise specified. Alternate Heating Systems, Inc. Copyright 2015 Specifications subject to change without notice.

---

## ADDITIONAL SPECIFICATIONS

---

### Pressure Drop

Pressure Drop (Line Loss) within the boiler is less than the pipe rating of the pipe within the boiler, so there is no appreciable pressure drop.

### Explanation of GPM Flow

The following are given as examples of gallons per minute water flow required to deliver hot water

in order to provide heating of a given number of degrees and at a certain BTU level:

- 500K BTU's at 20 degrees temperature differential requires 50 gallons per minute.
- 250K BTU's at 20 degrees temperature differential requires 25 gallons per minute
- 1M BTU's at 20 degrees temperature differential requires 100 gallons per minute

## Appendix B: Wiring Diagrams

# LAVOTA TIMER S130/S260 COAL GUN W/ HYDROLEVEL LWCO and ASH GRATE TEMP CONTROL (UL ONLY)

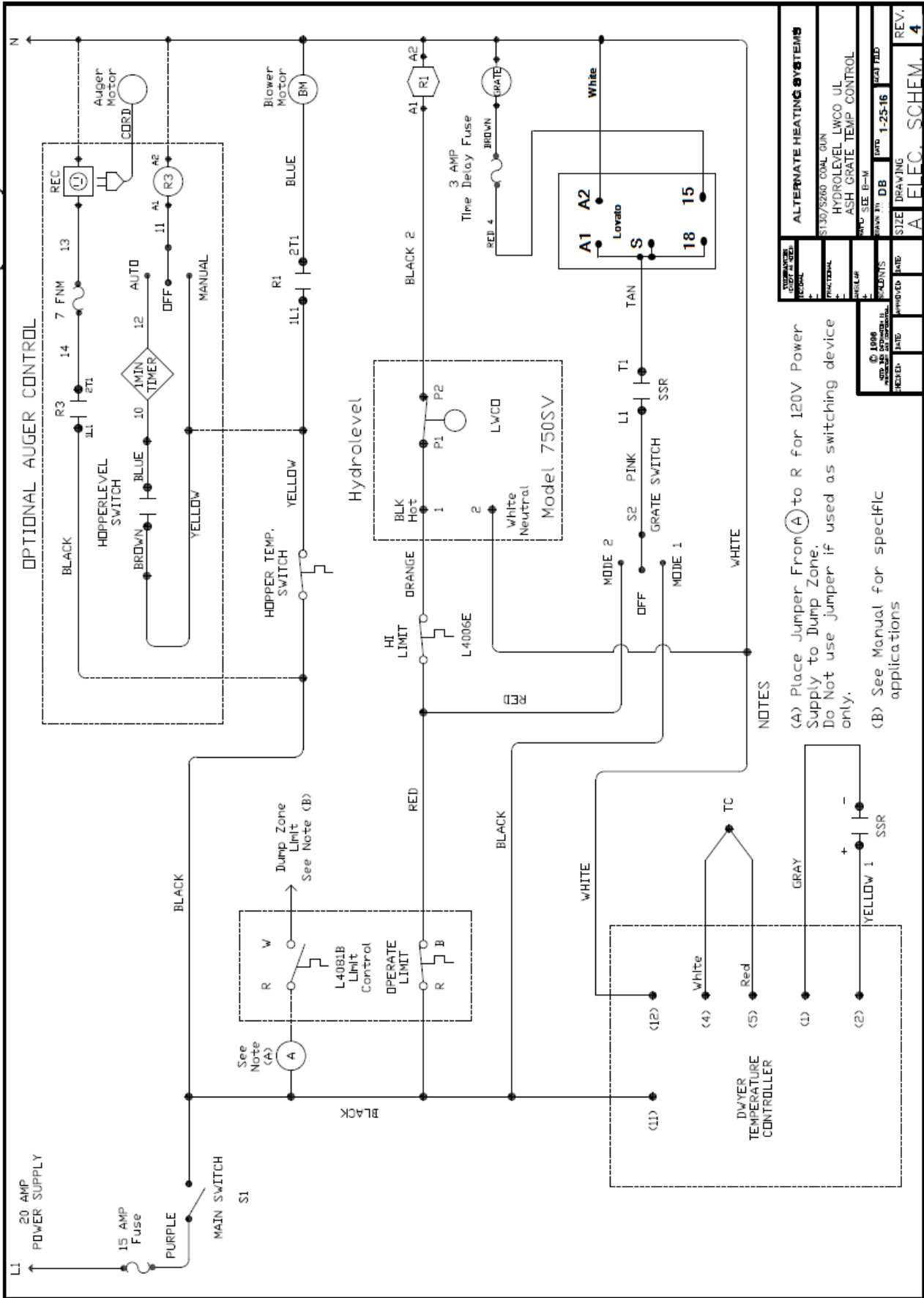

APPROVED FOR CONSTRUCTION	DATE	BY
APPROVED FOR FABRICATION	DATE	BY
APPROVED FOR INSTALLATION	DATE	BY
APPROVED FOR TESTING	DATE	BY
APPROVED FOR DELIVERY	DATE	BY
APPROVED FOR SHIPMENT	DATE	BY

**ALTERNATE HEATING SYSTEMS**

S130/S260 COAL GUN  
HYDROLEVEL LWCO UL  
ASH GRATE TEMP CONTROL

DATE: 1-25-16  
DRAWN: DB  
REV: 4

# SCHNEIDER GRATE TIMER

S130/S260 COAL GUN W/ HYDROLEVEL LWCO and ASH GRATE TEMP CONTROL (UL ONLY)

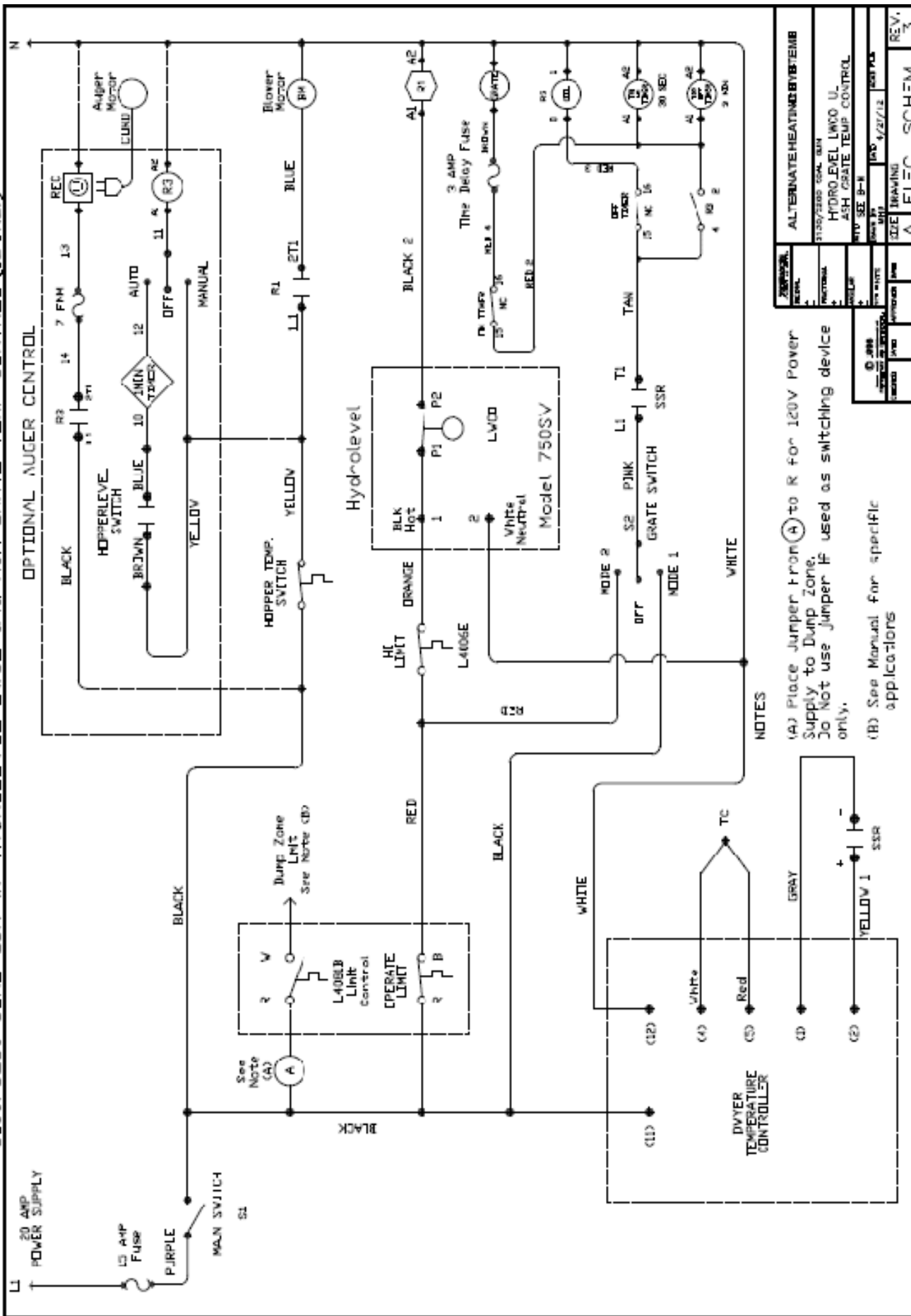

### NOTES

- (A) Place Jumper from (A) to R for 120V Power Supply to Dump Zone. Do Not use Jumper if used as switching device only.
- (B) See Manual for specific applications

REVISION	DATE	BY	APP'D	DESCRIPTION
1	1/22/12	WJ		ALTERNATE HEATING BY SYSTEM
2				S130/S260 COAL GUN
3				HYDROLEVEL LWCO U.
4				ASH GRATE TEMP CONTROL
5				UL SEE B-N
6				UL SEE B-N
7				UL SEE B-N
8				UL SEE B-N
9				UL SEE B-N
10				UL SEE B-N
11				UL SEE B-N
12				UL SEE B-N
13				UL SEE B-N
14				UL SEE B-N
15				UL SEE B-N
16				UL SEE B-N
17				UL SEE B-N
18				UL SEE B-N
19				UL SEE B-N
20				UL SEE B-N
21				UL SEE B-N
22				UL SEE B-N
23				UL SEE B-N
24				UL SEE B-N
25				UL SEE B-N
26				UL SEE B-N
27				UL SEE B-N
28				UL SEE B-N
29				UL SEE B-N
30				UL SEE B-N
31				UL SEE B-N
32				UL SEE B-N
33				UL SEE B-N
34				UL SEE B-N
35				UL SEE B-N
36				UL SEE B-N
37				UL SEE B-N
38				UL SEE B-N
39				UL SEE B-N
40				UL SEE B-N
41				UL SEE B-N
42				UL SEE B-N
43				UL SEE B-N
44				UL SEE B-N
45				UL SEE B-N
46				UL SEE B-N
47				UL SEE B-N
48				UL SEE B-N
49				UL SEE B-N
50				UL SEE B-N
51				UL SEE B-N
52				UL SEE B-N
53				UL SEE B-N
54				UL SEE B-N
55				UL SEE B-N
56				UL SEE B-N
57				UL SEE B-N
58				UL SEE B-N
59				UL SEE B-N
60				UL SEE B-N
61				UL SEE B-N
62				UL SEE B-N
63				UL SEE B-N
64				UL SEE B-N
65				UL SEE B-N
66				UL SEE B-N
67				UL SEE B-N
68				UL SEE B-N
69				UL SEE B-N
70				UL SEE B-N
71				UL SEE B-N
72				UL SEE B-N
73				UL SEE B-N
74				UL SEE B-N
75				UL SEE B-N
76				UL SEE B-N
77				UL SEE B-N
78				UL SEE B-N
79				UL SEE B-N
80				UL SEE B-N
81				UL SEE B-N
82				UL SEE B-N
83				UL SEE B-N
84				UL SEE B-N
85				UL SEE B-N
86				UL SEE B-N
87				UL SEE B-N
88				UL SEE B-N
89				UL SEE B-N
90				UL SEE B-N
91				UL SEE B-N
92				UL SEE B-N
93				UL SEE B-N
94				UL SEE B-N
95				UL SEE B-N
96				UL SEE B-N
97				UL SEE B-N
98				UL SEE B-N
99				UL SEE B-N
100				UL SEE B-N

# Appendix C: Exploded Parts Drawing

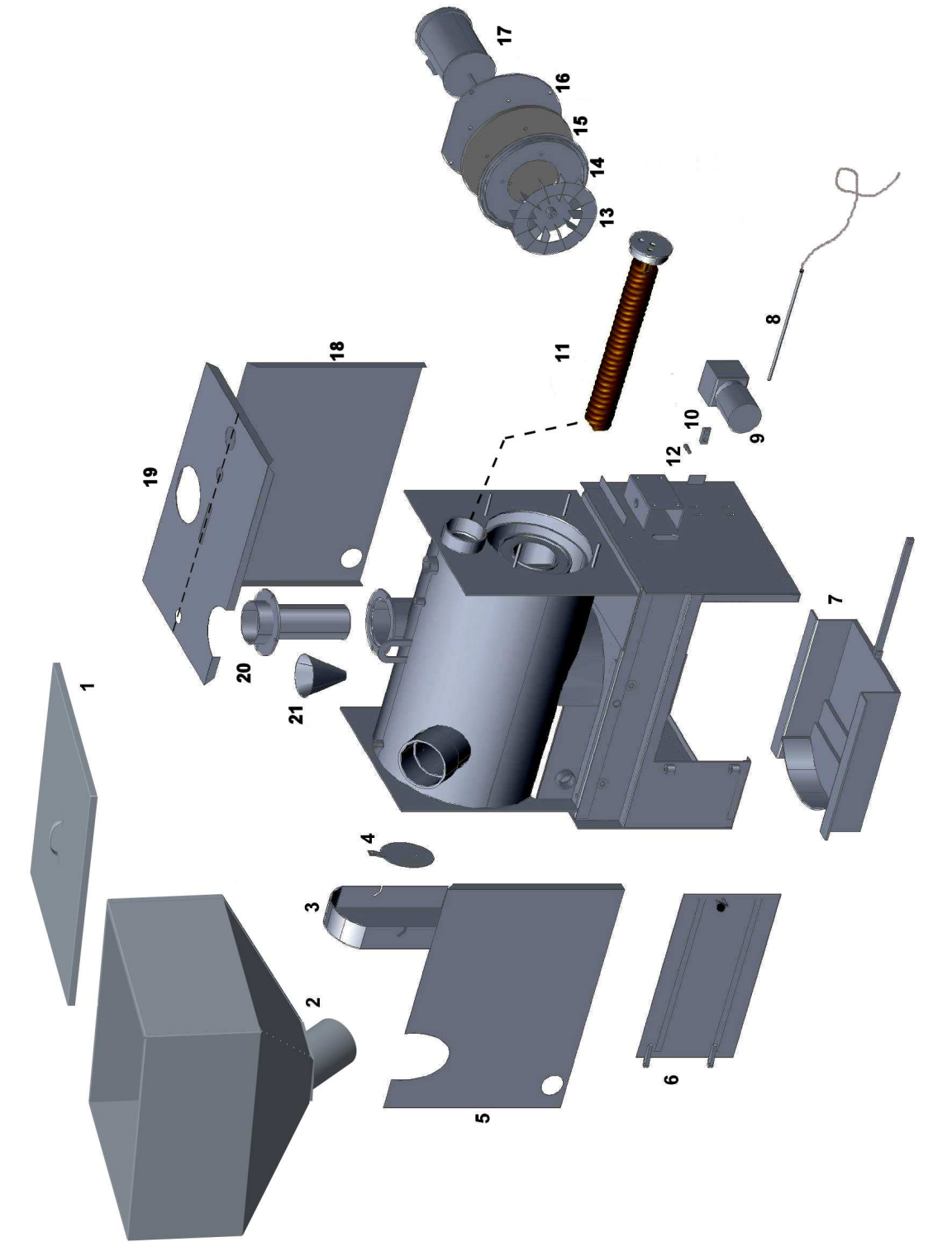



## Parts Listing

(As shown in diagram on previous page)

1. Hopper Lid
2. Coal Hopper
3. Draft Inlet Cover
4. Draft Inlet Flap
5. Right Insulation Cover
6. Grate Base Door (one on each side)+
7. Grate Assembly
8. Thermocouple for Thermo-Controlled Grates
9. Grate Motor
10. Pitman Block
11. Domestic Water Coil
12. Pitman Connecting Pin
13. Fan Disk
14. Abrasion Shield
15. Ceramic Heat Shield
16. Fan Motor Mounting Plate (Fan Cover)
17. Fan Motor
18. Left Insulation Cover
19. Top Insulation Cover (Two Pieces)
20. Flue Tube Assembly
21. Cyclone Funnel

## Appendix D: Maintenance

The Alternate Heating Systems Coal Gun™ is designed to provide years of reliable service. Nevertheless, it is necessary to provide basic service in order to maintain optimum efficiency and service from your boiler. We recommend that you have your authorized Alternate Heating Systems dealer provide the seasonal preventative maintenance service. If you decide to provide your own maintenance, the instructions provided here are to be used as a guide. Routine maintenance should be performed every three months on units in continuous operation and at least once each heating season on residential installations.

Before the boiler is serviced, shut off power to the boiler. The coal fire must be completely out. If the boiler has been actively firing, it may take days for the fire to go out completely. Make sure the coal pot, boiler and ash grate are cool.

---

### END OF SEASON CLEANING

---

Seasonal maintenance of the Coal Gun is simple but critical to maintaining top performance and longevity. To clean safely, wait until the fire has gone out and ash and water temperatures have cooled to ambient temperature. If in the process of cleaning you encounter hot ash or evidence of a still burning fire, stop and wait as long as needed to be sure the fire is extinguished and everything has cooled completely.

#### Cleaning Exhaust End of Swirl Tube

The swirl tube heat exchanger vents into the ash removal cyclone just under the opening for the flue connecting pipe. To access this area, disconnect your flue pipe from the top of the boiler. With the pipe removed, loosen the nuts on the Flue Tube Assembly flange as seen in the following photo.



**Flue Tube Assembly Bolted Flange**

When all the nuts are removed, the flue tube assembly can be removed as shown below. In some cases, it will be necessary to pry the flanges apart using an appropriate tool.



**Lifting Out the Flue Tube Assembly**

Set the Flue Tube Assembly aside and look down into the cyclone ash separator. You will see a square hole located where the boiler swirl tube exits into the cyclone. You can safely insert brushes and or a vacuum hose for cleaning through this port. Fly ash built up just inside this port will restrict airflow and

result in lower performance for the Coal Gun. Annual cleaning will help maintain like new performance.



**Square Swirl Tube Exit Port**

To clean through this opening with a vacuum hose, choose a hose that represents the largest diameter that will pass easily through the hole. Work the hose into the opening, then withdraw it with the vacuum running. Repeat the insertion and removal several times.



**Hose Inserted into Swirl Tube Heat Exchanger**

### **Cleaning Rear of Heat Exchanger**

It is also recommended to clean the heat exchanger from the rear of the boiler annually. This is accomplished by removing the fan assembly, then vacuuming and/or scraping the exposed surfaces of the fire tubes and swirl tube. Removing the fan assembly requires removing the nuts from the mounting bolts as shown in the following photo.

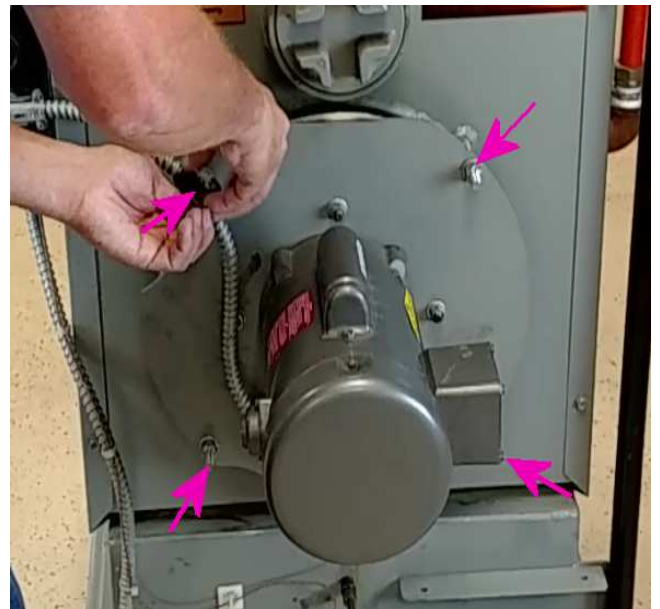

**Removing Fan Assembly**

Once the nuts are removed, carefully pull the fan assembly back directly off the mounting bolts, and set the fan assembly off to the side. The wiring harness for the fan is too short to allow setting the fan assembly directly on the floor, so a five gallon bucket or other temporary platform will be needed. As an alternative, you may disconnect the wiring harness from the motor, giving you more freedom about where you place it. Doing so is necessary for other maintenance tasks. Be sure to note proper connections for reattaching the fan assembly. Do not drop the assembly. Handle it carefully, as the ceramic heat shield is fragile, and becomes increasingly fragile over many heating/cooling cycles. It is a good idea to keep a spare.



**Set Aside Fan Assembly for Heat Exchanger Access**

Once the fan assembly is out of the way, you will have access to the fire tube and rear of the swirl tube

for cleaning. Long handled brushes and the AHS Swirl Tube Scraper are good tools to have ready at hand for this. The following photo shows the Swirl Tube Scraper for the S130 Coal Gun in use. It features a curved scraper head that matches the curvature of the heat exchanger.



**Swirl Tube Scraper**

When you are finished scraping the surfaces, vacuum the loose material out of the fire tube and swirl tube. In cases of severe build-up or neglect, more than one scraping and vacuuming cycle may be needed.

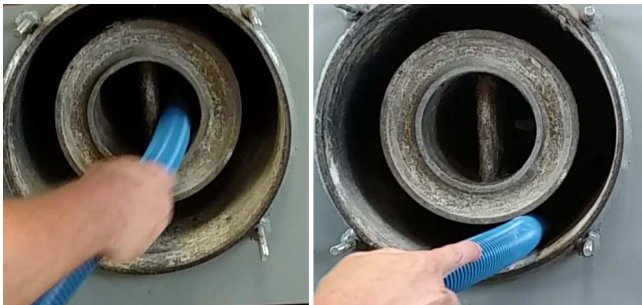

**Vacuuming Heat Exchanger**

When you are finished cleaning the rear of the heat exchanger, reinstall the fan assembly to the boiler. Use a bolt tightening pattern as shown in the following photo and no more than 15 – 20 lb-feet of torque. Using too much torque will result in crush damage to the ceramic heat shield.

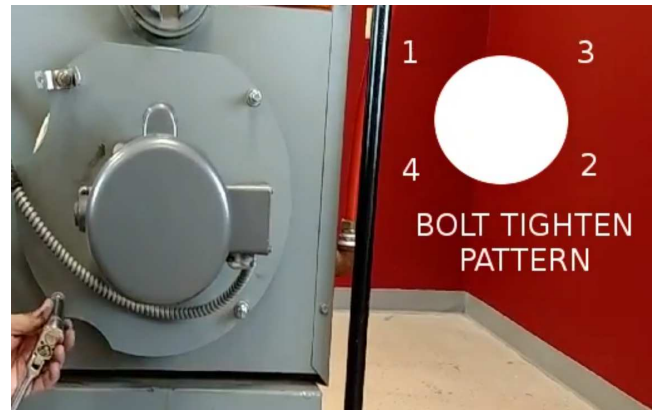

**Reinstall Fan Assembly**

Remember that cleaning of the heat exchanger, flue pipe and chimney is especially important at the end of the heating season to minimize corrosion during the summer months caused by accumulated ash. If your boiler is in a damp location, use any means available to reduce moisture in the area and humidity in the air. A heat source inside the fire tube of the boiler will help dry moisture inside the fire side and heat exchange surfaces. A piano heater or 40 watt incandescent rough surface light bulb are good for this task. Any free moisture will readily combine with residual fly ash and create sulfuric acid. This will cause rust and scale build-up on metal surfaces exposed to this combination.

---

### **CLEANING COAL POT, FEED TUBE AND GRATE**

---

Remove and clean the ash pan. Remove remaining coal from the hopper, coal pot and grate. Examine all areas for damage and clean as needed. Remove grate linkage arm and manually move grate back and forth to check bearing condition. Reassemble grate arm. Lubricate grate chain (if so equipped) with chain oil and check sprockets for wear.

Other routine maintenance items include:

- Drive belts (belt drive units only) and roller chains (if so equipped) should be inspected and tightened if necessary. To adjust drive belt tension and alignment, loosen motor mount bolts (belt drive units only) and slide motor so as to affect proper tension and

alignment. To adjust roller chain tension on grate system (on commercial units), loosen grate motor mount bolts and slide grate motor so as to affect proper chain tension. This will be accomplished when there is about ¼ inch of play in the roller chain.

- The fan shaft bearings on belt drive units should be lubricated with a small amount of high temperature service grease such as Drydene Prypoplex EB 2, or the equivalent.
- Several drops of oil should be placed on the pitman shaft bearing blocks.

The chimney connector and chimney should be inspected at least monthly during the heating season to determine if ash buildup has occurred. Pay close attention especially to horizontal runs. If ash accumulates on the walls of the stovepipe and chimney, it restricts the flow of air and reduces draft.

On units that have a direct drive fan, the motor bearing may need to be replaced as often as every two years. A high pitch whine on fan startup is an early indicator for bearing failure, and replacement is a good idea when this is observed. On belt drive fans, the pillow block bearings and belt should be checked every three months. After the initial burn of two to six hours shut the boiler down and retighten the pillow block bearing set screws. To tighten the fan belt, loosen the four bolts that hold the motor to the bracket. Slide the motor down and re-tighten, being careful that the motor is properly aligned with the fan shaft. Some models have a hinged motor mount with adjusting screws. To check for proper alignment of the pulleys, use a straight edge lying across both pulleys.

After reattaching the fan motor assembly to the boiler, turn the fan over by hand to ensure that it does not bind. If a tight spot is evident, loosen the locking pillow block collars on the shaft and move the shaft in until the fan touches the boiler and mark the shaft. Then pull the shaft out until the fan touches the abrasion shield and mark the shaft. Finally, position the shaft midway between the two marks and re-tighten the collars. Be certain to

replace the belt guard if it was removed for servicing.



**Belt-Driven Fan Assembly Removed from Boiler and Showing White Ceramic Heat Shield**

---

## FAN ASSEMBLY REMOVAL/REPAIR

---

This guide may be used for removal of the fan assembly and repair/removal of the fan impeller. This procedure is required when servicing the fan assembly or heat exchanger area. We recommend you contact Alternate Heating Systems for this repair procedure.

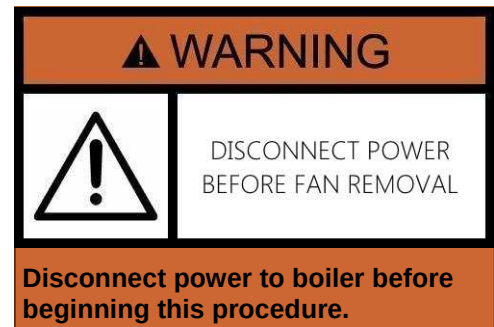

1. Remove electric wires and conduit at fan motor or junction box.

**Note: Mark connections before disconnecting wires.**

2. Remove the four nuts, which hold the fan assembly to the boiler. These are the outer circle of nuts on the fan plate.



3. Remove the fan assembly from the boiler and place on workbench.

4. Remove the two 1/4 - 20 square head set screws in the fan hub.

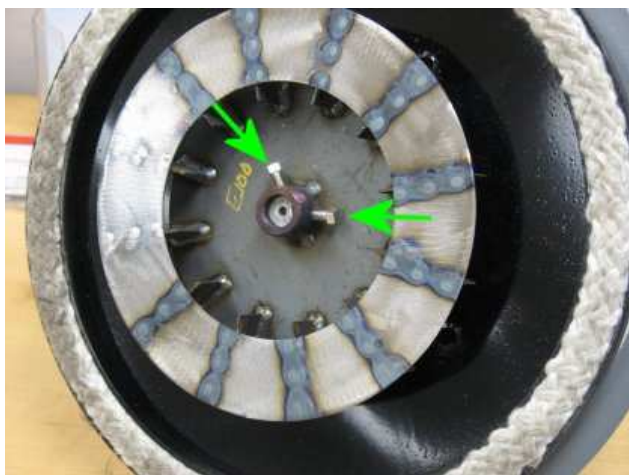

5. Thread a hex nut, size 1-14 (NF), to the hub of the fan.



6. Using a manual jaw puller attached to the 1-inch nut, carefully pull the fan from the motor shaft.



6.b. Alternately, you may use part number 01-10-80 100 FAN PULLER, as shown in following images, to remove the fan.





The Fan Puller [01-10-80 100] simplifies fan removal compared to the use of jaw type pullers. Suggested procedure is to remove the fan assembly and sit on a flat surface with the fan up. Soak the end of the fan hub inside the threaded fitting and on the exposed end of the motor shaft with a suitable penetrant. Let sit for a few hours, if possible. Loosen the setscrew on the hub (over the keyway). Attach the large nut of the fan puller to the threaded end of the hub and turn the bolt in toward the motor shaft to pull the fan off the shaft. It is likely that you will need to apply some heat to the fan hub in order to loosen it.

7. Clean shaft and apply a thin coat of anti seize lubricant to the shaft.

8. Place a new fan on the shaft, aligning one set screw hole with the keyed part of shaft. Notes: Fan hub should extend  $\frac{1}{4}$  inch beyond the shaft.

9. Apply anti seize to the two set screws and install both securing the fan to the shaft.

10. Attach fan assembly to boiler and reconnect the wires.

---

## DIRECT DRIVE MOTOR BEARING REPLACEMENT

---

This guide may be used for replacement of direct drive induction fan motor bearings. We recommend you contact your Alternate Heating Systems for this repair procedure.

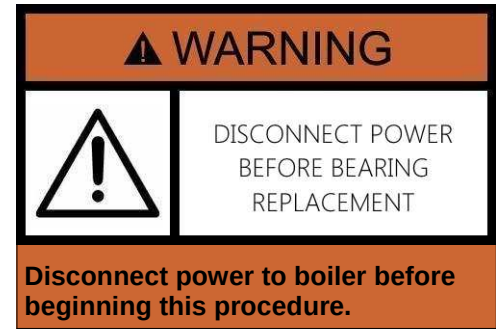

1. Follow steps 1 – 6 of Fan Assembly Removal/Repair procedure. These will guide the removal of the fan assembly.

2. On bottom of fan assembly, mark all components to assure it can be reassembled in the same orientation.

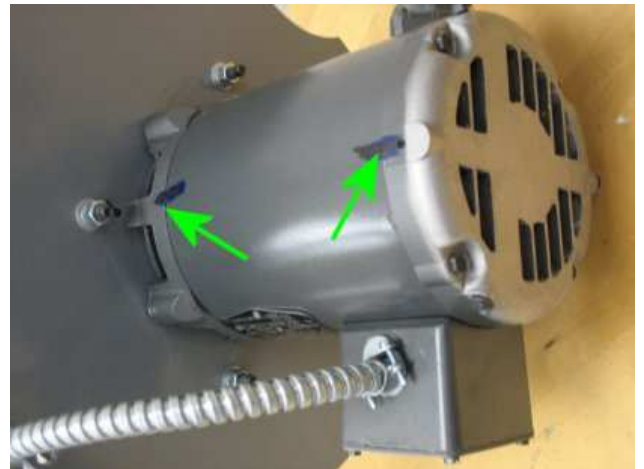

3. After fan is removed, remove abrasion shield by removing the nuts, which hold it to the fan plate. Note: these are the inner circle of nuts on the fan plate.

4. Using broad putty knife or pry bar, carefully remove the heat shield (ceramic insulation board) from the fan plate.



5. Using a hex key (allen wrench) remove the 4 countersunk screws, which hold the fan plate to the motor.



8. Set motor on back, shaft end up, on a workbench.

9. Using a small hammer, gently tap up on the end plate at shaft end.



6. Remove back cover (fan cover) from motor. The illustration in step 2 shows the motor with this cover already removed. It is secured with 3 screws on the outside of the motor.



10. The plate along with the armature will come loose which should be gently lifted out.



7. From back of motor, remove the four long screws holding motor and plates together.





11. Check to be sure the beveled (cupped spring) washer stayed in the end cap remaining with the motor housing.

12. Remove the two screws holding the bearing to the front end cap and gently tap end cap off.



13. Using a manual jaw puller, remove bearing from shaft.



14. Install new bearing. Do not apply force on outer bearing race.

---

### ADDITIONAL INFORMATION

---

For additional information on using your boiler safely, obtain a copy of the National Fire Prevention Association publication “Using Coal and Wood Stoves Safely”, NFPA No. HS-8-1974. The address of the NFPA is 470 Atlantic Avenue, Boston, Massachusetts 02 210. You can also find them online at: [www.nfpa.org](http://www.nfpa.org)

## Operation and Maintenance Schedule for Models S130 and S260

Interval	Item	Procedure
As Needed	Ash removal	Remove ash and observe condition of ash. Adjust grate timer if necessary.
Weekly	Fire bed (when burning poor quality coal)	Check for clinkers and remove if necessary. Note: Poor quality coal produces clinkers.
Every 3 months	Roller chains	Lubricate with chain oil and take up slack.
Every 3 months	Drive belt	Check belt condition. Replace or adjust tension.
Every 3 months	Fan shaft bearings (belt drive models only)	Grease with high temperature grease. Check and tighten set screws on the shaft and pulleys.
Every 6 months	Abrasion shield	Check for leakage around gasket. Adjust or replace if necessary.
Every 6 months	Flue pipe	Check for leakage around seams and re-seal if necessary.
End of season	Cam bearing on grate.	Check to make sure bearings are free to rotate.
End of season	Fire box	Clean and inspect fire box.
End of season	Swirl chamber	Clean and Remove any buildup with a boiler brush. Inspect fan condition. Look for cracks and wear.
End of season	Ceramic heat shield	Check for wear around fan shaft hole- replace if gap is greater than 1/16".
End of season	Flue pipe	Remove flue tube assembly and clean. Inspect cyclone funnel.

## Appendix E: Troubleshooting Guide

Problem	Possible Cause	Solution
1. Boiler overheating	<ul style="list-style-type: none"> <li>a) Sight hole cover flap not releasing when fan stops</li> <li>b) Excessive chimney draft</li> <li>c) Aquastat set too high or malfunctioning</li> </ul>	<ul style="list-style-type: none"> <li>a) Check spring for proper tension</li> <li>b) Install barometric damper in flue</li> <li>c) Reduce aquastat setting or replace aquastat</li> </ul>
2. Pressure relief valve vents	<ul style="list-style-type: none"> <li>a) Expansion tank too small or "water logged"</li> <li>b) High limit aquastat not functioning</li> </ul>	<ul style="list-style-type: none"> <li>a) Add expansion tank capacity necessary for total volume of water in system or replace water logged tank</li> <li>b) Check wiring and replace aquastat if malfunctioning</li> </ul>
3. Coal pot not full of coal	<ul style="list-style-type: none"> <li>a) Hopper empty or obstruction in coal hopper</li> <li>b) Excessive fines, wet coal</li> </ul>	<ul style="list-style-type: none"> <li>a) Check hopper</li> <li>b) Use dry coal and watch fines</li> </ul>
4. Coal burns up inlet tube	<ul style="list-style-type: none"> <li>a) Grate switch turned off</li> <li>b) Grate not removing spent ash</li> <li>c) Fused coal (clinkers) in coal pot</li> <li>d) High demand coupled with low performance</li> </ul>	<ul style="list-style-type: none"> <li>a) Turn on Grate Switch</li> <li>b) Check for problem in grate motor circuit or mechanical linkage</li> <li>c) Remove clinkers (fused coal ash)</li> <li>d) Check problem item numbers 7, 9,</li> </ul>
5. Fire goes out	<ul style="list-style-type: none"> <li>a) Insufficient demand to maintain fire</li> <li>b) Large clinkers</li> </ul>	<ul style="list-style-type: none"> <li>a) Increase heat load</li> <li>b) See paragraph at end of troubleshooting guide</li> </ul>
6. Excessive fly ash in chimney	<ul style="list-style-type: none"> <li>a) Cyclone funnel plugged</li> <li>b) Flue pipe between boiler and chimney too long.</li> </ul>	<ul style="list-style-type: none"> <li>a) Check cyclone funnel and remove restriction.</li> <li>b) Reduce length of pipe run</li> </ul>
7. Fly ash build-up on swirl tube	<ul style="list-style-type: none"> <li>a) Condensation causing fly ash to stick to heat exchange surfaces.</li> </ul>	<ul style="list-style-type: none"> <li>a) Raise return water temperature, check problem item 9</li> </ul>
8. Excessive sulfur odor in boiler room	<ul style="list-style-type: none"> <li>a) Coal quality low</li> <li>b) Chimney draft problem:</li> <li>c) Down draft</li> <li>d) Restriction in Chimney</li> <li>e) Cyclone funnel on Coal Gun has deteriorated</li> </ul>	<ul style="list-style-type: none"> <li>a) Find better quality coal</li> <li>b) Inspect chimney</li> <li>c) Check chimney design &amp; improve</li> <li>d) Check &amp; clean chimney</li> <li>e) Replace cyclone funnel</li> </ul>
9. Poor boiler performance	<ul style="list-style-type: none"> <li>a) Inadequate air for combustion</li> <li>b) Obstruction to air flow inside boiler or venting system</li> <li>c) Excessive ash in coal pot</li> </ul>	<ul style="list-style-type: none"> <li>a) Supply adequate air supply to boiler room</li> <li>b) Inspect and clean swirl chamber. Remove and clean cyclone insert, check for chimney obstruction</li> <li>c) Adjust ash removal controls. Setting Thermal Ash Monitoring Control higher will lower position of fire and reduce amount of ash in coal pot.</li> </ul>
10. Coal gas ignitions (evidenced by an audible bang)	<ul style="list-style-type: none"> <li>a) Poor draft</li> <li>b) Too much raw coal on top of coal pot</li> </ul>	<ul style="list-style-type: none"> <li>a) Assure at least -.04" of WC with a manometer. Increase flue height if necessary, or use an auxiliary power vent, make sure there are no obstructions in chimney or any part of venting system</li> <li>b) Raise position of the fire and shrink zone occupied by raw coal – This is accomplished by setting a lower temperature on the Thermal Ash Monitoring Control. If this setting is already at 110° F or lower, consider adjusting grate timers.</li> </ul>

---

## CHECKING/REMOVING CLINKERS

---



Clinkers are clumps of ash from burned coal that have been fused together. Some coal is more prone to create clinkers due to a low ash fusion temperature. Coal that is prone to forming clinkers can often be observed to increase the amount of unburnt coal showing up in the ash pan, as pieces of coal adhere to the fused ash and are removed with the clinkers without being fully burned. Higher combustion temperatures can also increase clinker formation. These in turn are connected with higher duty cycles, high grate temperature settings,

and on belt drive systems, increasing the velocity of the induction fan with non factory pulley arrangements. Clinkers can be reduced or eliminated by changing the settings of the ash controller on the boiler. Clinkers that are approximately baseball size or smaller will be carried to the ash pan. Larger sized clinkers could cause the fire to go out if the boiler is unable to remove them.

To help remove large clinkers, remove the draft flap cover and move draft flap to the side. Be sure to wear gloves to provide protection against burns. Insert a metal rod in the sight tube and run it up and down (to the grate) through different areas of the coal pile checking for clinkers. Use the rod to break up any clinkers you find. If necessary, you can use a hammer to strike the end of the rod to break them up. You will not damage the grate if you hit it as it is made of 1/2" steel. Once the clinkers are broken up they will fall on to the grate and be carried to the ash pan.

## Appendix F: Table of Figures

## Appendix G: Programming Grate Control

**Note:** Your grate control comes preprogrammed from the factory. If you merely wish to change the temperature (set value, SV) at which the grate operates, this is accomplished by going directly to step 5 on the next page (Setting Grate Operation Control):







---

## DWYER 16C-2 PROGRAMMING









---

### Initial Programming









#### 1. Selecting Input Type

- A. Hold  button for three seconds, until you see: 
- B. Scroll with  or  until you see input type: 
- C. Press 





#### 2. Setting Temperature Unit

- A. Hold  button for three seconds, until you see: 
- B. Press  repeatedly until you see 
- C. Scroll with  or  until Fahrenheit is selected 
- D. Press  twice



#### 3. Setting Control Method

- A. Hold  button for three seconds, until you see: 
- B. Press  repeatedly until you see 
- C. Use  or  until the readout shows 
- D. Press  twice.





#### 4. Setting Temperature offset for Grate Control (Heating Hysteresis)

- A. Press , the top LED readout will display 
- B. Use the  or  to set the bottom readout to a value of 1
- C. Press  twice

#### 5. Set Grate Operation Temperature

Use  and  to select temperature. When the desired temperature setting is shown in the bottom readout, press . The grate operating temperature is set at the factory to 130° F. When the ash temperature drops to 1° (or whatever offset value is entered in step 4.) below the set value the grate system will remove ash.

### LOCKING CONTROL

Press  twice, LOC will be displayed, press  to set bottom readout to 1, Press   
UNLOCKING CONTROLS Press  and  at the same time (until display blinks). Then set the operation temperature, as in step 5. (Set Grate Operation Temperature) above.



# Appendix H: Dump Zone Wiring Applications

THE HIGH SIDE IS  
OPERATING WITH 120VAC

THE LOW SIDE IS  
OPERATING WITH 24VAC

DO NOT JUMP THE  
'R' TERMINALS TOGETHER

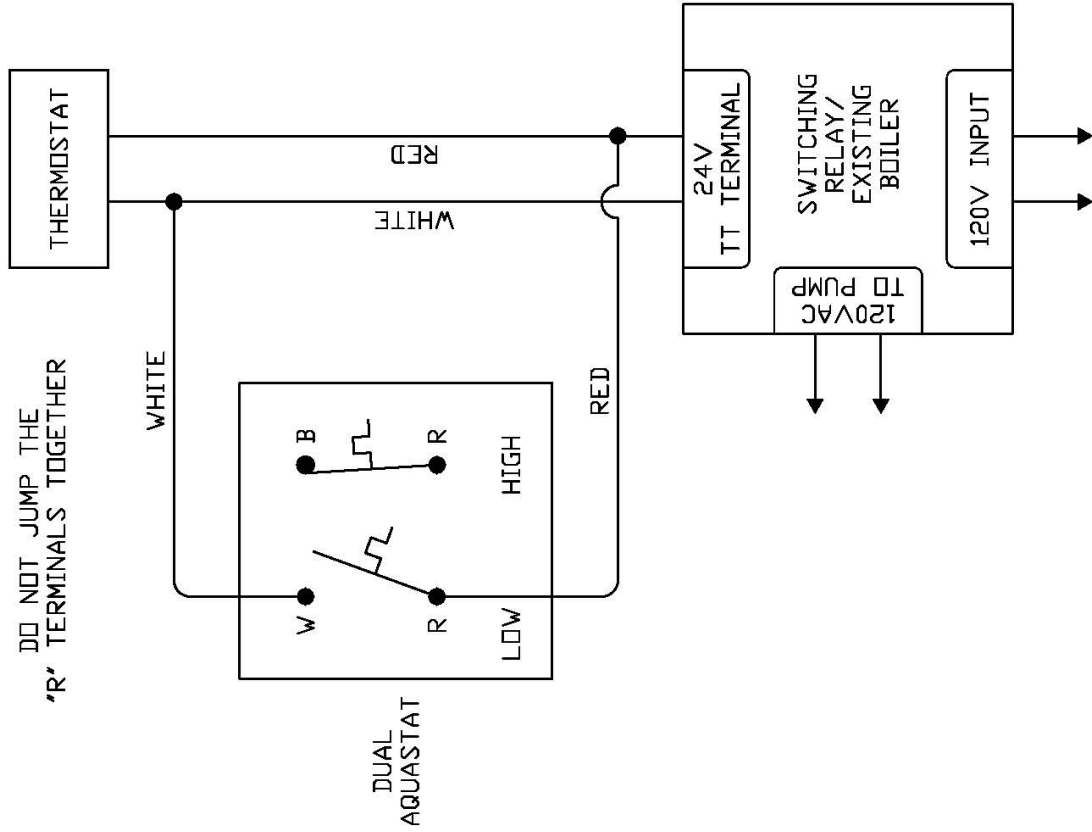

NO.	DATE	BY	CHKD.	REV.
1	11/07/11	GLS	NTS	0
DRAWN BY		SIZE	DRAWING	REV.
REV. 0		A	ELEC. SCHEM.	0

ALTERNATE HEATING SYSTEMS	
FUNCTIONAL	DATE
PARALLEL THE THERMOSTAT	

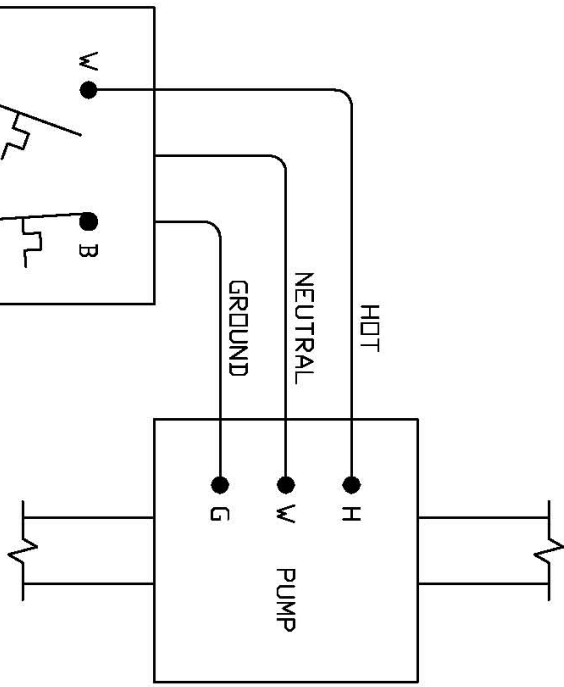

JUMP THE 'R'  
 TERMINALS TOGETHER  
 NEUTRAL AND GROUND  
 WIRES PROVIDED IN  
 THE DUAL AQUASTAT

120VAC PUMP SHALL BE  
 NO MORE THAN 3 AMPS  
 IT IS ADVISABLE TO USE  
 SAME CIRCUIT AS BOILER  
 TO POWER PUMP

120VAC PUMP SHALL BE NO MORE THAN 3 AMPS IT IS ADVISABLE TO USE SAME CIRCUIT AS BOILER TO POWER PUMP	
<b>ALTERNATE HEATING SYSTEMS</b>	
DESIGNATED PUMP FOR DUMP ZONE	N/A
DRAWING SIZE	11/07/11
ELEC. SCHEM.	REV. 0

**Example 2: Multiple Zone Valves**  
(120 volt wire connected to Red)

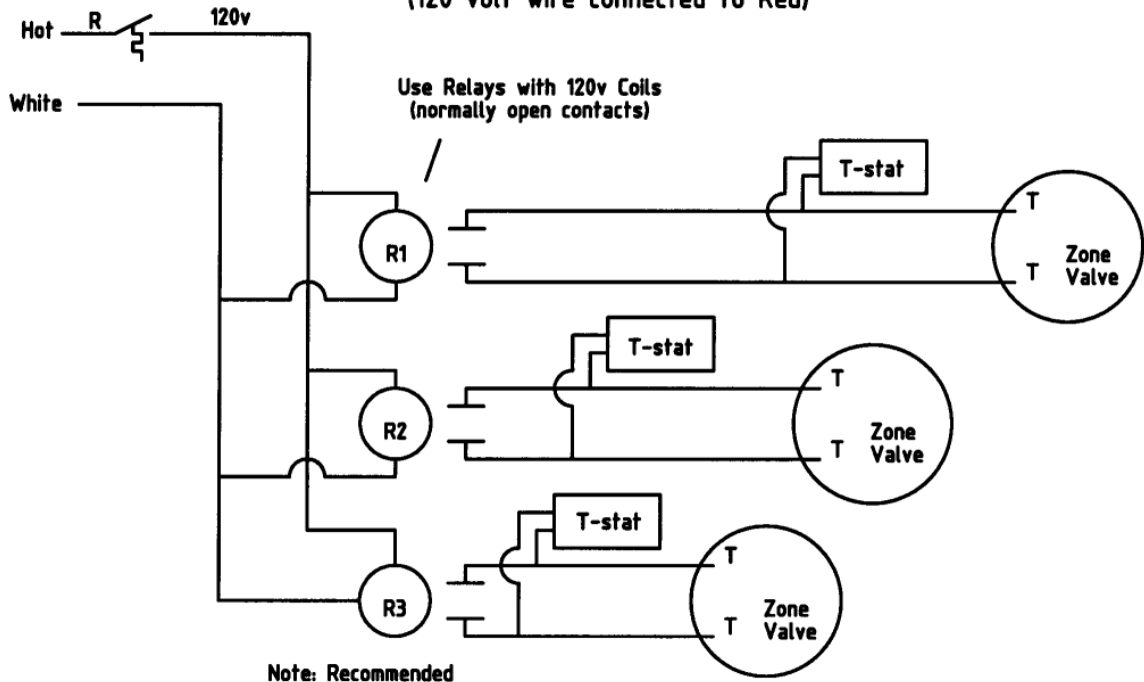

**Note: Recommended relay is RIBU1C by Functional Devices**

### Example #3 Single Zone Circulator

(120 volt wire connected to R)

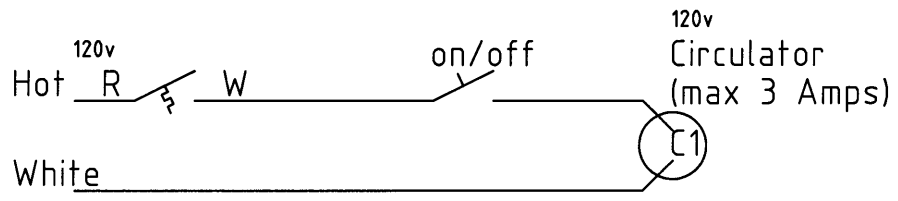

### Example #4

Use of Dump Zone without use of  
120v wire. The control is used as a  
dry contact switch (low voltage application).  
Use 300v or higher THHN or THWN rated  
wire.

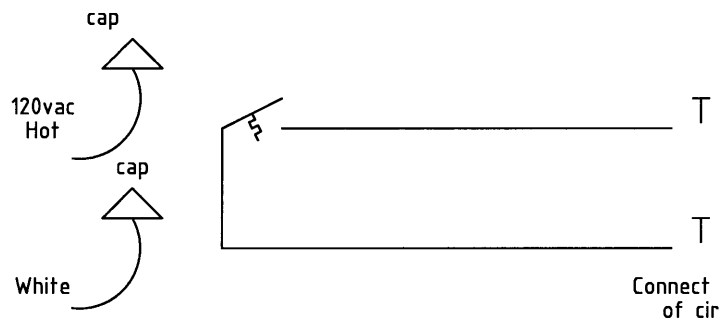

Do not use provided wires  
with this applicaton.

Connect to TT terminals  
of circulator relay.  
(Low voltage application)

# Dump Zone Example 5

(Domestic Water used as Dump Zone)

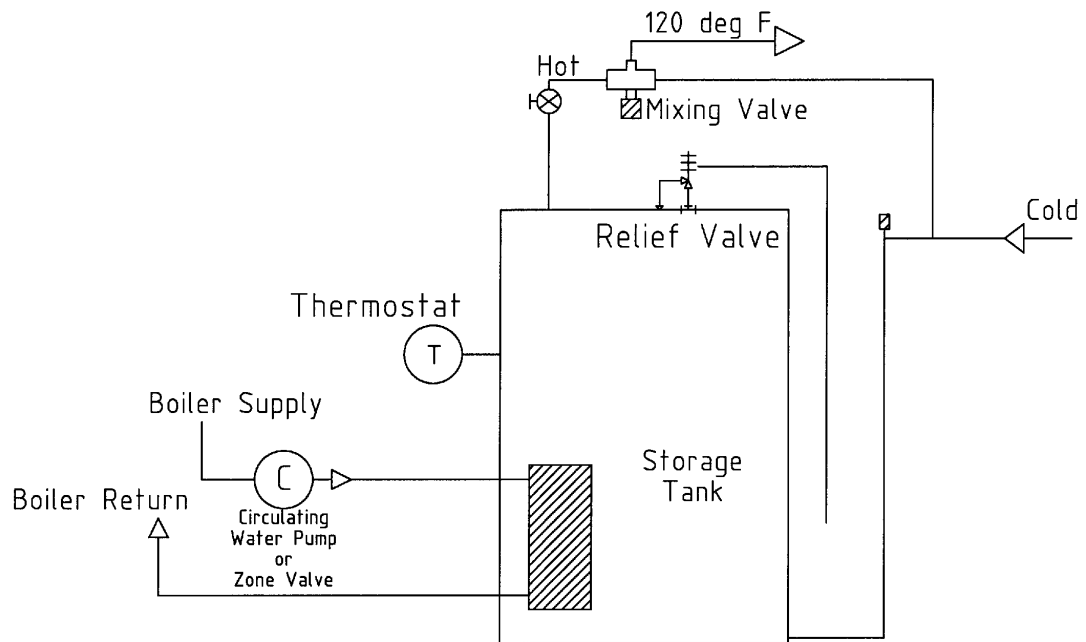

# Appendix I: Boiler Piping Examples

## Coal Gun used in a Primary/Secondary System

## Coal Gun used in a Primary/Secondary System

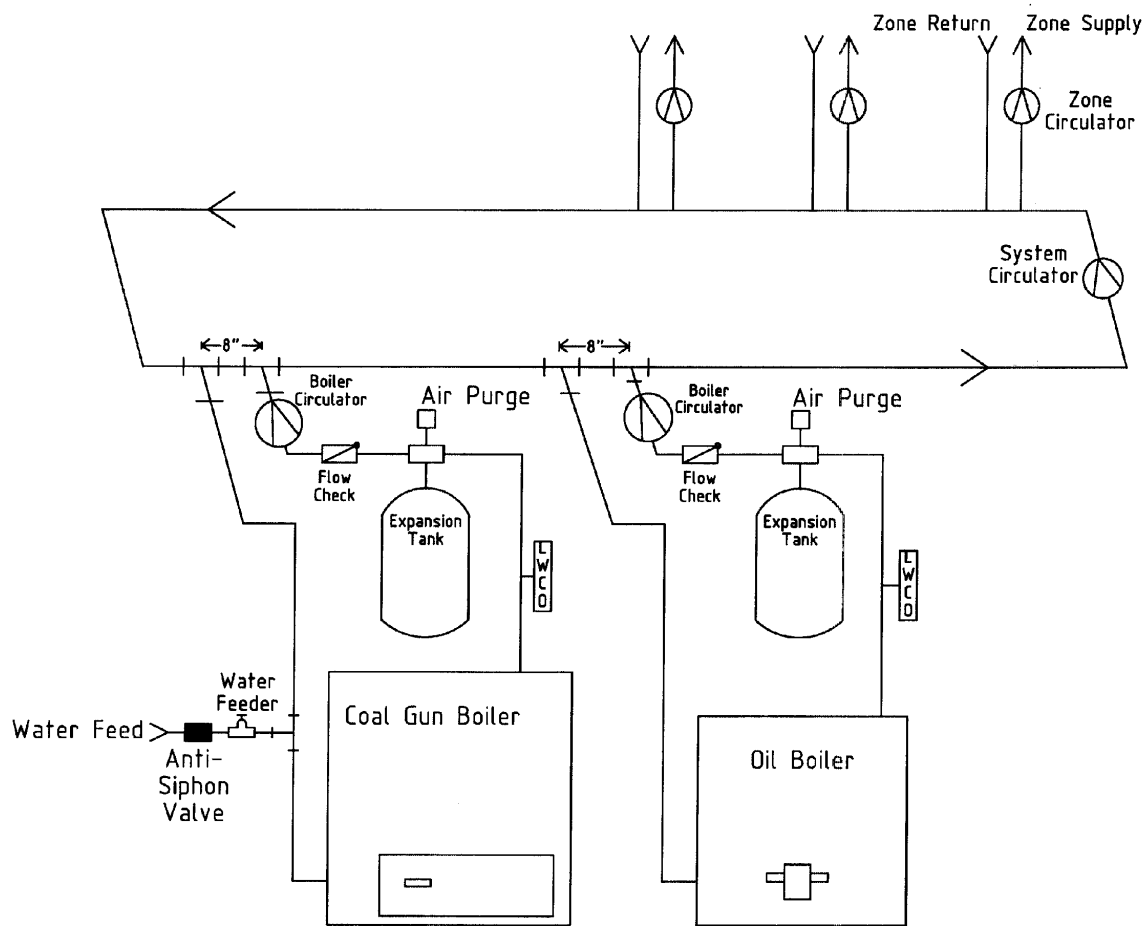

### Note:

1. A call for heat from any zone activates Boiler Circulators, System Circulator and Zone Circulator.
2. Each Boiler Circulator is also controlled by a low limit to prevent operation when the Boiler is cold.
3. Dump zone operation will activate one or more zones, System Circulator and Boiler Circulator.
4. Do not bypass temperature supply control system on radiant heat system. In radiant heat applications, permit activation of a call for heat but allow system controls to regulate water temperature.

Not all system components, valves and devices are shown in this drawing. Actual conditions and application requirements will vary. Please consult a heating expert or your Alternate Heating Systems dealer for additional information.



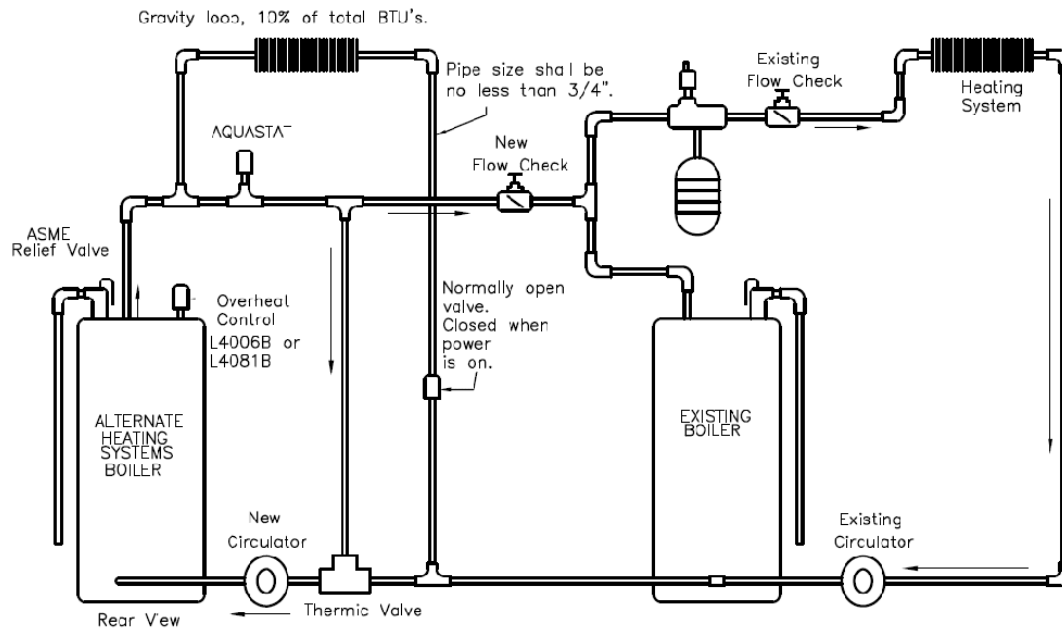

**Note:** The above illustrates one possible method of connecting the Coal Gun™ with an existing boiler. This connection is as follows: using a small circulator (and with the backup boiler piped into the return tapping) run another pipe from the supply tapping T, of the Coal Gun to the supply line, of the existing boiler on the lower side of the flow control valve. A minimum of 1" diameter pipe should be used for this connection on the model S130. The pipe size must be determined by taking into account the distance involved and flow required. The new circulator should be wired to the power for the Coal Gun. When power to the Coal Gun is on, the circulator should be running. An alternate option is to attach a strap on aquastat on the Coal Gun supply line that closes on temperature rise. This will automatically activate the pump at a given temperature. The add-on boiler shall be installed without interfering with the normal delivery of heated water from the original boiler. The add-on boiler shall be installed without affecting the operation of the electrical and mechanical safety controls of the original boiler.

# LIMITED WARRANTY

COAL GUN™ COAL STOKER BOILERS: S130 • S260

The manufacturer, ALTERNATE HEATING SYSTEMS, warrants to the original owner, for the periods specified below, that the boiler to which this warranty applies is free from defects in materials and workmanship when installed, operated, and maintained in accordance with the printed instructions supplied with the unit.

A. WHAT IS COVERED AND FOR HOW LONG (all from date of original installation)

- 1) Boiler Vessel, twenty (20) years pro-rated (pro-rated as follows: 1st to 10th year – full: 11th year – 40%: 12th year – 30%: 13th year – 20%: 14th year – 10%: 15th – 20th year – 10%) This does not cover any corrosion or deterioration in boiler vessel due to improper PH levels in water.
- 2) All electrical and plumbing components and controls such as temperature/pressure gauge, safety relief valve, aquastat controllers, electric motor, domestic hot water coil, oil burner, fan shaft bearings, timer, draft motor, etc. purchased by Alternate Heating Systems from other manufacturers are limited to warranties offered by those manufacturers, typically One (1) year.
- 3) V-belt, pulleys, fan heat shields, fasteners, gasket and silicone rubber seals, door handle knobs, paint, wiring, and wiring devices -Thirty (30) days.
- 4) Coal Gun™ Grate – Lifetime

B. WHAT WE WILL DO AND NOT DO

- 1) Alternate Heating Systems will repair and replace, at our option, units or component parts found defective after inspection by Alternate Heating Systems or our authorized representative during the periods outlined above.
- 2) Alternate Heating Systems SHALL NOT BE LIABLE UNDER THIS WARRANTY IF:
  - a) The unit or any of its component parts have been subject to misuse, alteration, unauthorized repair, neglect, accident, or damage from handling.
  - b) The unit is not installed, operated and maintained in accordance with the printed instructions supplied with the unit and in accordance with local plumbing and/or building codes.
  - c) The unit is operated above its rated output which is shown on the nameplate attached to the unit and listed in Alternate Heating System's printed literature.
  - d) The unit is fired with fuels other than those recommended by Alternate Heating Systems. This includes fuels recommended by dealers and distributors selling Alternate Heating Systems products if these are not fuels recommended by Alternates.

C. WHAT THE CUSTOMER MUST DO

- 1) Contact the dealer who sold you the unit.
- 2) If said dealer cannot be located, contact any other Alternate Heating Systems dealers in your area.
- 3) If you are unable to locate a dealer, submit your warranty claim directly to Alternate Heating Systems at the address listed below.
- 4) When you make an inquiry or warranty request, be sure to include the following information:
  - a) Unit model number
  - b) Serial number
  - c) Date of installation
  - d) Dealer's name
  - e) Type of fuel burned
- 5) The OWNER and not Alternate Heating Systems or its dealers will be liable for the following costs involved in repair or replacement of the defective unit or component part
  - a) All necessary costs in returning the defective unit or component part to the factory or other location designated by Alternate Heating Systems.
  - b) All freight and delivery costs of shipping a new or required unit or replacement component part to the owner.
  - c) All labor and other costs incurred in the removal of the defective unit or part and installation of a new or required unit or part.
  - d) Any material required to complete installation of new or required unit or replacement part.

D. LIMITATIONS AND STATE LAW RIGHTS

- 1) Alternate Heating Systems neither assumes nor authorizes any representative or other person to assume for it any other obligation or liability in connection with its products other than expressly written here.
- 2) Implied warranties of merchantability and fitness for a particular purpose are limited to the duration of this LIMITED WARRANTY.
- 3) Alternate Heating Systems shall not be liable for any incidental or consequential damages such as water, smoke or heat damage to property arising directly or indirectly from any defect in its products or their use.
- 4) Some states do not allow limitation on how long an implied warranty lasts and the exclusion or limitation of incidental or consequential damages, so the above limitations and exclusions may not apply to you.
- 5) This warranty gives you specific legal rights and you may also have other rights, which vary from state to state.
- 6) The remedies set forth herein shall be the exclusive remedies available to the owner.

ALTERNATE HEATING SYSTEMS  
2393 LITTLE EGYPT RD  
HARRISONVILLE, PA 17228  
(717)-987-0099 ALTERNATEHEATINGSYSTEMS.COM

**IMPORTANT: READ AND KEEP IN YOUR POSSESSION!**