



INSTALLATION AND OPERATOR'S MANUAL

COMMERCIAL APPLICATIONS

COAL GUN™ BOILER

Models: S260, S500, S1000



IMPORTANT: IN ORDER TO ACHIEVE SAFE AND SATISFACTORY RESULTS FROM YOUR ALTERNATE HEATING SYSTEMS, INC. BOILER, READ SAFETY RULES AND INSTRUCTIONS CAREFULLY BEFORE INSTALLING AND OPERATING. ALL INSTALLATIONS MUST BE IN ACCORDANCE WITH STATE AND LOCAL CODES. SAVE THESE INSTRUCTIONS FOR FUTURE REFERENCE.



WARNING: Your Alternate Heating Systems Boiler is capable of generating very hot temperatures. Boiler temperatures and flames in the ignition box area are capable of causing ignition or explosion of explosive or flammable products or explosion of the boiler itself if maximum safe water temperature is exceeded. Maximum safe water temperature is 210⁰ Fahrenheit. Flammable or explosive products must never be stored in the same room or in the vicinity of a boiler, and the boiler water temperature must never be allowed to exceed 210⁰ Fahrenheit.

Economical Energy Consultants, LLC
2395 Little Egypt Road
Harrisonville, PA 17228
Service: Jeff Gingerich 717-360-6828 /
jeff@ecoenergyconsultant.com

Record Model and Serial Number Below

Model:

Serial:

Copyright 2000 – 2012 Alternate Heating Systems, LLC.

No portion of this publication may be reproduced without the express written consent of Alternate Heating Systems, LLC.

Coal Gun boilers bearing the mark seen at right are thereby designated as Compliant.

The Coal Gun™ has undergone thorough testing and is certified with Underwriter's Laboratories test standard 5253-2009 and Canadian Test Standard: CSA B366.1-2011



Revision: 061112

TABLE OF CONTENTS

INTRODUCTION.....	1
BOILER INSTALLATION.....	2
BOILER LOCATION.....	2
<i>Boiler Room Requirements.....</i>	<i>2</i>
RIGGING AND POSITIONING OF BOILER.....	2
CLEARANCES REQUIRED FOR SAFETY AND OPERATION	3
GENERAL CHIMNEY REQUIREMENTS.....	3
<i>Technical Aspects of Chimney Performance.....</i>	<i>4</i>
STOVEPIPE	4
PROPER CHIMNEY CONNECTION	5
Figure 1: Proper chimney connection	5
Figure 2: Stove pipe passing through wall	6
IN CASE OF CHIMNEY FIRE	6
COMBUSTION AIR SUPPLY.....	6
DRAFT CONTROLS	6
<i>How Draft Controls Work.....</i>	<i>7</i>
<i>Choosing the Right Size.....</i>	<i>7</i>
(Sizing the Control).....	7
BOILER PIPING FOR HYDRONIC SYSTEMS.....	10
<i>Piping the Boiler in Parallel with another Boiler.....</i>	<i>10</i>
<i>Pressure Relief Valve</i>	<i>10</i>
Figure 3: Pressure regulating valve and backflow prevention valve configuration.....	11
BOILER CONDITIONER / SEALANT	11
BOILER PIPING AND CONTROLS FOR STEAM SYSTEMS.....	11
FORCED HOT AIR SYSTEMS (WATER TO AIR COIL IN DUCT)	12
DOMESTIC HOT WATER COIL PIPING	12
Figure 4: Plumbing – Coil in Series.....	12
Figure 5: Plumbing – Coil in Parallel.....	13
Figure 6: Tempering valve	13
Figure 7: Plumbing – Coil with circulator	13
ILLUSTRATED INSTRUCTIONS FOR INSTALLING COAL HOPPER.....	13
ELECTRICAL CONNECTIONS IN THE COAL GUN™	14
<i>S130/S260.....</i>	<i>14</i>
<i>S500/S1000.....</i>	<i>14</i>
CONTROLS.....	14
<i>Control Settings.....</i>	<i>14</i>
<i>Steam.....</i>	<i>16</i>
BOILER DUMP ZONE APPLICATIONS.....	16
<i>Non Powered Dump Zone</i>	<i>17</i>
Figure 9: Non-Powered Dump Zone.....	17
OPERATING INFORMATION.....	18

LIGHTING THE COAL GUN™	18
OPERATION OF SIGHT HOLE COVER	19
Sight Tube Cover in Open Position.....	19
Sight Tube Cover in Closed Position	19
SHUTTING DOWN THE COAL GUN	19
AUTOMATIC FUEL DELIVERY SYSTEMS.....	20
BASIC AUGER OPERATION.....	20
AUGER ASSEMBLY	21
THERMO ASH-MONITORING GRATE CONTROL OPERATION	21
REMOVAL AND DISPOSAL OF ASHES	21
CONDITIONING OF BOILER WATER	21
Ph.....	22
DISSOLVED OXYGEN	22
SULFITES	22
SOLIDS	22
ALKALINITY	22
PHOSPHATES.....	22
HARDNESS	23
OILS	23
APPENDIX A: BOILER SPECIFICATION DIAGRAMS.....	24
ADDITIONAL SPECIFICATIONS	26
<i>Pressure Drop</i>	26
<i>Explanation of GPM Flow</i>	26
APPENDIX B: WIRING DIAGRAMS	27
APPENDIX C: EXPLODED PARTS DRAWING.....	31
<i>Parts Listing</i>	31
(As Shown in Exploded Parts Diagram)	31
APPENDIX D: MAINTENANCE.....	33
CLEANING HEAT EXCHANGER AND VENTING SYSTEM	33
CLEANING COAL POT, FEED TUBE AND GRATE	33
Belt-drive fan assembly removed from boiler and showing white gasket	34
FAN ASSEMBLY REMOVAL/REPAIR	34
DIRECT DRIVE MOTOR BEARING REPLACEMENT	35
ADDITIONAL INFORMATION	38
OPERATION AND MAINTENANCE SCHEDULE FOR MODELS S130, S260, S500 AND S1000	39
APPENDIX E: TROUBLESHOOTING GUIDE.....	40
APPENDIX F: TABLE OF FIGURES.....	42
APPENDIX G: PROGRAMMING GRATE CONTROL	43
Dwyer 16C-2 PROGRAMMING.....	44
<i>INITIAL PROGRAMMING</i>	44
<i>LOCKING CONTROL</i>	44

APPENDIX H: DUMP ZONE WIRING APPLICATIONS 45
APPENDIX I: BOILER PIPING EXAMPLES..... 51
 Coal Gun used in a Primary/Secondary System 52
LIMITED WARRANTY 54

INTRODUCTION

The purpose of this manual is to assist you in the installation, operation and maintenance of your new boiler in order to achieve the best performance possible. **The boiler unit shall be installed by a qualified and experienced boiler installation technician who has a thorough knowledge of hydronic heating systems and boilers and will comply with all requirements of AHJ.** Should your installation require a steam boiler, it is even more important that experienced personnel be consulted to ensure that the necessary safety controls are installed and properly wired.

Read the entire instruction manual carefully and understand it thoroughly before installing or operating this unit. **SAVE THESE**

INSTRUCTIONS and review them periodically to refresh your memory regarding safe operating practices and routine maintenance required.

All Alternate Heating Systems, LLC. Boilers can be supplied with the ASME “H” stamp and National Board number for an additional fee when requested prior to purchase. Alternate Heating Systems boilers are built to rigid quality control standards. You can be assured of receiving a high quality product.

BOILER INSTALLATION

BOILER LOCATION

Wood & Coal Burning Boilers are designed to radiate as much heat as possible, but this heat can be dangerous if the boiler is improperly installed.



CAUTION:

A building fire could be started if the boiler is installed too close to walls, furniture, carpet or draperies.

The boiler must stand on a noncombustible material such as brick, stone tile or concrete. **NEVER** place a boiler directly on a wood floor. The noncombustible material upon which the boiler stands should extend at least 12 inches beyond the base of the boiler in the rear and on the sides and at least 36 inches in front. The boiler must be installed in an area dedicated to the boiler and its related equipment. This area must be partitioned or separated from any living area of a residence. The room must have a constant fresh air supply to assure proper combustion of the fuel as well as ventilation of any by-products of combustion.

Boiler Room Requirements

1. The room should be well lighted and should have a source of emergency light.
2. A convenient water supply should be available for boiler flushing and to clean the boiler room floor.
3. Unobstructed floor drains.
4. A boiler must not be installed where there is the possibility of the accumulation of explosive vapors.

5. Must have adequate air supply, which must be kept clear at all times. Since the combustion process requires a supply of air at all times, it is essential that provisions are made to supply adequate air to the boiler room. This air supply is necessary to insure complete combustion and venting of any gases or smoke that would be emitted from this solid fuel-burning boiler in case boiler malfunctions.

Note: Ventilation fans in the boiler and fuel storage rooms must not create negative pressure, as this would adversely affect boiler operation. This applies at the room location of the intake end of the auger as well

6. Electrical disconnect at point of entrance to boiler room.
7. Walls and ceiling must be of fire-rated construction. Consult local or state codes for requirements.

RIGGING AND POSITIONING OF BOILER

Do not attempt to move or off-load the boiler without the aid of a crane or dolly. All Alternate Heating Systems boilers have at least one lifting lug in the center of the top. On some units lifting lugs in the front and rear are provided. Use caution whenever moving a boiler. When choosing the equipment to move and/or position the boiler, always be sure of the load rating on the equipment prior to use.

A ratchet puller (come along) device may be needed to move a boiler where the ground level changes in elevation. AHS suggests that professional movers should be used in any unpredictable situation. This is to prevent damage to the product, facility and to eliminate the potential for bodily injury.

Once on the floor level where it will be installed the unit may be rolled on pipe or may be moved by means of a pallet jack. Use of a pallet jack with the Coal Gun™ requires that the boiler be skidded or that the installer has made other provisions to insert a pallet jack under the boiler base without causing damage. The boiler must be placed on a concrete slab or other rigid pad of non-combustible material with sufficient strength to adequately support the boiler, including its contents of water. The boiler should be positioned as closely as possible to the chimney. The smoke pipe must pitch continually upward toward the chimney and be as straight as possible. Level the boiler after it has been positioned.

Before proceeding with installation, inquire with local building officials to ensure that the installation is in compliance with all building, plumbing and electrical codes.

A qualified technician experienced in boiler installations is recommended for the installation of this unit. Wiring on the boiler must be properly grounded.

**WARNING:
BUILDING CODE COMPLIANCE**



The installation of this unit must comply with state and local requirements and must be inspected by the state or local building inspector where required.

NOTE: This unit is not approved nor is it recommended for use in mobile homes.

CLEARANCES REQUIRED FOR SAFETY AND OPERATION

It is important to provide sufficient clearance around the boiler for convenient servicing and cleanout.

The required minimums for Coal Stoker boilers when measured from the exterior of the boiler are 30 inches to the rear (end of boiler with fan assembly), 36 inches to the right side (when facing the front of the boiler), 16 inches on the left, 18 inches from the hopper top and 24 inches to the front (end of boiler with sight tube). For commercial and residential installations, many boiler codes require a minimum of 3 feet of clearance on all sides. It is the customer's responsibility to determine whether the installation complies with local code or insurance company requirements. Refer to Appendix A: Boiler Specification Diagrams for exterior dimensions of the various models.

GENERAL CHIMNEY REQUIREMENTS

One of the most important considerations in installing a wood or coal burning boiler is the type of chimney that will be used. The condition and construction of the chimney is important to provide sufficient draft. The Coal Gun produces its own draft during the on cycle, but the chimney produces the draft during the off cycle. It is necessary to have continual draft, even during the off cycle, in order to move Carbon Monoxide, sulfur, and other gases out of the boiler.

NOTE: For insurance and building code compliance check with your local building inspector and insurance agent.

Natural drafts in a chimney result from two factors. First, draft is created by the aspirating effects of air currents blowing across the top of the chimney. Second, drafts are also produced when the temperature of the flue gases is higher than the atmosphere around the chimney. For this reason a chimney must be kept warm (about 250° F) for proper draft to occur. Please see Draft Control section in this manual for more information.

It is more difficult to maintain sufficient temperature in an exposed chimney, or one that

is very large, than a chimney that is protected from outside temperature extremes.

The chimney must be sufficiently tall (at least 20 feet for masonry chimneys) and should extend at least three feet above the highest part of the roof to prevent downdrafts. The chimney must be leak-free from the standpoint of air entering through cracks or other chimney defects or through loose stovepipe fittings.

If the chimney must go through a combustible wall, be sure to use a metal thimble specially designed for this purpose. The proper way to install a thimble is to cut an oversize hole in the sheetrock about 6 or 7 inches larger than the thimble (refer to Figure 2). However, be sure to follow the manufacturer's directions that come with the thimble. A metal ring shield is used to cover the hole. This way air can circulate and cool the area around the passageway.

Never decrease the cross-sectional area of the stovepipe/chimney because the velocity of the exhaust will increase thus increasing the likelihood of particle discharge in the exhaust.

Technical Aspects of Chimney Performance

A device called a manometer is used in describing the technical performance of a chimney. A manometer is an instrument used for measuring the pressure of liquids and gases. An analog manometer consists of a glass tube filled with a liquid and mounted in front of a measuring scale against which the liquid level can be measured. If a manometer were connected to a leak-free chimney with a leak-free connection, then the draft in the chimney should exert enough pressure (or pull) against the water in the manometer to cause it to move at least 0.04 inches in the tube.

WARNING:
If the draft regulator is set too high it can cause the coal fire to burn out of control.

A barometric damper or draft regulator must be installed in the smoke pipe or flue connector when installing the coal boiler. Manually operated dampers must not be used! The draft regulator should be adjusted to maintain a draft of .04" to .07" during operation particularly when the draft motor is not running. It is important to check the chimney draft when the seasons change to ensure draft settings are correct. Changes may be needed when transitioning from winter heating to summer heating (domestic water heating). The natural draft tendencies will change from one season to the next. It is not uncommon to add a draft inducer in warmer seasons to maintain the recommended .04" to .07" w.c.



**CAUTION:
SUFFOCATION HAZARD**

The airflow through the system and out the chimney means that oxygen is leaving the home and will create an oxygen deficit if this air is not replaced.

The airflow through the system and out the chimney means that oxygen is leaving the home and will create an oxygen deficit if this air is not replaced. There is usually sufficient leakage in older homes, but in well-insulated homes it may be necessary to provide additional outside air into the home.

STOVEPIPE

Use only 22-24 gauge single wall stove pipe in open areas no closer than 18 inches from walls or ceiling. If the stovepipe must be closer than 18 inches from the nearest wall or ceiling, or if it must go through walls, closets, or boxed in areas, then U.L. listed insulated stovepipe must be used. Stovepipe that runs along the outside walls of a building must also be U.L. listed insulated pipe, even if it runs along a non-

combustible outside wall. This requirement is in place in order to prevent cooling of the stovepipe, which in turn cools the rising smoke and causes creosote to form quickly (however, this provision does not apply to the Coal Gun because there is not sufficient gas generated in the exhaust to cause creosote).

PROPER CHIMNEY CONNECTION

The boiler must be connected to a **listed type HT pre-fab. 22 gauge is preferred, but 24 gauge black or blued steel is minimum 24, stainless steel is recommended**). The minimum Flue Diameter for an S260 is 6", an S500 is 8", and an S1000 is 10".

**WARNING:
CODE COMPLIANCE**



Use of aluminum Type B gas vent for solid fuels is unsafe and prohibited by the National Fire Protection Association Code.

Use of aluminum Type B gas vent for solid fuels is unsafe and prohibited by the National Fire Protection Association Code. The recommended method for connecting the boiler to the chimney is to place a T-joint at the top of the vertical section leading from the breach (exhaust) flange. The rear opening must be covered with a cap, which can be removed for cleaning and inspection. A horizontal run must be included, with provision for pipe disassembly, for pipe inspection and removal of any fly ash that accumulates. If the horizontal run to the chimney is inclined, it will encourage any fly ash, which drops in the pipe to fall back into the ash separator.

If a second change of direction is required before entering the chimney a cleanout "T" should be placed at this point also as indicated in Figure 1. Each joint should be secured with three sheet metal screws and sealed with high

temperature sealant capable of withstanding 650° F. Any horizontal pipe should be pitched upward toward the chimney at least ¼" for each foot of horizontal run. Ensure that there is at least 18" clearance between horizontal piping and combustible ceiling. Ensure that the chimney connection pipe extends at least 2" into the chimney, but does not extend so far into the chimney that it blocks airflow. A "T" must always be used where the stovepipe changes directions (rather than elbow) to allow for cleanout. Do NOT connect this unit to a chimney flue serving another appliance.

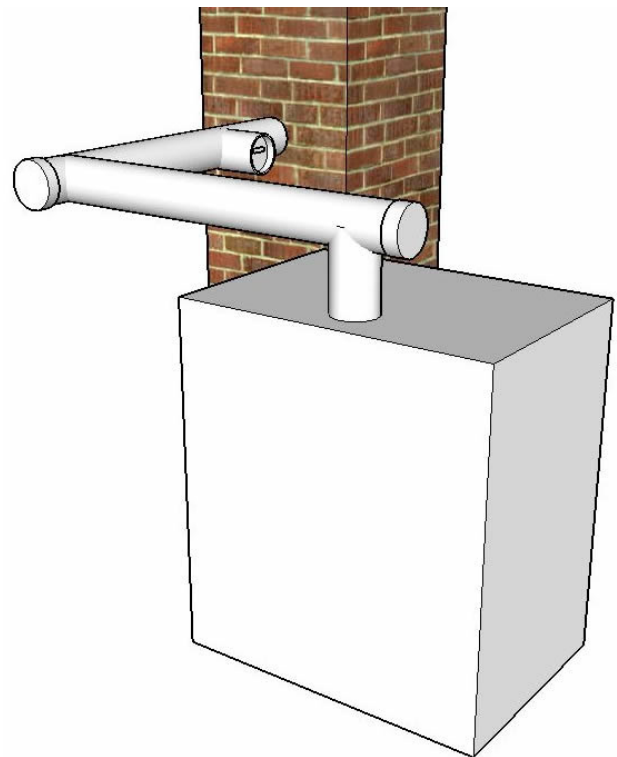

Figure 1: Proper chimney connection

Particular attention should be paid to the point where a flue passes through a wall or ceiling. The pass-thru should always be made with insulated pipe and the proper accessories or use of a thimble that provides a diameter of not less than three times the diameter of the stovepipe. (See Figure 2)

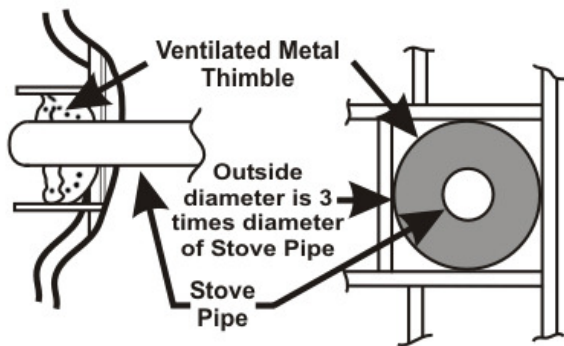

Figure 2: Stove pipe passing through wall

IN CASE OF CHIMNEY FIRE

1. Call the fire department. (In the event the fire is out before they get there, you will want them to inspect the structure and make sure there is no latent damage or hazard.)
2. Shut the boiler down by turning the main power off.
3. If you have a chimney fire, use a chemical flare type fire extinguisher. If you don't have an extinguisher, go to step 4.
4. Using a water hose, wet down the area of the roof surrounding the chimney. Do not wet the chimney itself or try to put water down the flue as it will very likely damage the flue tiles.
5. Contact a chimney professional to inspect your chimney for damages.

IN CASE OF RUNAWAY FIRE

1. Shut the boiler down by disconnecting power off.
2. Be sure the draft inducer is off and/or make sure the barometric damper opens. (Excessive draft can cause a runaway fire.)
3. Maintain continued circulation of boiler water to remove heat from the boiler and if boiler is equipped with a domestic coil run hot water.

COMBUSTION AIR SUPPLY

It is important to make provision for adequate supply of combustion air, either via natural infiltration through a door or window or by ducting outside. If combustion air is ducted from the outside, then install a metal vent pipe of sufficient diameter for the boiler to be used. Contact Alternate Heating Systems if an outside air ducting kit is required.

When the intake is ducted outside, inspect the opening regularly to be sure that it does not become obstructed by debris.

Outside combustion air may be necessary if:

- The solid-fuel-fired appliance does not draw steadily, smell, experiences smoke roll-out, burns poorly, or back-drafts whether or not there is combustion present.
- Any of the above symptoms are alleviated by opening a window slightly on a calm day.
- The house is equipped with a well-sealed vapor barrier and tight fitting windows and/or has any powered devices that exhaust house air.
- There is excessive condensation on windows in the winter.
- A ventilation system is installed in the house.

DRAFT CONTROLS

Where excessive natural draft exists, a barometric damper is required to prevent the boiler from overheating. Do not operate with flue draft exceeding .07in. (6.86Pa). The likelihood of this condition increases with increased chimney height. It is a good idea to include a barometric damper when chimneys are taller than 20 feet. The standard type "M" field control with a "T" is recommended for satisfactory performance. Excessive draft through the boiler will allow an excessive amount of heat from the boiler to escape up the chimney. A draft control will help reduce this loss.

NOTE: The information in the rest of this section is provided by **Field Controls, LLC**, Kinston, North Carolina, 252.522.3031. This information is used with their permission. Some information may not apply to coal burning systems. The information is taken from Field Controls, LLC website at: www.fieldcontrols.com/draftcontrol.php. See the Field Controls website for specific models of draft controls or to place an order.

For proper operation and efficient fuel consumption in oil, gas and/or coal-fired heating appliances, draft must remain relatively constant, and above .04 inches water column, as measured with a manometer. When it is, combustion is more complete, fuels are utilized efficiently and money is saved.

Field Draft Controls maintain consistent draft by counteracting the negative forces caused by changes in temperature and barometric pressure, and the effects of wind. The draft should be checked with a draft meter in the flue pipe two to three feet above the boiler and before the barometric damper.

How Draft Controls Work

NOTE: See diagram below which has been modified for this manual.

Static pressure of the cool air (1) exerts pressure on the outside of the furnace or boiler, the breaching, and stack.

The pressure difference between the room air and heated gas (air) causes products of combustion (2) to flow (draft) through the unit and rise through the breaching and chimney.

Room temperature air (3) enters through the barometric draft control (4) in the precise amount needed to overcome the excess drafts caused by temperature variations, wind fluctuations and barometric pressure changes.

Combustion of fuel is completed and the process is stabilized. The velocity of combustion gases through the heat exchanger is slowed so more heat is extracted. The unit operates more

efficiently, reliably and requires less maintenance.

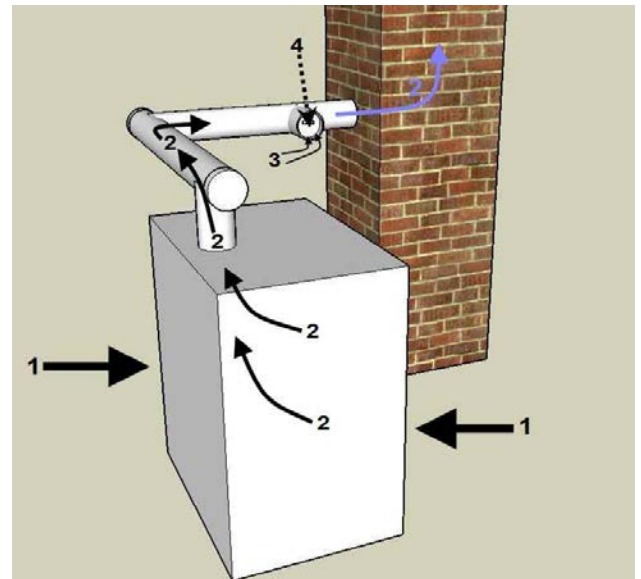

Choosing the Right Size

(Sizing the Control)

Simple rules of thumb to guide size selections:

1. Use a draft control the same size as the flue pipe, that is, a 6" control for a 6" round pipe, a 12" control for a 12" pipe, etc.
2. For intermediate sizes of smoke pipe, use the next larger size draft control to provide ample capacity. It is a simple matter to install a round control on a pipe an inch or so larger or smaller than the control.
3. If the flue pipe or breaching is square, use the round equivalent. For example - on a 14" x 14" breaching use a 14" control. Little flow occurs in the corners of a square pipe so that its capacity is approximately the same as a round pipe of the same diameter.
4. If the breaching is rectangular or oval, compute its cross-sectional area and select a draft control having the same or a greater nominal cross-sectional area. A breaching 14" high x 10" wide would have a cross-sectional area of 140 square inches. From the table, select a 14" control with a cross-sectional area of 154 sq. inches.

5. Where a control larger than 32" is required, use more than one regulator with combined cross-sectional areas equal to or greater than that of the breaching. When chimneys are of an unusual height or if the draft to be maintained is either very high or very low, it is advisable to deviate from the rules of thumb outlined here. Refer to the larger table.

Control Size	Nominal Cross-Sectional Area (Sq. In.)
6"	28
7"	38
8"	50
9"	63
10"	78
12"	113
14"	154
16"	201
18"	255
20"	314
24"	452
28"	616
32"	804

Diameter of Flue or Breeching	If Chimney Height is	Use This Size Control	If Chimney Height is	Use This Size Control	If Chimney Height is	Use this size Control
4	15' or less	4"	16' or more	5"	N/A	N/A
5	15' or less	5"	16' or more	6"	N/A	N/A
6	15' or less	6"	16' or more	7"	N/A	N/A
7	15' or less	7"	16' or more	8"	N/A	N/A
8	15' or less	8"	16' or more	9"	N/A	N/A
9	15' or less	9"	16' – 30'	10"	31' or more	12"
10	20' or less	10"	21' – 40'	12"	41' or more	14"
11	20' or less	12"	21' – 40'	12"	41' or more	14"
12	20' or less	12"	21' – 40'	14"	41' or more	16"
13	22' or less	14"	23' – 45'	16"	46' or more	18"
14	22' or less	14"	23' – 45'	16"	46' or more	18"
15	22' or less	16"	23' – 45'	16"	46' or more	18"
16	30' or less	16"	31' – 50'	18"	51' or more	20"
17	30' or less	18"	31' – 50'	20"	51' or more	20"
18	30' or less	18"	31' – 50'	20"	51' or more	20"
19	30' or less	20"	31' – 50'	20"	51' or more	24"
20	30' or less	20"	31' – 50'	20"	51' or more	24"
21	30' or less	20"	31' – 50'	24"	51' or more	24"
22	30' or less	24"	31' – 50'	24"	51' or more	24"
23	35' or less	24"	36' – 60'	24"	61' or more	28"
24	35' or less	24"	36' – 60'	24"	61' or more	28"
25	35' or less	28"	36' – 60'	28"	61' or more	28"
26	40' or less	28"	41' – 70'	28"	71' or more	28"
27	40' or less	28"	41' – 70'	28"	71' – 100'	28"
28	50' or less	28"	51' – 100'	32"	100' or more	32"
29	50' or less	28"	51' – 100'	32"	100' or more	32"
30	50' or less	32"	51' – 100'	32"	100' or more	32"
31	50' or less	32"	51' – 100'	32"	100' or more	Two 24"
32	50' or less	32"	51' – 100'	32"	100' or more	One 24" One 28"
33	50' or less	32"	51' – 100'	One 32" One 20"	100' or more	One 32" One 24"
34	50' or less	32"	51' – 100'	One 32" One 24"	100' or more	One 32" One 24"

BOILER PIPING FOR HYDRONIC SYSTEMS

Normal operating temperature for the Coal Gun is 180° F. This allows for optimum operation and less fly ash accumulation on heat exchange surfaces. Water returning to the boiler from zones should be about 160° F, and at no time (after initial startup) should be lower than 150° F.

Note: Hydronic and steam distribution and system design are ultimately the responsibility of the customer or installer.

Due to the design requirements of the various Coal Gun™ models, the tapings are not always in the same location on each boiler model. Appendix A: Boiler Specification Diagrams provides detailed information on how each model should be connected. The washout plugs in the bottom of the unit are a requirement of the ASME boiler code and must be closed before filling the unit with water.

Note: Be sure to close all ports in the unit before filling the unit with water.

A boiler drain should be inserted in the tapping on the opposite side of the boiler from the tapping used for the return. Optionally, a “T” and short nipple could be attached to the return tapping for the location of the boiler drain.

Piping the Boiler in Parallel with another Boiler

The Coal Gun™ may be connected to a heating system supplied by one or more boilers that are already in place. There are many possible configurations that allow for an existing boiler to function as a backup to the Coal Gun™. For sample illustrations of multiple boiler configurations, see Appendix I.

A minimum of 1” diameter pipe should be used for this connection on model S130. In any event, the pipe size must be determined by

taking into account the distance involved and flow required.

WHEN BOILER IS ADDED TO AN EXISTING SYSTEM

Operate the (Oil, Gas, Electric) Boiler Periodically to ensure it will operate satisfactorily when needed.

Do not relocate or bypass any of the safety controls in the original boiler installation.

Operate the (*gas, oil, electric*) boiler periodically to ensure that it will operate satisfactorily when needed.

Do not relocate or bypass any of the safety controls in the original (*gas, oil, electric*) boiler installation.

The operation of the *gas* boiler must be verified for acceptable operation before and after installation of the add-on appliance by a gas fitter who is recognized by the regulatory authority.

Do not connect to any chimney or vent serving a gas appliance.

The installation should comply with requirements of CAN/CSA-B365, and changes to the installation should comply with CSA B139 (for oil-fired), C22.1 (for electric), or CAN/CGA-B149.1 or CAN/CGA-B149.2 (for gas-fired).

Pressure Relief Valve

The pressure relief valve is factory installed. A length of copper pipe must be connected to the pressure relief valve continuing to a point 6” from the floor. Extending the pipe to the floor is a requirement of building codes. It reduces the likelihood that a release of boiler pressure would scald anyone standing near the boiler.

If the Coal Gun™ is installed as the primary boiler it is necessary to provide for water supply using a pressure regulating valve and backflow prevention valve in the feed water line.

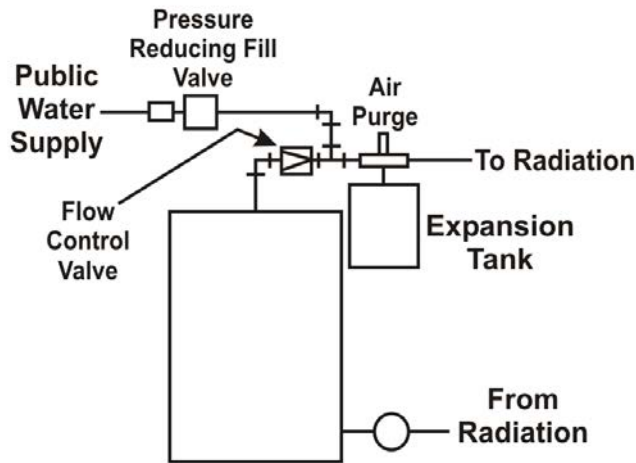

Figure 3: Pressure regulating valve and backflow prevention valve configuration

CAUTION



It is very important to provide adequate expansion tank capacity based on the total volume of water in the system, particularly when the Coal Gun™ is added to an existing boiler.

It is very important to provide adequate expansion tank capacity based on the total volume of water in the system. This is particularly true if the Coal Gun™ is added to an existing boiler. Check the chart to determine the water capacity of the Coal Gun™ installed. The expansion tank or air cushion tank installed originally may not be adequate for the additional volume of the Coal Gun™.

IMPORTANT



Some states require that all hydronic heating systems have a low-water cut-off control.

Some states require that all hydronic heating systems have a low-water cut-off control. In cases where this control is required it should be located in a “T” placed in the supply riser just

above the tapping in the boiler. The S500 and S1000 units are supplied with a low water cut-off from the factory since the ASME code requires that any heating boiler with a calculated heat transfer capacity of 400,000 BTUH or greater must be so equipped. On the S500 and S1000 the low water control should be located in tapping “FF” which is to the side of the 4” domestic coil tapping.

BOILER CONDITIONER / SEALANT

AHS provides two bottles of Boiler Conditioner/Sealant with the purchase of your boiler. When filling your boiler with water for the first time, mix content of each bottle with 2 gallons of warm water. Pour into boiler opening. Replace plug. An MSDS is available upon request.

BOILER PIPING AND CONTROLS FOR STEAM SYSTEMS

All Coal Gun™ models are available with steam tappings and controls upon special order. When installing a steam boiler, be sure that the installation conforms to all state and local codes.

All steam boilers will be supplied with a low water cut-off, which fits into a special tapping on the rear of a Coal Gun steam boiler. This control must never be hot wired or disconnected since it prevents the boiler from firing should the water level drop below the safe operating level.

A water level gauge glass is also provided to give a visual indicator of the level of water in the boiler. An automatic water feeder (mechanical type) or combination water feeder/low water control such as a McDonnell-Miller model 47-2 is required to ensure that the proper water level is maintained. Some states or cities require two low-water control devices in series. The two controls described above will meet this requirement.

CAUTION



It is very important that a steam boiler be properly leveled so that the water feeder and low water cutoff controls function properly. Connecting multiple steam boilers requires further special attention and must be performed by a trained professional.

It is critical in steam applications to take into account the BTU rating of the radiators in the system. If the boiler cannot meet this capacity, there will be areas that do not receive heat.

Steam boilers also have a different wiring sequence, so the proper wiring diagram must be consulted (see Appendix A: Boiler Specification Diagrams).

FORCED HOT AIR SYSTEMS (WATER TO AIR COIL IN DUCT)

The Coal Gun™ boiler may be easily adapted to any forced hot air heating system by installing a heat exchange coil in the supply duct. The size and type of coil or heat exchanger required may be established after several factors are determined. These factors include: the heat output required (BTUH), the capacity of the existing fan blower (CFM) and the size of the duct or plenum where the coil will be installed. Sizing of the air coil will be the responsibility of customer and/or installer.

The coil creates increased resistance to air flow, so this factor must be considered when determining the final airflow. Design water temperature is usually 180° F, and a desirable output air temperature is 115° - 125° F. The coil is connected in the same manner as in other types of radiation heating equipment. The thermostat should be wired to both the fan blower and the circulator pump.

If a hole was cut in existing ducting to install the coil, the opening should be closed tightly with a metal cover and sealed with duct tape.

DOMESTIC HOT WATER COIL PIPING

The Coal Gun™ may be fitted with a domestic hot water coil, which threads into a 4" tapping in the boiler. Multiple coils can be installed into larger boilers, the total number dependent on the size of the boiler and the number of fittings made available at time of manufacture. There are three methods for plumbing the domestic coil. One way is to connect the coil in series with an existing hot water heater.

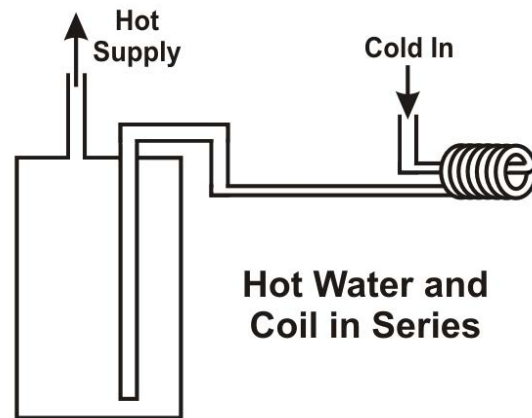

Figure 4: Plumbing – Coil in Series

A second method of plumbing the domestic coil is to connect the coil in parallel with an existing water heater so that the conventional water heater may be used when the Coal Gun™ is not being fired (for example in the summer). The diagram below indicates how this can be done.

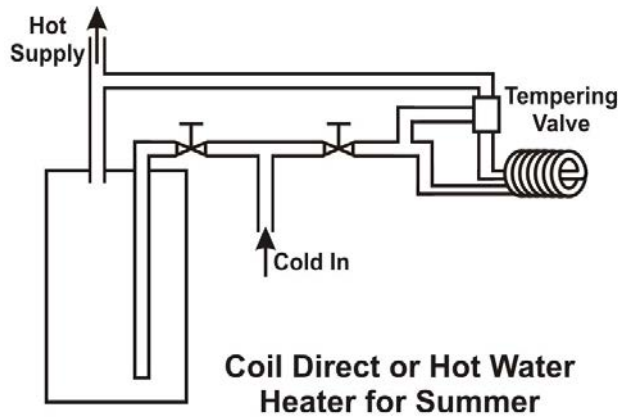



Figure 5: Plumbing – Coil in Parallel

CAUTION: BURN DANGER!



In installations where the coil discharges directly into the hot water distribution system a tempering valve must be included to limit the temperature of the water at the faucet to a safe level.

tempering valve or temperature controller on the supply side of the storage tank/water heater to prevent super-heated water from reaching the domestic hot water tank and, ultimately, the faucets (see Figure 7).

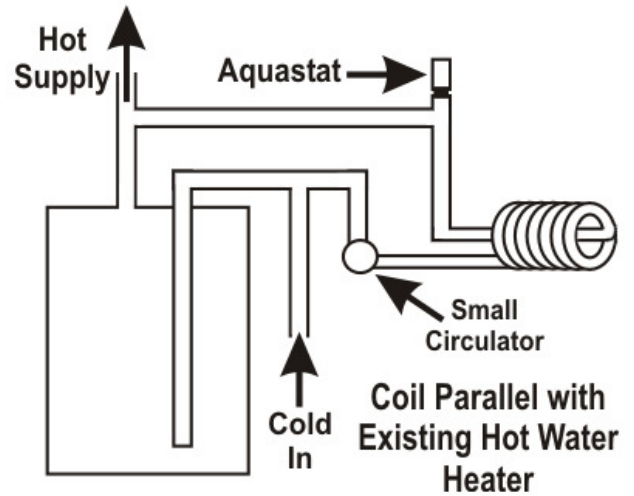

Figure 7: Plumbing – Coil with circulator

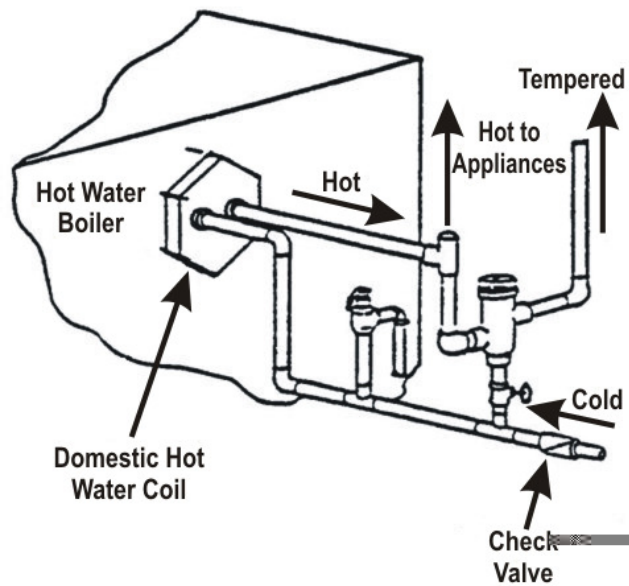

Figure 6: Tempering valve

The third method of plumbing the domestic coil uses a small pump to circulate water continuously between the coil and existing hot water heater. It is also necessary to include a

ILLUSTRATED INSTRUCTIONS FOR INSTALLING COAL HOPPER

Step 1: Disconnect all power to the boiler.

Step 2: Loosen hopper collar screws until they are flush with the inside of the hopper collar.



Step 3: Insert hopper tube into the hopper collar and tighten screws until snug. You may wish to make sure that the hopper is level or adjust to your preference.



Step 4: Feed the wires for hopper temperature sensor into the empty junction box on the side of the hopper. Insert green ground wire into the grounding block and tighten. Attach blue and yellow wires to sensor.



Step 5: Tuck all wiring into the box and replace cover.



Step 6: Connect/reconnect power.

ELECTRICAL CONNECTIONS IN THE COAL GUN™

All Coal Guns are pre wired to maintain boiler water temperature at approximately 180° F.

S130/S260

The S130 and S260 Coal Guns require a dedicated power circuit of 120 volts, 15 ampere. Power connections are in the large enclosure for that control.

S500/S1000

The S500 and S1000 Coal Gun normally require a dedicated power circuit of 230 volts, 20 amperes, single phase. Other power options can be arranged at the time of ordering the boiler. Power connections for the S500 and S1000 are at the appropriate terminals in the main control enclosure.

CONTROLS

Coal Guns for hydronic heating have no provision for control wiring connections to building thermostats. As stated previously, the boilers are designed and wired to maintain water temperature. The control scheme for Coal Gun boilers requires that building thermostats control distribution of the hot water, usually by circulator pumps, zone valves, or both. Hydronic Coal Guns are supplied with dual aquastats. The R-W terminals on the dual aquastat may be used to control a circulator for high water temperature over-ride situations, sometimes known as a “dump zone.” If these terminals are used to directly power a zone, the maximum current draw is 3 amps.

Control Settings

The Coal Gun is provided with a high limit control, a combination operating limit control, which activates the draft fan, a dump zone control, and an electronic ash temperature monitoring control. It is very important to

follow these setting guidelines for proper operation of the boiler.

The operating limit is designed to maintain boiler temperature under normal operating conditions by turning the draft fan on and off. The range for this control is from 150° F to 180° F. The normal factory setting is 180° F.

The dump zone temperature control is designed to operate one or more heat zones to prevent high boiler temperatures from occurring during low load conditions. This setting should be set 20° F above the operating limit setting with a maximum setting of 200° F. Also refer to the dump zone wiring instructions for specific use applications. See Appendix H for example dump zone wiring applications.

The ash temperature monitoring control incorporates a digital process controller for operating the coal grate motor based on ash temperature in the grate area. It maintains active monitoring of grate temperature. In **Mode 1** the controller may cycle the grates while the boiler fan operates or not. In **Mode 2** the controller will only operate when the draft fan is running. This control also reduces the likelihood of unburned coal being dumped into the ash pan.

This control is factory set to 140° F and should not be adjusted to more than 10° F higher or lower than the factory setting for best operation (refer to Appendix G for instructions). When reading the digital readout, *PV* refers to the *process variable*, or actual ash temperature reading. *SV* refers to the *set point variable*, or the temperature set point of the control. Based on factory settings, when the temperature of the ash drops to 5° F below the reading indicated at *SV* the grates will cycle on, operating until ash temperature climbs to the *SV* value.

The grate interval timer allows the grate motor run time to be adjustable. This is made up of two Schneider timers located in the control box. Adjusting the run time of the grate motor will enable the boiler to be fine tuned and allow for a better burn percentage. Keep in mind that most

Coal gun boilers will not need adjusted. Your boiler is already setup for most situations and adjusting the timer is primarily to adapt the boiler to conditions like very low demand and very high demand.

The **on timer** and the **off timer** consist of a white dial and a black knob. The white dial on the timer allows you to select the scale (i.e.: seconds, minutes, and hours.). The black knob selects the duration or a percentage of the scale selected by the white dial. For example if the white dial is set to the scale 1-10min and the black knob is set at 5 then it will time out around five minutes. A stop watch must be used to be sure that the change is made accurately. The **off timer** should always be set equal to or higher than the **on timer**. Usually setting the **off timer** 20 to 30 seconds longer than the **on timer** is appropriate.

S500/S1000

If the timers were adjusted incorrectly and need to be reset follow these parameters.

The **factory setting** for the **on timer** is as follows: The white dial is set at 1-10min and the black knob is set at 9 ½.

The **factory setting** for the **off timer** is as follows: The white dial is set at 1-10min and the black dial is set at 10.

When adjusting the timer only do so when you can observe the boilers operation every hour or two for eight hours. To ensure the grate operation is not changed too much too quick each adjustment should not change the grate operation more than 30 seconds each cycle. All adjustments must be checked with a stop watch to ensure that it was made properly. Always allow forty eight hours for the boiler to acclimate to the adjustment made before making another 30 second adjustment. **CAUTION** if the timer is adjusted to keep the grate motor off too long, it will cause the fire to travel towards the hopper triggering the heat sensor which will turn off the boiler. The same can happen if the grate switch is not turned on.

The grate can be set up to run in two modes. In Mode 1, the grate will run when the ash temperature controller and the interval timers allow it to run. In Mode 2, the grate motor will run as it does in mode 1 but in mode 2 the draft fan must also be running. There is a more of a chance of creating clinkers when set in Mode 2. Clinkers that the unit is able to remove on its own do not cause a problem. To find out more on clinkers go to the trouble shooting guide. Typically mode 1 will work when you have higher demand (winter), and mode 2 will work in lower demand (early fall/late spring).

The S500/S1000 Coal gun grate controls are factory set for **High demand** output.

If the coal ash has a high percentage of unburned coal reducing the run time of the grate may help. It is not advisable to make adjustments unless the problem is persistent. To adjust the run time of the grate, turn down the set value of the **on timer** 30 seconds with the black knob. Allow the change to acclimate for forty eight hours. If a large percentage of the coal ash is still unburned after forty eight hours, repeat the step and turn down the set value of the **on timer** another 30 seconds with the black knob. When demand on the boiler increases inspect the boiler twice daily to ensure the grate is removing enough as to allow the boiler to keep up with demand and to also make sure that the fire is not burning into the hopper tube or hopper. There is a hopper safety switch that inhibits the boiler from running if it is activated.

Don't make adjustments to the grate interval timer that would inhibit the grate motor from running less than 30 seconds every 10 minutes.

The power switches are located on the front of the control panel. The "Main" switch will shut off all power to the unit. The "Grate" switch will shut down the grate motor function.



WARNING:

Fuses must be replaced with the same amperage and fuse type as supplied with the unit!

Thermostat Connection

Hydronic Coal Guns do not require a connection to a building thermostat for operational purposes. The boiler water temperature is controlled by the aquastats.

Steam

Steam Coal Guns require a connection to a building thermostat. The switching relay on the Steam Coal Gun has two T terminals to which a low voltage thermostat must be connected.

BOILER DUMP ZONE APPLICATIONS

Unlike oil or gas fired boilers, solid fuel boilers will still produce some additional heat after the call for heat has ended. This will cause the boiler temperature to rise if no zones are calling for heat. It is possible to see temperature rise 30° F or more under a low or no load condition. This will take place until the boiler's radiation losses match the heat gain. It is recommended that a dump zone be connected to dissipate this excess heat to one or more zones in the system. Setting the operating limit no higher than 180° F allows for the heat rise to occur without exceeding the recommended maximum temperatures.

The dump zone aquastat can be used to activate a zone valve or circulator as a dry contact switch. A common setting for dump zone actuation would be 210° F, with the high limit set point adjusted to 10° - 20° lower. When this high limit is exceeded, and temperature reaches the dump zone limit, one or more zones will be energized and heat distributed until temperatures

fall sufficiently. See Appendix H for a variety of dump zone wiring examples.

If the dump zone is connected to provide heat to a domestic hot water tank or heat exchanger, a mixing valve must be installed on the potable system supply to prevent an unsafe condition of overheating the domestic hot water. The mixing valve outlet should be set no higher than 125° F for potable use (for this type of dump zone, see Appendix H, Example 5).

Non Powered Dump Zone

A non powered dump zone is required. This is to provide a way to dump boiler heat in the event that power loss occurs. This hot-water circulation loop shall be able to dissipate at least 10% of the estimated rated heat output of the solid-fuel boiler when circulation is reduced because of an electrical power failure. The loop can only be made inoperative by a deliberate manual action. The design parameters for sizing shall be a pipe size equal to or greater than 3/4 inch (18 mm), room temperature of 65°F (18°C), and mean water temperature of 180°F (82°C). The loop shall be positioned above the boiler, with features that promote natural thermal circulation of the water. The piping be such that

excessive pressure will not be developed in any portion of the boiler or system. Larger diameters may be needed as boiler size increases. Figure 9 shows an application example of how this is accomplished.

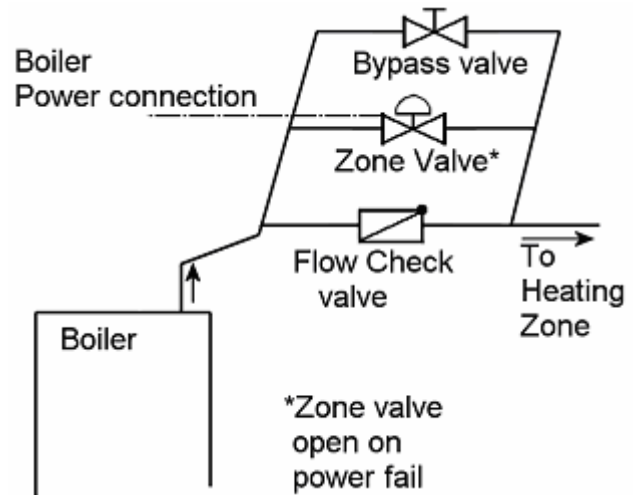

Figure 9: Non-Powered Dump Zone

This arrangement will allow a gravity flow of heat release in the event of a power failure. For other dump zone applications, see Appendix H.

OPERATING INFORMATION

Please read this manual before operating the boiler. Important requirements and instructions must be followed for safety and satisfactory operation of the boiler. When operating the unit you must keep the doors closed and maintain the seals in good condition. **All covers or guards must be in place at all times, except for maintenance or service.**

The quality and burning characteristics of coal vary widely so it is important to use the type of coal for which the Coal Gun™ was designed. Best results will be obtained using pea-size anthracite having a high ash fusion temperature. All bituminous or lignite types of coal are unacceptable for use in the Coal Gun.

When starting a fire, it is advantageous for both the system and the house to be cold. This allows the Coal Gun to establish a good burn before reaching maximum temperature, after which the draft induction fan that powers combustion will shut down. Before starting the fire, turn off the grate switch and fill the hopper full of pea or buckwheat coal.

At this point, when you look into the coal pot through the sight hole cover, you will see coal lying close to the opening. Insert several fire starters (such as Rutland Safe Lite) so that they are nearly covered by the coal. Light the starters. When they are burning and unlikely to be extinguished by the draft provided by the draft-inducing fan, turn the boiler on. The draft-inducing fan will be heard running. Make sure that the sight hole cover is pulled up against the seat (see Operation of Sight Hole Cover below). Allow the Coal Gun™ to run for two to three hours (this allows the coal in the coal pot to burn). After this time turn the grate on. The first time the grates cycle, there will be unburned coal in the ash tub. This may be placed back into the hopper.

The Coal Gun™ requires an ash tub, which can be obtained from Alternate Heating Systems LLC. or your local hardware store.

WARNING:



Be sure the boiler vessel is full of water and pressurized before starting a fire. Never attempt to add water to a hot boiler if found to be only partially full. Allow the unit to cool before adding water to the boiler. Failure to do so could result in death or severe injury along with damage to boiler and surrounding property.

LIGHTING THE COAL GUN™

CAUTION



NEVER use chemicals or flammable liquids to start the fire. DO NOT burn garbage, other types of coal or any other fuel not approved for this unit

The use of emergency power from a backup generator is necessary for operating the Coal Gun™ during a power failure. Without backup power, the fire in the Coal Gun will gradually go out. The boiler will be unable to supply heat without backup power.

Warning- Risk of fire:

- Do not operate with fuel hopper lid off or ash removal doors open.
- Do not store fuel or other combustible material within marked installation clearances.
- Inspect and clean flues and chimney regular.

Caution

- Unit is HOT while in operation.
- Do not touch during operation.
- Do not operate without the hopper lid, site tube cover, or ash pan and ash doors in place.
- Boiler will have multiple hot surfaces.
- Keep children away.

OPERATION OF SIGHT HOLE COVER

The proper operation of the sight hole cover is crucial both in the off cycle and during fan operation. The cover position during the off cycle must be open allowing a gap of 3/8" or more between it and cover seat. This allows air to by-pass the fire bed, preventing over heating of unit during the off cycle.



Sight Tube Cover in Open Position

When the fan is running, and unit is full of coal, the sight hole cover must be drawn against the cover seat automatically and held there during the time the fan runs. This is necessary to force combustion air through the fire bed rather than across the top.



Sight Tube Cover in Closed Position

Chimney draft conditions and fuel conditions both affect the balance necessary to achieve the sight hole cover function. Adjustment of the nut and spring tension holding the sight hole cover is often necessary after installation. When this adjustment has been made, be sure to reattach the shield over the site tube. In the above photos, the shield has been removed so that the sight tube cover may be observed.

CAUTION



The sight tube settings should not be altered for increased firing for any reason.

SHUTTING DOWN THE COAL GUN

When the heating season has ended, or in anticipation of a long period with no demand for heat, it will be desirable to allow the fire to go out in the Coal Gun™. Unlike non-solid fuel boilers, the fire in the Coal Gun will not go out instantly; it will necessarily have to “coast” to a stop.

The procedure for shutdown is to turn off the boiler “Main” switch and to simply wait until

the fire goes out. It will be important during this time to maintain the sight tube cover in the open position, as seen in Figure 10. Without power to the draft-inducing fan, the boiler cannot actively fire and will over a period of days lose the fire. When the fire has gone out and the boiler has cooled sufficiently, the cleanout procedure described in Appendix D may be performed. This procedure is generally conducted at the end of each heating season.

When shutting down the boiler to clean the unit, simply stop adding coal to the hopper. Allow the remainder of the coal to burn out before turning off the main switch. Keep in mind the boiler draft motor will continue to run until the main switch is turned off.

AUTOMATIC FUEL DELIVERY SYSTEMS

The Coal Gun has two methods of fuel delivery; a hopper, or an auger and hopper combination. When the hopper alone is used, the Coal Gun can run unattended for up to seven days. When used alone, the hopper must be filled by hand with a scoop or bucket. After the hopper is filled the lid **MUST** be placed on the hopper for combustion to occur properly. Coal is then fed by gravity from the hopper into the burn chamber.

WARNING:



The hopper lid must be on at all times during operation of the unit. Failure to keep the hopper covered could result in uncontrolled air entering the fire bed and extreme overheating.

If an auger is used to feed coal, the hopper and lid are still also used except the lid is designed with a hole to allow the coal to fall from the auger through the lid and into the hopper. The auger must be equipped with a snout, and the

snout of the auger must be securely attached to the sealed hopper lid. The lid must be oriented on the hopper so that the coal falls from the auger snout into the hopper on the opposite side of the hopper from the coal-level sensor as seen in Figure 12.

BASIC AUGER OPERATION

These instructions apply only to Coal Gun™ systems supplied with auger feed:

The automatic auger switch has 3 positions:

Off – disables auger function (middle position)

Manual – This position energizes the auger at all times (for maintenance only)

Automatic – Use this position to operate the auger in automatic feed mode. The auger will be controlled by the hopper level sensor and will maintain the level of coal in the hopper.

The level sensor responds to the proximity of coal. As the hopper empties, coal will fall away from the sensor. After a programmed delay, normally one minute, the sensor will turn on the auger. The sensor will turn off the auger once a sufficient amount of coal makes contact with it.

Auger must be set up to drop coal as close to the sensor as the lid will allow. (10”)

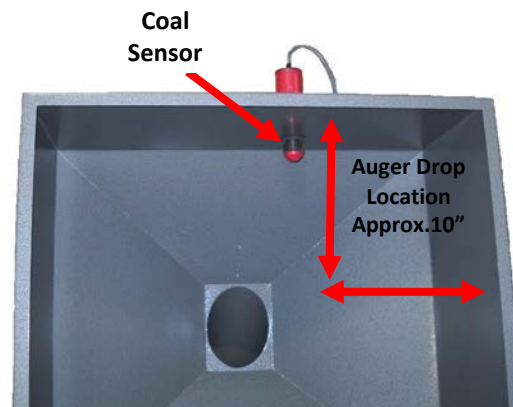

Figure 12

AUGER ASSEMBLY

The auger should be mounted to and connected to the hopper lid. It must also be supported by suspension from the ceiling or overhead structural framing so that the weight of the auger does not rest on the hopper lid.

WARNING:



If the hopper is empty while the unit is burning, add only small amounts of coal for the first half hour in order to prevent ignition of flammable gases in the flue pipe area.

THERMO ASH-MONITORING GRATE CONTROL OPERATION

Ash that contains fuel that is not fully combusted will be a higher temperature than ash coming from thoroughly combusted fuel. The Thermo Ash-Monitoring Control automatically monitors the temperature of the ash leaving the coal pot. This provides a feedback mechanism for grate regulation that reduces the need for post install adjustments. Typically, no adjustment other than the factory adjustment is necessary to have the boiler perform at peak power output throughout the burn season (a minor on-site adjustment may be necessary when the boiler is first installed). With the Thermo Ash Monitoring controlled grate, it is possible for the fire to remain lit for days during low usage periods without having to adjust the grate controls by hand.

If an ash temperature sensor is used, it should be set at 140° for normal operation. During periods of light demand, reducing the setting to 120° will aid in maintaining the proper level of coal in the coal pot. For more information see “Controls” on page 13.

FUEL STORAGE / REMOVAL AND DISPOSAL OF ASHES

BURN ANTHRACITE PEA OR BUCK WHEAT COAL ONLY

Fuel shall not be stored within the appliance installation clearances or within the space required for refueling, ash removal, and other routine maintenance operations. Store fuel in a purpose built storage unit that is adequate for the volume of fuel that you will be handling. The storage unit should keep the fuel dry and should be accessible to clean when empty.

Ashes should be placed in a metal container with a tight fitting lid. The closed container of ashes should be placed on a non-combustible floor or on the ground well away from all combustible materials pending final disposal. If the ashes are disposed of by burial in soil or otherwise locally dispersed, they should be retained in a closed container until all cinders have thoroughly cooled to prevent inadvertently starting a fire.

CONDITIONING OF BOILER WATER

Proper treatment of make-up water and boiler water are necessary to prevent scale or other deposits and corrosion within the boiler. The absence of adequate external and internal treatments can lead to operation upsets or total boiler failure. Where a choice is available, pretreatment external to the boiler is always preferred and more reliable than treatment within the boiler.

Instructions for feed water treatment as prepared by a competent feed water chemist should be followed. Do not experiment with homemade treatment methods or compounds.

Representative samples of feed water and boiler water need to be analyzed frequently to ensure that they are in specification. The following terms and guidelines are to be used in conjunction with the advice of a water treatment specialist.

Ph

The Ph value of your boiler water is a number between zero and fourteen. Values below seven are acidic while values above seven are basic.

The Ph factor is the most important factor influencing scale forming or the corrosive tendencies of boiler water. It should be adjusted to between a minimum of 10.5 and a maximum of 11.0 to prevent acidic corrosion of boiler tubes and plates and to provide for the precipitation of scale forming salts.

Below a Ph of 5.0 the water is acidic enough to dissolve the steel boiler plates. Under these conditions the steel gradually becomes thinner and thinner until it is destroyed. At a Ph between 5 and 9.4 pitting of steel plates will occur at a rate dependent upon the amount of dissolved oxygen in the boiler.

DISSOLVED OXYGEN

Aeration of city water supply is frequently used to remove other noxious gasses, however, efficient aeration results in saturation of the water with oxygen. The majority of corrosion problems are directly related to the quantity of dissolved oxygen in the boiler water.

Elimination of the corrosive effect of dissolved oxygen can be accomplished either directly or chemically.

Direct or mechanical removal of dissolved oxygen is done through the use of a de-aerator. Chemical de-aeration is done through the introduction of specific chemicals in the boiler to react with the oxygen. The dissolved oxygen content should not exceed 0.007 mg/l.

SULFITES

Sodium sulfite is generally used for the chemical removal of dissolved oxygen within the boiler water. To assure the rapid and complete removal of the oxygen entering the boiler feed water system the concentration of sulfite in the boiler must be maintained at a minimum of 120 ppm. (parts per million).

SOLIDS

Solids can be broken up into two categories; suspended and dissolved. Suspended solids are those that can be removed by filtration while dissolved solids are in solution with the water.

The best test for the determination of the solids content of the boiler water is through a conductance test. The conductance value of boiler water varies by the various ionized salts present. The conductance can be used to measure the total dissolved solids in the boiler water and to serve as an accurate means for the control of solids through the use of blow down.

Another test that is sometimes used as a measure of solids is to measure the chloride present in the boiler water. The ratio of chlorides in the boiler water to that of the feed water can be used as a means to determine the amount of blow down required. The chloride test is unsuitable for feed water with low incoming concentrations, and the concentrations in the feed water must be averaged over time for accuracy.

High boiler solids will lead to foaming, priming, surging, and carry over. These conditions may only be overcome by proper daily blow down of the boiler.

ALKALINITY

The alkalinity of boiler water should be sufficiently high enough to protect shell and plates against acidic corrosion, but not so high as to produce carryover. A minimum value for alkalinity for adequate protection is 200 ppm.

High boiler alkalinity (in excess of 700 ppm) should be avoided. Values higher than this can cause the steel to become brittle.

PHOSPHATES

Phosphates are used to react with calcium hardness in the boiler water. In order for this reaction to take place it is important to maintain a Ph at a minimum value of 9.50. It is desirable

to keep the concentration of phosphates in the water to 30-50 ppm to enable the complete reaction of the phosphates with the calcium hardness entering the boiler through the feed water.

HARDNESS

The hardness of water is caused by calcium and magnesium ions. Water hardness will vary greatly throughout the country depending on the source of the water.

In boilers hard water can cause the formation of scale and sludge or mud. The hardness must be

removed in the makeup water to the return system. Total hardness should not exceed 50 ppm.

OILS

Every effort should be made to prevent oils from getting into the boiler water. Oil causes foaming or combines with suspended solids to form a sludge, which can cause the overheating of boiler plates.

If oil does get into the boiler, the boiler should immediately be taken out of service and thoroughly cleaned.

APPENDIX A: BOILER SPECIFICATION DIAGRAMS

S130 - S260 COAL GUN SPECIFICATION DIAGRAM

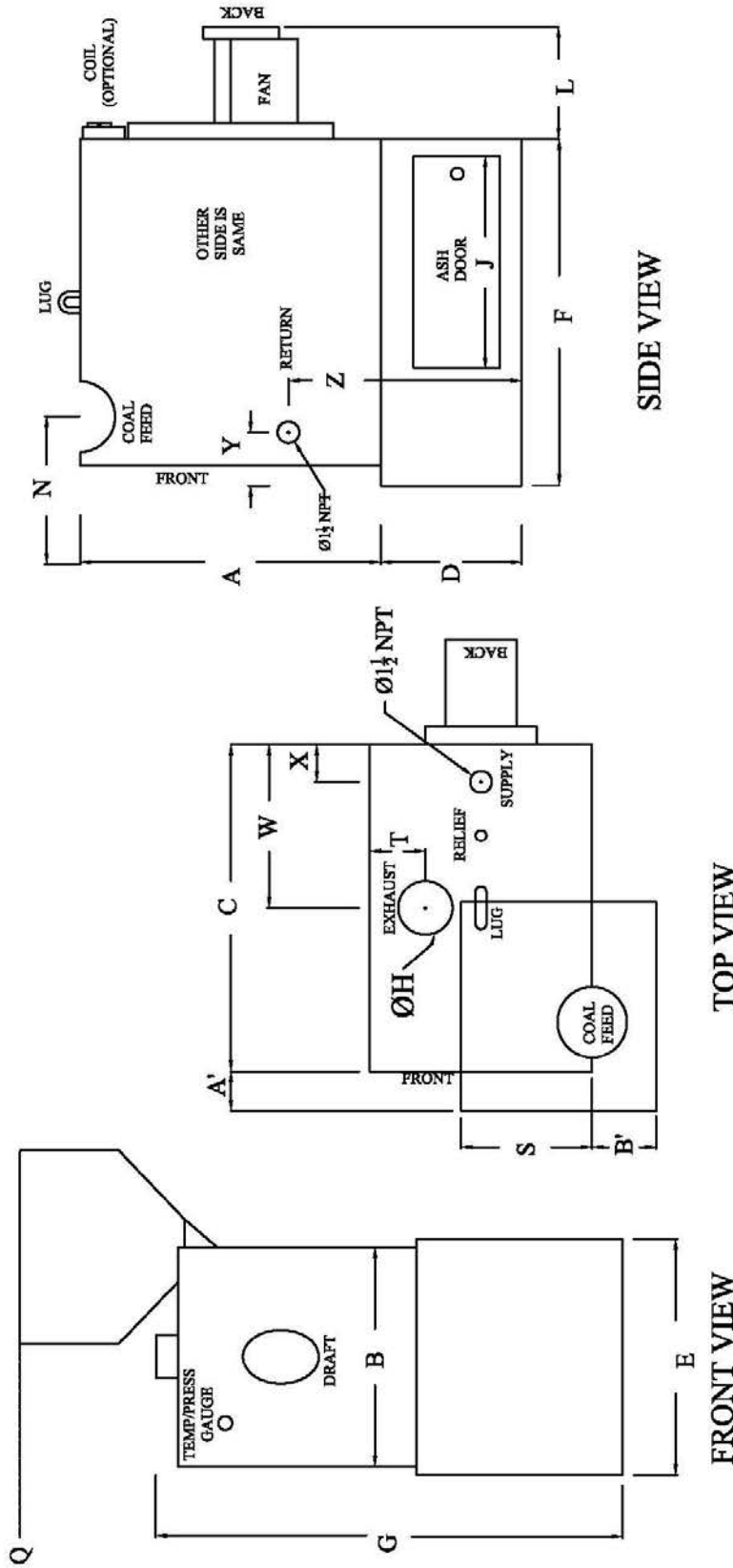

	A	B	C	D	E	F	G	H	J	L	N	O	Q	S	T	W	X	Y	Z	A'	B'
	BOILER HEIGHT	BOILER WIDTH	BOILER LENGTH	BASE HEIGHT	BASE WIDTH	BASE LENGTH	TOTAL HEIGHT	FLUE OPENING	ASH DOOR WIDTH	FAN MOTOR LENGTH	COAL FEED	FAN MOTOR HP	TOTAL HEIGHT	CENTER LINE	EXHAUST LOC	EXHAUST LOC	SUPPLY LOC	RETURN LOC	RETURN HEIGHT	BOILER OVERHANG	BOILER OVERHANG
S130	22	21	31	19	24	33	45	5	23	12	10	1/4	59	10	5	15.5	3.5	5	22	4	13
S260	26	25	45	21	25	48	50	6	23	19	13	1/2	62	12	6	26.5	4	7	22.5	2	12

All dimensions in inches unless otherwise specified. Alternate Heating Systems, LLC. Copyright 2006. Specifications subject to change without notice.

ADDITIONAL SPECIFICATIONS

Pressure Drop

Pressure Drop (Line Loss) within the boiler is less than the pipe rating of the pipe within the boiler, so there is no appreciable pressure drop.

Explanation of GPM Flow

The following are given as examples of gallons per minute water flow required to deliver hot water in order to provide heating of a given number of degrees and at a certain BTU level:

- 500K BTU's at 20 degrees temperature differential requires 50 gallons per minute.
- 250K BTU's at 20 degrees temperature differential requires 25 gallons per minute
- 1M BTU's at 20 degrees temperature differential requires 100 gallons per minute

APPENDIX B: WIRING DIAGRAMS

S130/S260 COAL GUN W/ HYDROLEVEL LWCD and ASH GRATE TEMP CONTROL (UL ONLY)

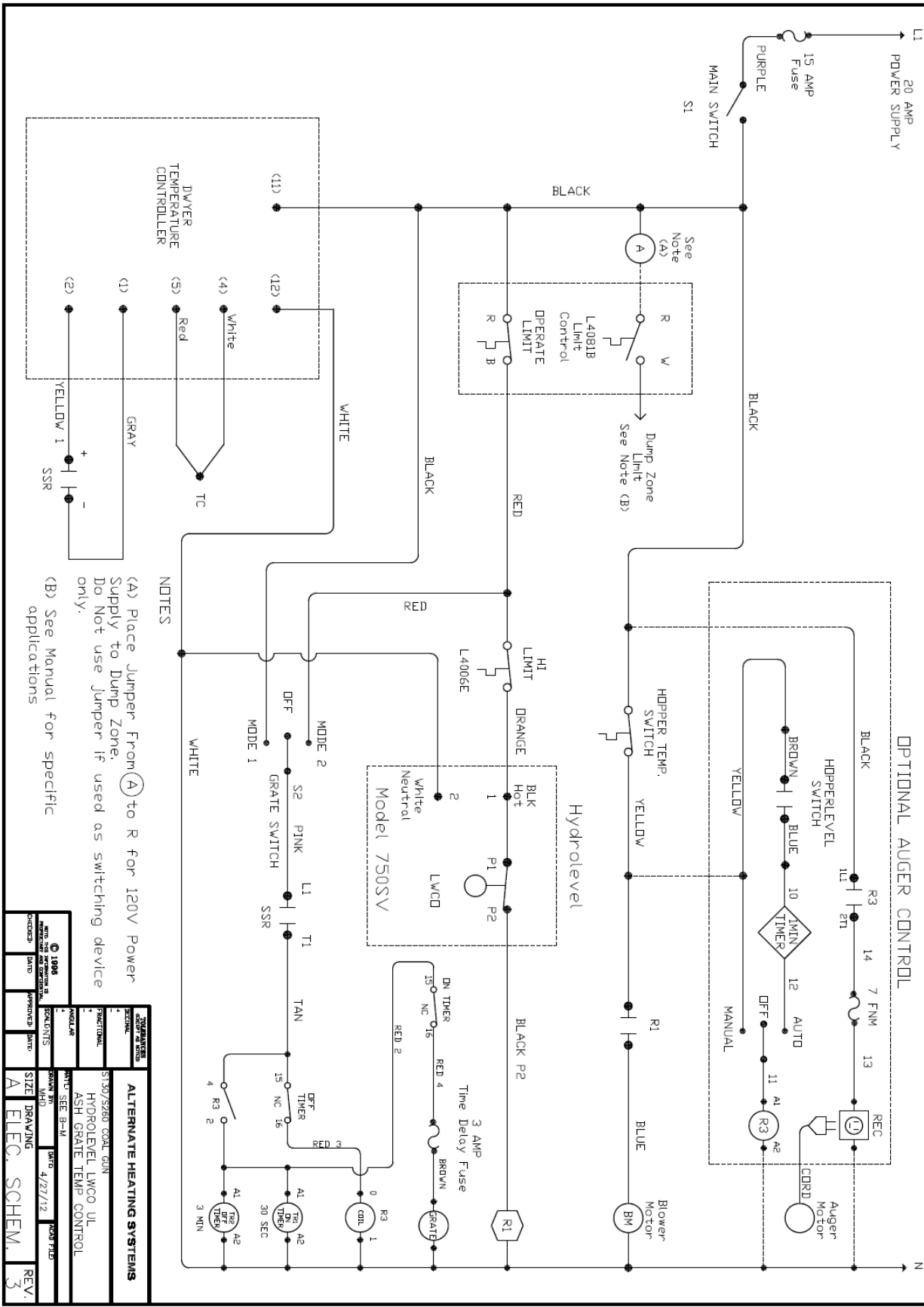

NOTES
 (A) Place Jumper From (A) to R for 120V Power Supply to Dump Zone. Do Not use Jumper if used as switching device only.
 (B) See Manual for specific applications

COMPONENTS		ALTERNATE HEATING SYSTEMS	
DESCRIPTION	QTY	DESCRIPTION	QTY
15 AMP FUSE	1	HYDROLEVEL LWCD UL	1
20 AMP POWER SUPPLY	1	ASH GRATE TEMP CONTROL	1
MAIN SWITCH (S1)	1		
HI LIMIT SWITCH (L4006E)	1		
P1 P2 SWITCH	1		
LWCD	1		
3 AMP FUSE	1		
DN TIMER (RED 4)	1		
30 SEC TIMER	1		
GRATE SWITCH	1		
SSR (T1)	1		
MODE 1 SWITCH	1		
MODE 2 SWITCH	1		
SSR (T2)	1		
TC	1		
YELLOW 1	1		
SSR	1		
HOPPER LEVEL SWITCH	1		
10 MIN TIMER	1		
MANUAL SWITCH	1		
REC	1		
Auger Motor	1		
CORD	1		
BM	1		
Blower Motor	1		

S500-S1000 UL COAL GUN ELECTRICAL SCHEMATIC

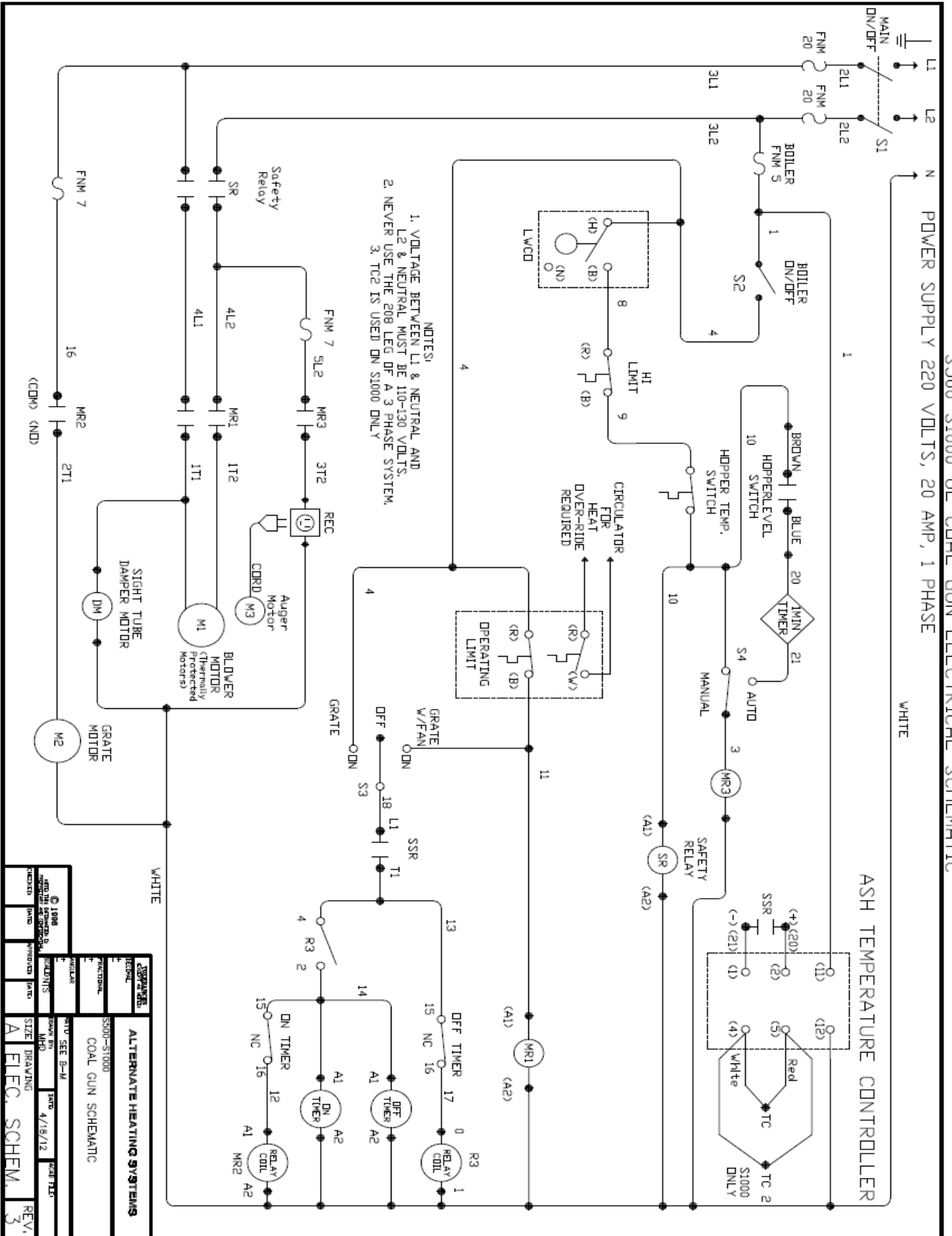

REV. 3	DATE 4/19/12	BY JAL	DESCRIPTION
REV. 2	DATE	BY	DESCRIPTION
REV. 1	DATE	BY	DESCRIPTION
ALTERNATE HEATING SYSTEMS COAL GUN SCHEMATIC S500-S1000 DRAWING SIZE A ELEC. SCHEM.			

APPENDIX C: EXPLODED PARTS DRAWING

Parts Listing

(As Shown in Exploded Parts Diagram)

- 1.Hopper Lid (square lid now used)
- 2.Coal Hopper (square hopper now used)
- 3.Draft Inlet Cover
- 4.Draft Inlet Flap
- 5.Right Insulation Cover
- 6.Grate Base Door
- 7.Grate Assembly
- 8.Thermocouple for Thermo-Controlled Grates
- 9.Grate Motor
- 10.Pitman Block
- 11.N/A
- 12.Pitman Connecting Pin
- 13.N/A
- 14.N/A
- 15.N/A
- 16.N/A
- 17.Domestic Water Coil
- 18.Fan Disk
- 19.Abrasion Shield
- 20.Ceramic Heat Shield
- 21.Fan Motor Mounting Plate
- 22.Fan Motor
- 23.Left Insulation Cover
- 24.Top Insulation Cover (Two Pieces)
- 25.Flue Tube Assembly
- 26.Cyclone Funnel

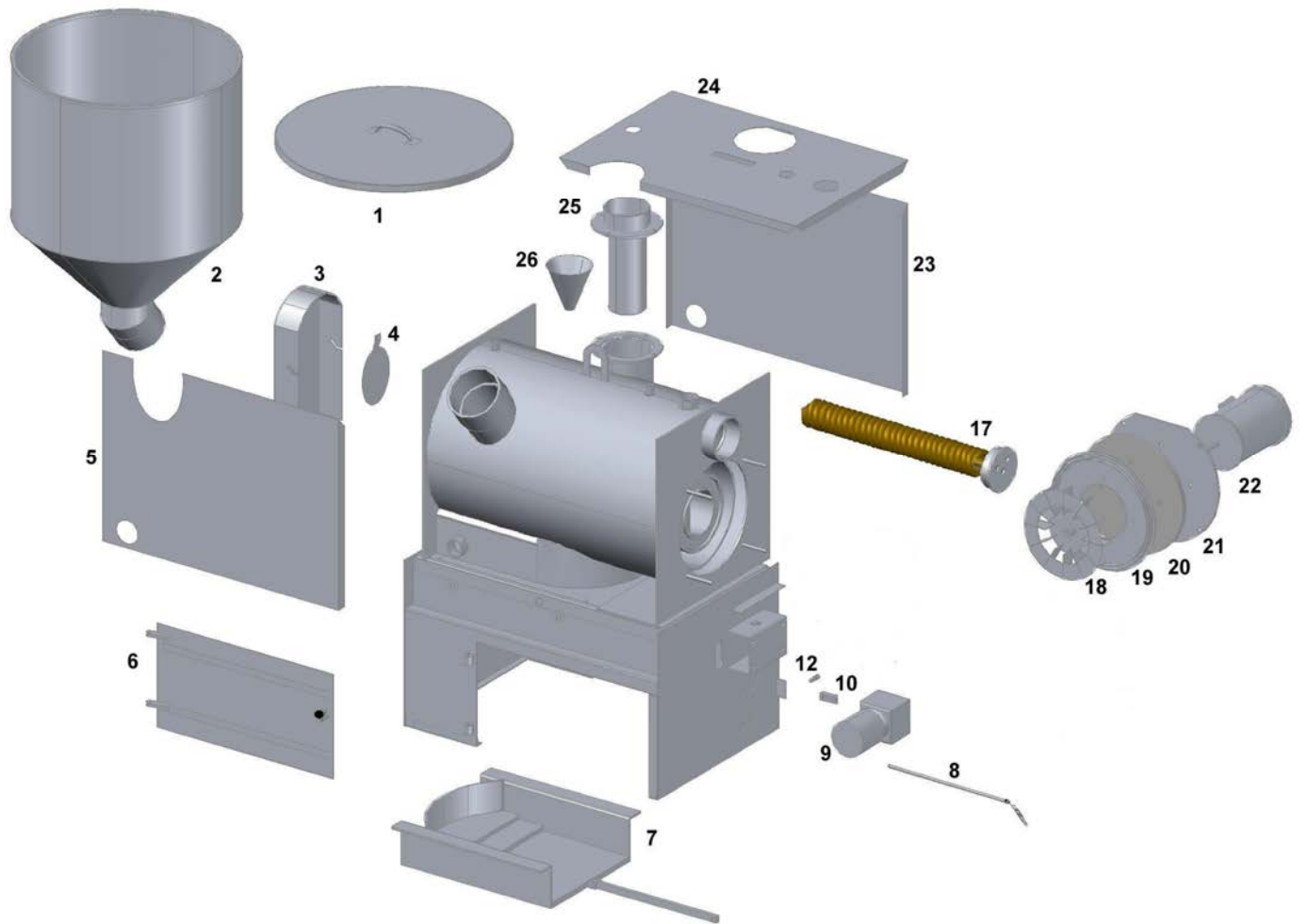

APPENDIX D: MAINTENANCE

The Alternate Heating Systems Coal Gun™ is designed to provide years of reliable service. Nevertheless, it is necessary to provide basic service in order to maintain optimum efficiency and service from your boiler. We recommend that you have your authorized Alternate Heating Systems dealer provide the seasonal preventative maintenance service. If you decide to provide your own maintenance, the instructions provided here are to be used as a guide. Routine maintenance should be performed every three months on units in continuous operation and at least once each heating season on residential installations.

Before the boiler is serviced, shut off power to the boiler. The coal fire must be completely out. If the boiler has been actively firing, it may take days for the fire to go out completely. Make sure the coal pot, boiler and ash grate are cool.

CLEANING HEAT EXCHANGER AND VENTING SYSTEM

It will be necessary to remove the fan assembly before cleaning the heat exchanger. Removing this assembly is described in a subsequent section of this manual. Caution cleaning of the heat exchanger, flue pipe, chimney and draft inducer if used, is especially important at the end of the heating season to minimize corrosion during the summer months caused by accumulated ash.

Brush and clean the heat exchanger area and vacuum all material. Remove the smoke pipe from the boiler to the chimney and clean out all debris with a brush. Clean the chimney if necessary. **Check daily for build up until experience shows how often cleaning is necessary.** Remove the bolts on the boiler flue outlet and remove the cyclone tube. Clean all

deposits from the tube, flue and openings in the heat exchanger tube. Inspect and replace any damaged gaskets (*a fiberglass rope gasket is used for the fan assembly*) and check the ceramic heat shield, replacing as necessary. Check the fan assembly belt on belt-driven units, adjust tension and alignment as needed, replace if worn or damaged.

Reinstall fan assembly, cyclone tube, and smoke pipe. Tighten the fan assembly bolts opposite from each other, using even torque as you work around the assembly. Refasten and seal the smoke pipe.

CLEANING COAL POT, FEED TUBE AND GRATE

Remove and clean the ash pan. Remove remaining coal from the hopper, coal pot and grate. Examine all areas for damage and clean as needed. Remove grate linkage arm and manually move grate back and forth to check bearing condition. Reassemble grate arm. Lubricate grate chain with chain oil and check sprockets for wear (on commercial units).

Other routine maintenance items include:

Drive belts and roller chains should be inspected and tightened if necessary. To adjust drive belt tension and alignment, loosen motor mount bolts (belt drive units only) and slide motor so as to affect proper tension and alignment. To adjust roller chain tension on grate system (on commercial units), loosen grate motor mount bolts and slide grate motor so as to affect proper chain tension. This will be accomplished when there is about ¼ inch of play in the roller chain.

The fan shaft bearings on belt drive units should be lubricated with a small amount of

high temperature service grease such as Drydene Prypoplex EB 2, or the equivalent.

❑ Several drops of oil should be placed on the pitman shaft bearing blocks.

The chimney connector and chimney should be inspected at least monthly during the heating season to determine if ash buildup has occurred. If ash accumulates on the walls of the stovepipe and chimney, it restricts the flow of air and reduces draft.

On units that have a shaft drive fan, the motor bearing will need to be replaced approximately every two years. On belt drive fans, the pillow block bearings and belt should be checked every three months. After the initial burn of two to six hours shut the boiler down and retighten the pillow block bearing set screws. To tighten the fan belt, loosen the four bolts that hold the motor to the bracket. Slide the motor down and re-tighten, being careful that the motor is properly aligned with the fan shaft. Some models have a hinged motor mount with adjusting screws. To check for proper alignment of the pulleys, use a straight edge lying across both pulleys.

After reattaching the fan motor assembly to the boiler, turn the fan over by hand to ensure that it does not bind. If a tight spot is evident, loosen the locking pillow block collars on the shaft and move the shaft in until the fan touches the boiler and mark the shaft. Then pull the shaft out until the fan touches the abrasion shield and mark the shaft. Finally, position the shaft midway between the two marks and re-tighten the collars. Be certain to replace the belt guard if it was removed for servicing.



Belt-drive fan assembly removed from boiler and showing white gasket

FAN ASSEMBLY REMOVAL/REPAIR

This guide may be used for removal of the fan assembly and repair/removal of the fan impeller. This procedure is required when servicing the fan assembly or heat exchanger area. We recommend you contact Alternate Heating Systems for this repair procedure.



WARNING:

Disconnect power to boiler before beginning this procedure.

1. Remove electric wires and conduit at fan motor or junction box....

Note: Mark connections before disconnecting wires.

2. Remove the four nuts, which hold the fan assembly to the boiler. These are the outer circle of nuts on the fan plate.



3. Remove the fan assembly from the boiler and place on workbench.
4. Remove the two ¼ - 20 square head set screws in the fan hub.

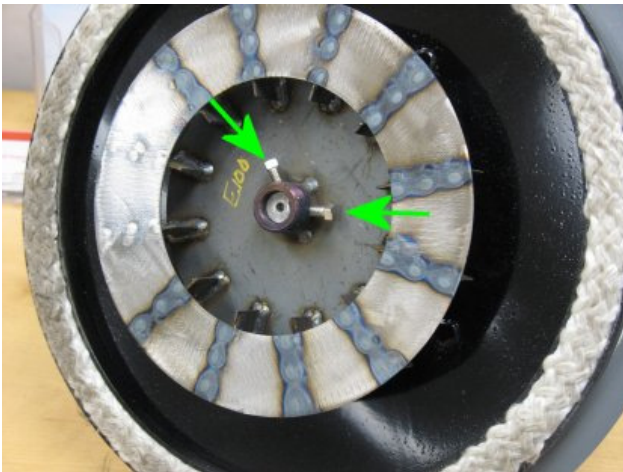

5. Thread a hex nut, size 1-14 (NF), to the hub of the fan.



6. Using a manual jaw puller attached to the 1-inch nut, carefully pull the fan from the motor shaft.

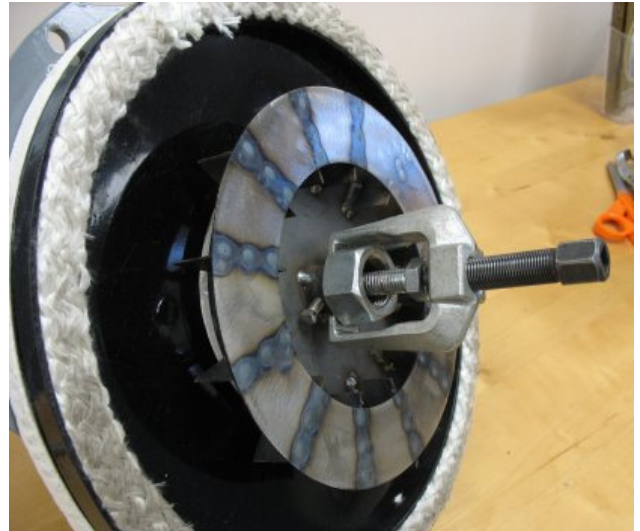

7. Clean shaft and apply a thin coat of anti seize lubricant to the shaft.
8. Place a new fan on shaft aligning one set screw hole with the keyed part of shaft. Notes: Fan hub should extend ¼ inch beyond the shaft.
9. Apply anti seize to the two set screws and install both securing the fan to the shaft.
10. Attach fan assembly to boiler and reconnect the wires.

DIRECT DRIVE MOTOR BEARING REPLACEMENT

This guide may be used for replacement of direct drive induction fan motor bearings. We recommend you contact your Alternate Heating Systems for this repair procedure.



WARNING:

Disconnect power to boiler before beginning this procedure.

1. Follow steps 1 – 6 of Fan Assembly Removal/Repair procedure. These will guide the removal of the fan assembly.
2. On bottom of fan assembly, mark all components to assure it can be reassembled in the same orientation.

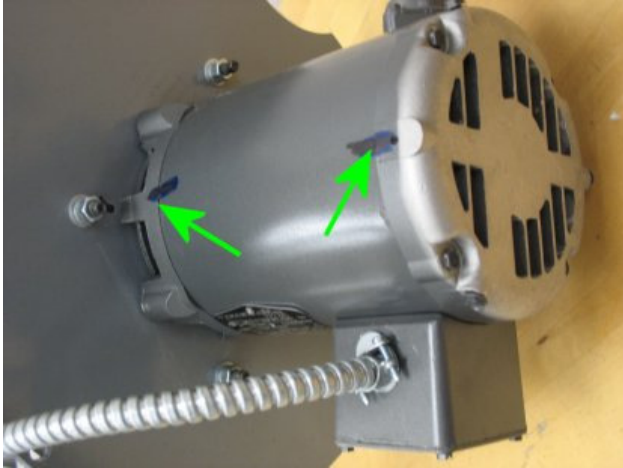

3. After fan is removed, remove abrasion shield by removing the nuts, which hold it to the fan plate. Note: these are the inner circle of nuts on the fan plate.
4. Using broad putty knife or pry bar, carefully remove the heat shield (ceramic insulation board) from the fan plate.

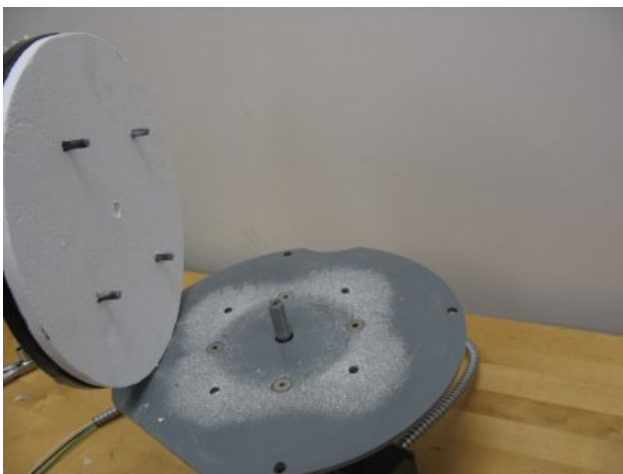

5. Using a hex key (allen wrench) remove the 4 countersunk screws, which hold the fan plate to the motor.



6. Remove back cover (fan cover) from motor. The illustration in step 2 shows the motor with this cover already removed. It is secured with 3 screws on the outside of the motor.



7. From back of motor, remove the four long screws holding motor and plates together.



8. Set motor on back, shaft end up, on a workbench.
9. Using a small hammer, gently tap up on the end plate at shaft end.



10. The plate along with the armature will come loose which should be gently lifted out.



11. Check to be sure the belleville (cupped spring) washer stayed in the end cap remaining with the motor housing.
12. Remove the two screws holding the bearing to the front end cap and gently tap end cap off.



13. Using a manual jaw puller, remove bearing from shaft.

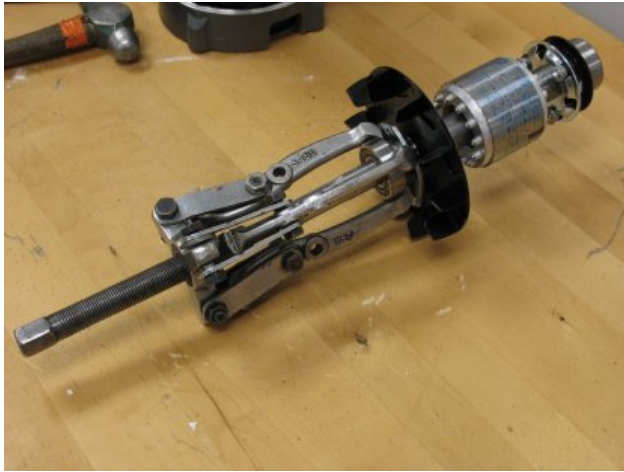

14. Install new bearing. Do not apply force on outer bearing race.

ADDITIONAL INFORMATION

For additional information on using your boiler safely, obtain a copy of the National Fire Prevention Association publication "Using Coal and Wood Stoves Safely", NFPA No. HS-8-1974. The address of the NFPA is 470 Atlantic Avenue, Boston, Massachusetts 02210.

OPERATION AND MAINTENANCE SCHEDULE FOR MODELS S130, S260, S500 AND S1000

INTERVAL	ITEM	PROCEDURE
As Needed	Ash removal	Remove ash and observe condition of ash. Adjust grate timer if necessary.
Weekly	Fire bed (when burning poor quality coal)	Check for clinkers and remove if necessary. Note: poor coal quality produces clinkers.
Every 3 months	Roller chains	Lubricate with chain oil and take up slack.
Every 3 months	Drive belt	Check belt condition. Replace or adjust tension.
Every 3 months	Fan shaft bearings(belt drive models only)	Grease with high temperature grease.
Every 6 months	Abrasion shield	Check for leakage around gasket. Adjust or replace if necessary.
Every 6 months	Flue pipe	Check for leakage around seams and re-seal if necessary
End of season	Cam bearing on grate	Check to make sure bearings are free to rotate.
End of season	Fire box	Clean and inspect fire box
End of season	Swirl chamber	Clean and Remove any buildup with boiler a boiler brush. Inspect fan condition look for cracks and wear.
End of season	Ceramic heat shield	Check for wear around fan shaft hole – replace if gap is greater than 1/16”
End of season	Flue pipe	Remove flue tube assembly and clean Inspect cyclone funnel

APPENDIX E: TROUBLESHOOTING GUIDE

PROBLEM	POSSIBLE CAUSE	SOLUTION
1.Boiler overheating	<ul style="list-style-type: none"> a) Sight hole cover flap not releasing when fan stops b) Excessive chimney draft c) Aquastat set too high 	<ul style="list-style-type: none"> a) Check spring for proper tension b) Install barometric damper in flue c) Reduce aquastat setting
2. Pressure relief valve vents	<ul style="list-style-type: none"> a) Expansion tank too small or “water logged” b) High limit aquastat not functioning 	<ul style="list-style-type: none"> a) Add expansion tank capacity necessary for total volume of water in system b) Check wiring and replace aquastat if malfunctioning
3. Fire box not full of coal	<ul style="list-style-type: none"> a) Obstruction in coal hopper 	<ul style="list-style-type: none"> a) Check hopper
4. Coal burns up inlet tube	<ul style="list-style-type: none"> a) Grate not removing spent ash b) Fused coal (clinkers) in coal pot 	<ul style="list-style-type: none"> a) Check for problem in grate motor circuit or mechanical linkage b) Remove clinkers (fused coal ash)
5. Fire goes out	<ul style="list-style-type: none"> a) Insufficient demand to maintain fire b) Large clinkers 	<ul style="list-style-type: none"> a) Increase heat load b) See paragraph at end of troubleshooting guide
6. Excessive fly ash in chimney	<ul style="list-style-type: none"> a) Cyclone funnel plugged b) Flue pipe between boiler and chimney too long. 	<ul style="list-style-type: none"> a) Check cyclone funnel and remove restriction. b) Reduce length of pipe run
7. Excessive sulfur odor in boiler room	<ul style="list-style-type: none"> a) Coal quality low b) Chimney draft problem: <ul style="list-style-type: none"> 1)Down draft 2)Restriction in Chimney c) Cyclone funnel on Coal Gun has deteriorated 	<ul style="list-style-type: none"> a) Find better quality coal b) Inspect chimney <ul style="list-style-type: none"> 1) Check chimney design & improve 2) Check & clean chimney c) Replace cyclone funnel
8. Poor boiler performance	<ul style="list-style-type: none"> a) Inadequate air for combustion b) Obstruction to air flow c) Excessive ash in coal pot 	<ul style="list-style-type: none"> a) Supply adequate air supply b) Inspect and clean swirl chamber. Remove and clean cyclone insert. c) Adjust ash removal controls.

9. Coal gas ignitions (evidenced by an audible bang) during off cycle	a) Poor draft	a) Assure at least .04" of WC with a manometer. Increase flue height if necessary, or use an auxiliary power vent
10. Coal gas ignitions during on (active firing) cycle	a) High volatile coal or insufficient secondary air b) Poor draft	a) Adjust secondary air port on sight tube cover b) Assure at least .04" of WC with a manometer. Increase flue height if necessary, or use an auxiliary power vent
11. Coal gas ignition at very end of firing cycle	a) Excess chimney draft, resulting in delayed release of sight tube cover	a) Install barometric damper or adjust existing barometric damper to .04" water column
12. Coal gas ignition at beginning of firing cycle	a) Too much coal added to emptied hopper b) Too small a fire relative to coal volume above fire	a) Do not allow hopper to run empty b) Adjust grate controls or increase heat load

Checking/Removing Clinkers

Clinkers are clumps of burned coal that have been fused together. Some coals are more prone to create clinkers than others. They can be eliminated by changing the settings of the ash controller on the boiler. Clinkers that are approximately baseball size or smaller will be carried to the ash pan. Larger sized clinkers could cause the fire to go out if the boiler is unable to remove them.

To remove large clinkers, remove the draft flap cover and move draft flap to the side. Insert a metal rod in the sight tube and run it up and down (to the grate) through different areas of the coal pile checking for clinkers. Use the rod to break up any clinkers you find. If necessary, you can use a hammer to strike the end of the rod to break them up. You will not damage the grate if you hit it as it is made of 1/2" steel. Once the clinkers are broken up they will fall on to the grate and carried to the ash pan.

APPENDIX F: TABLE OF FIGURES

Figure 1: Proper chimney connection.....	5
Figure 2: Stove pipe passing through wall	6
Figure 3: Pressure regulating valve and backflow prevention valve configuration	11
Figure 4: Plumbing – Coil in Series	12
Figure 5: Plumbing – Coil in Parallel.....	13
Figure 6: Tempering valve	13
Figure 7: Plumbing – Coil with circulator.....	13

APPENDIX G: PROGRAMMING GRATE CONTROL

Note: Your grate control comes preprogrammed from the factory. If you merely wish to change the temperature (set value, *SV*) at which the grate operates, this is accomplished by going directly to step 5 on the next page (Setting Grate Operation Control):



DWYER 16C-2 PROGRAMMING

INITIAL PROGRAMMING

1. Selecting Input Type

- A. Hold button for three seconds, until you see:
- B. Scroll with or until you see input type:
- C. Press

2. Setting Temperature Unit

- A. Hold button for three seconds, until you see:
- B. Press repeatedly until you see
- C. Scroll with or until Fahrenheit is selected
- D. Press twice

3. Setting Control Method

- A. Hold button for three seconds, until you see:
- B. Press repeatedly until you see
- C. Use or until the readout shows
- D. Press twice.

4. Setting Temperature offset for Grate Control (Heating Hysteresis)

- A. Press , the top LED readout will display
- B. Use the or to set the bottom readout to a value of 5
- C. Press twice

5. Set Grate Operation Temperature

Use and to select temperature. When the desired temperature setting is shown in the bottom readout, press . The grate operating temperature is set at the factory to 140° F. When the ash temperature drops to 5° (or whatever offset value is entered in step 4.) below the set value the grate system will remove ash. A.H.S. strongly recommends not setting the S.V. temp below 120° F and not above 150°F.

LOCKING CONTROL

Press twice, LOC will be displayed, press to set bottom readout to 1, Press
UNLOCKING CONTROLS Press and at the same time (until display blinks). Then set the operation temperature, as in step 5. (Set Grate Operation Temperature) above.

APPENDIX H: DUMP ZONE WIRING APPLICATIONS

Example 2: Multiple Zone Valves
(120 volt wire connected to Red)

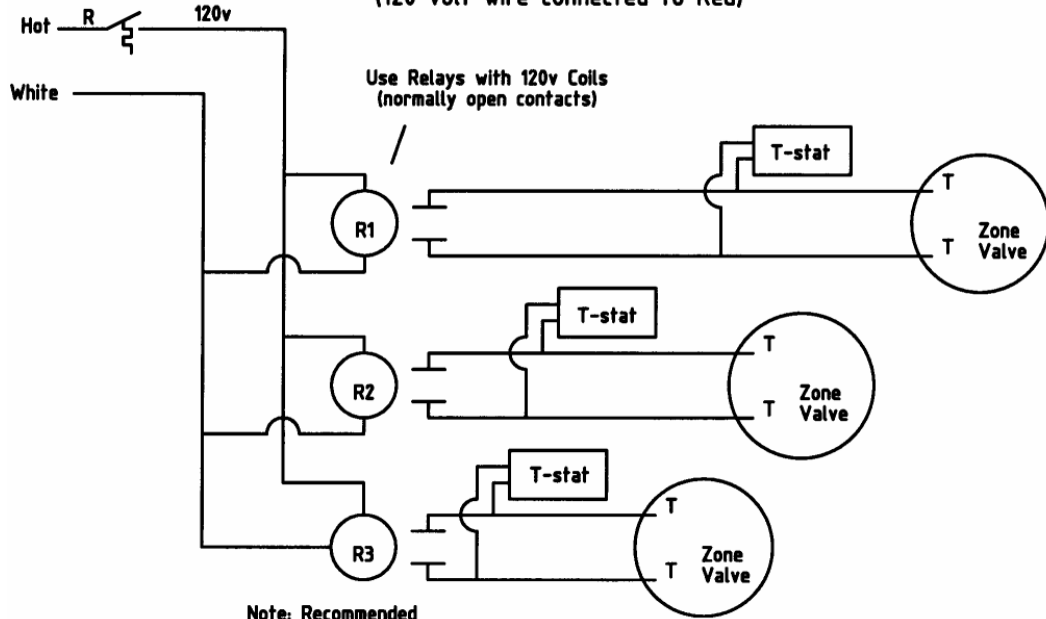

Use Relays with 120v Coils
(normally open contacts)

Note: Recommended relay is RIBU1C by Functional Devices

Example #3 Single Zone Circulator

(120 volt wire connected to R)

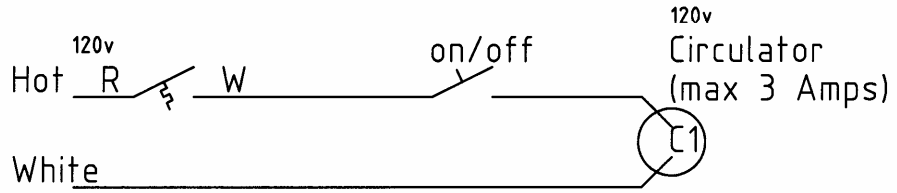

Example #4

Use of Dump Zone without use of
120v wire. The control is used as a
dry contact switch (low voltage application).
Use 300v or higher THHN or THWN rated
wire.

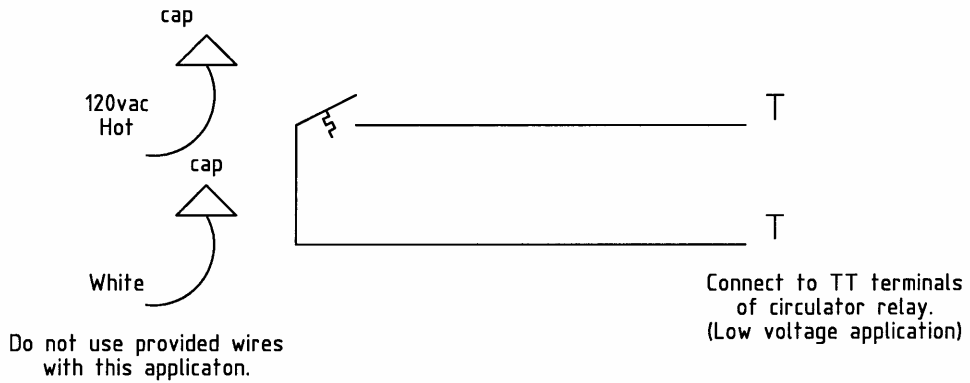

Dump Zone Example 5

(Domestic Water used as Dump Zone)

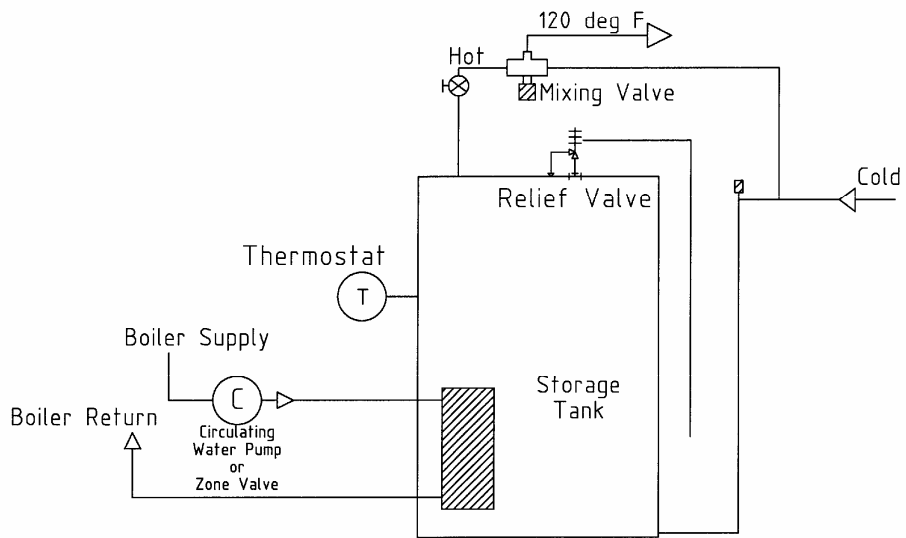

APPENDIX I: BOILER PIPING EXAMPLES

Coal Gun used in a Primary/Secondary System

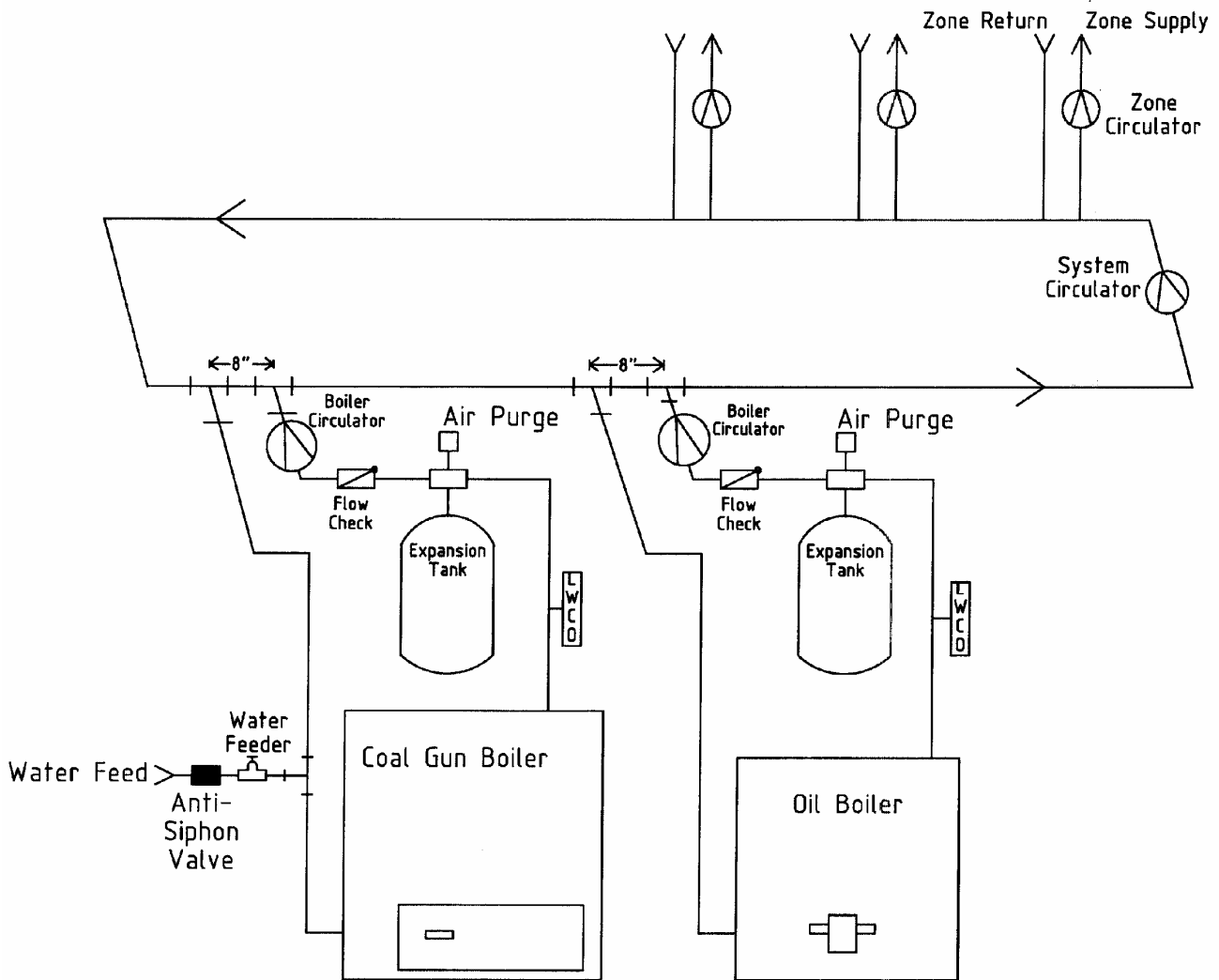

Note:

1. A call for heat from any zone activates Boiler Circulators, System Circulator and Zone Circulator.
2. Each Boiler Circulator is also controlled by a low limit to prevent operation when the Boiler is cold.
3. Dump zone operation will activate one or more zones, System Circulator and Boiler Circulator.
4. Do not bypass temperature supply control system on radiant heat system. In radiant heat applications, permit activation of a call for heat but allow system controls to regulate water temperature.

Not all system components, valves and devices are shown in this drawing. Actual conditions and application requirements will vary. Please consult a heating expert or your Alternate Heating Systems dealer for additional information.

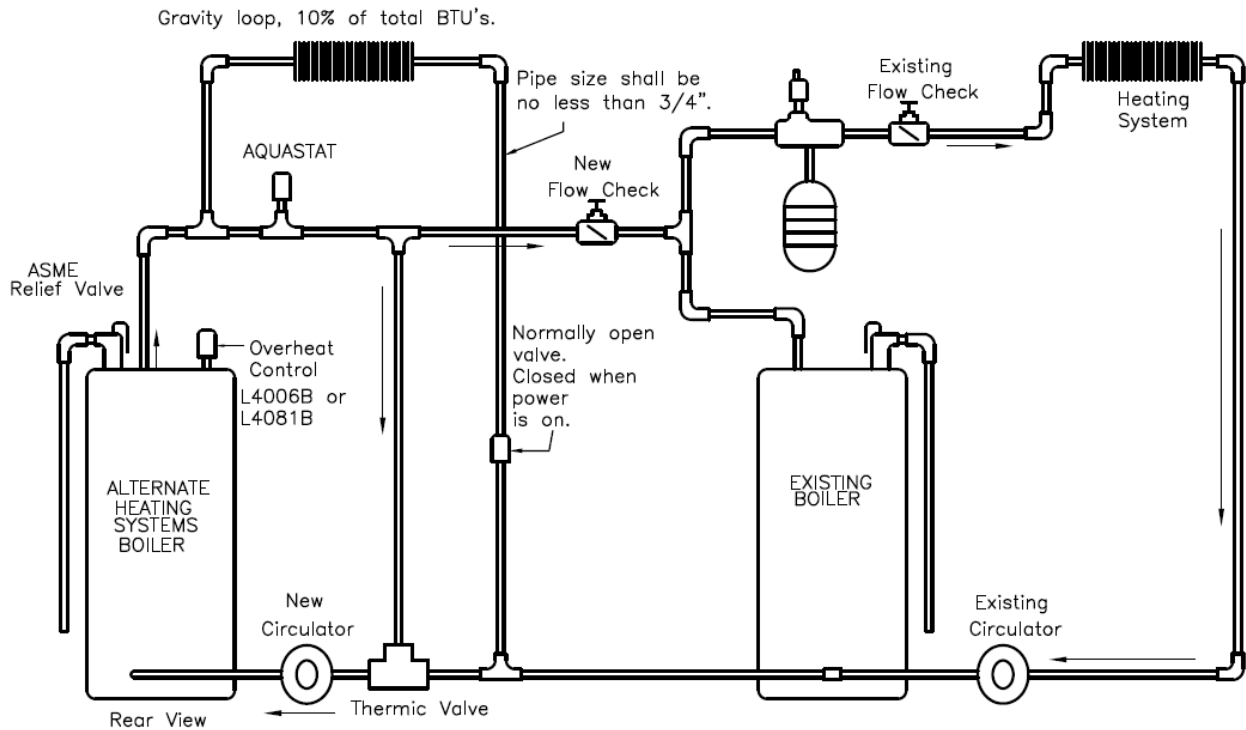

Note: The above illustrates one possible method of connecting the Coal Gun™ with an existing boiler. This connection is as follows: using a small circulator (and with the backup boiler piped into the return tapping) run another pipe from the supply tapping T, of the Coal Gun™ to the supply line, of the existing boiler on the lower side of the flow control valve. A minimum of 1" diameter pipe should be used for this connection on the model S130. The pipe size must be determined by taking into account the distance involved and flow required. The new circulator should be wired to the power for the Coal Gun. When power to the Coal Gun is on, the circulator should be running. An alternate option is to attach a strap on aquastat on the Coal Gun supply line that closes on temperature rise. This will automatically activate the pump at a given temperature. **The add-on boiler shall be installed without interfering with the normal delivery of heated water from the original boiler. The add-on boiler shall be installed without affecting the operation of the electrical and mechanical safety controls of the original boiler.**

LIMITED WARRANTY

COAL GUN™ COAL STOKER BOILERS: S130 S260 S500 S1000 S1500

The manufacturer, ALTERNATE HEATING SYSTEMS, warrants to the original owner, for the periods specified below, that the boiler to which this warranty applies is free from defects in materials and workmanship when installed, operated, and maintained in accordance with the printed instructions supplied with the unit.

2. WHAT IS COVERED AND FOR HOW LONG (all from date of original installation)

3. Boiler Vessel, Five (5) years. This does not cover any corrosion or deterioration in boiler vessel due to improper PH levels in water.
4. Doors (excluding gasketing, knobs, and ceramic insulation board), draft regulation mechanisms, insulation jacket, draft fan assembly (excluding ceramic heat shield), stack/cyclone assembly, firebox refractory sidepieces and center pieces – One (1) year.
5. All electrical and plumbing components and controls such as temperature/pressure gauge, safety relief valve, aquastat controllers, electric motor, domestic hot water coil, oil burner, fan shaft bearings, timer, draft motor, etc. purchased by Alternate Heating Systems from other manufacturers are limited to warranties offered by those manufacturers, typically One (1) year.
6. V-belt, pulleys, ceramic board door and fan heat shields, ceramic blanket firebox lining, fasteners, sight glass, smoke flap, door gasket and silicone rubber seal, door handle knobs, paint, wiring, and wiring devices –Thirty (30) days.
7. Coal Gun™ Grate – Five (5) years.

8. WHAT WE WILL DO AND NOT DO

9. Alternate Heating Systems will repair and replace, at our option, units or component parts found defective after inspection by Alternate Heating Systems or our authorized representative during the periods outlined above.
10. Alternate Heating Systems SHALL NOT BE LIABLE UNDER THIS WARRANTY IF:
 - a) the unit or any of its component parts have been subject to misuse, alteration, unauthorized repair, neglect, accident, or damage from handling.
 - b) the unit is not installed, operated and maintained in accordance with the printed instructions supplied with the unit and in accordance with local plumbing and/or building codes.
 - c) the unit is operated above its rated output which is shown on the nameplate attached to the unit and listed in Alternate Heating System's printed literature.
 - d) the unit is fired with fuels other than those recommended by Alternate Heating Systems. This includes fuels recommended by dealers and distributors selling Alternate Heating Systems products if these are not fuels recommended by Alternate Heating Systems.

11. WHAT THE CUSTOMER MUST DO

12. Contact the dealer who sold you the unit.
13. If said dealer cannot be located, contact any other Alternate Heating Systems dealers in your area.
14. If you are unable to locate a dealer, submit your warranty claim directly to Alternate Heating Systems at the address listed below.
15. When you make an inquiry or warranty request, be sure to include the following information:
 16. Unit model number
 17. Serial number
 18. Date of installation
 19. Dealer's name
 20. Type of fuel burned
21. The OWNER and not Alternate Heating Systems or its dealers will be liable for the following costs involved in repair or replacement of the defective unit or component part
 22. All necessary costs in returning the defective unit or component part to the factory or other location designated by Alternate Heating Systems.
 23. All freight and delivery costs of shipping a new or required unit or replacement component part to the owner.
 24. All labor and other costs incurred in the removal of the defective unit or part and installation of a new or required unit or part.
 25. Any material required to complete installation of new or required unit or replacement part.

26. LIMITATIONS AND STATE LAW RIGHTS

27. Alternate Heating Systems neither assumes nor authorizes any representative or other person to assume for it any other obligation or liability in connection with its products other than expressly written here.
28. Implied warranties of merchantability and fitness for a particular purpose are limited to the duration of this LIMITED WARRANTY.
29. Alternate Heating Systems shall not be liable for any incidental or consequential damages such as water, smoke or heat damage to property arising directly or indirectly from any defect in its products or their use.
30. Some states do not allow limitation on how long an implied warranty lasts and the exclusion or limitation of incidental or consequential damages, so the above limitations and exclusions may not apply to you.
31. This warranty gives you specific legal rights and you may also have other rights, which vary from state to state.
32. The remedies set forth herein shall be the exclusive remedies available to the owner.

ALTERNATE HEATING SYSTEMS, LLC.

1086 Wayne Ave.
Chambersburg, PA 17201
(717) 261-0922

IMPORTANT: READ AND KEEP IN YOUR POSSESSION!

1)Index

A		D		L	
Abrasion shield.....	37	disconnect		leaks	
air supply	2	electrical	2	chimney	4
Air Supply		draft		Line Loss.....	23
combustion	6	chimney	3, 4	low water control	10
air temperature		Draft Controls	6	low water cut-off.....	10
in forced-air systems.....	11	Sizing.....	8	low-water cut-off control..	10
anthracite	16	Drive belt	37		
Ash removal	19, 37	Drive belts.....	31	M	
ASME.....	9			Maintenance.....	31
automatic fuel delivery.....	17	E		manometer.....	4
		expansion tank	9	mobile homes	
B		EXPLOSION HAZARD3, 18		not approved for	3
boiler drain	9	F		moving the boiler	3
boiler location.....	2	Fan			
boiler piping	9	maintenance.....	32	O	
Boiler Room		Fire bed	37	Operating Information	16
Requirements	2	Fire box.....	37	Operation and	
		floor		Maintenance Schedule...	37
C		installation area.....	2		
Cam bearing	37	floor drains.....	2	P	
CAUTION 2, 4, 9, 10, 11, 16		Flue pipe	37	pea coal	16
Ceramic heat shield	37	forced hot air systems.....	10	pitman shaft.....	31
Chimney				plumbing	
Connection.....	5	G		for domestic hot water	11
inspecting.....	32	GPM Flow	23	positioning boiler	2
chimney height	4	grate switch.....	16	pressure	
CHIMNEY				measuring	4
REQUIREMENTS.....	3	H		Pressure Drop.....	23
cleanout		heat exchange coil	10	pressure relief valve	9
chimney	5	hot water			
clearances		domestic.....	11	R	
installation	3	hot water heater	11	roller chains.....	31
coil				Roller chains	37
air	10	I			
Conditioner		Installation	1, 2	S	
Boiler	10			Sealant	
creosote.....	4			Boiler	10
Cyclone funnel	38			sight hole cover	16

