



INSTALLATION AND OPERATOR'S MANUAL

WOOD GUN™ WOOD GASIFICATION BOILER

Model: E155 SS



IMPORTANT: IN ORDER TO ACHIEVE SAFE AND SATISFACTORY RESULTS FROM YOUR ALTERNATE HEATING SYSTEMS BOILER, READ SAFETY RULES AND INSTRUCTIONS CAREFULLY BEFORE INSTALLING AND OPERATING. ALL INSTALLATIONS MUST BE IN ACCORDANCE WITH STATE AND LOCAL CODES. SAVE THESE INSTRUCTIONS FOR FUTURE REFERENCE.



Your Alternate Heating Systems Boiler is capable of generating very hot temperatures. Boiler temperatures and flames in the ignition box area are capable of causing ignition or explosion of explosive or flammable products or explosion of the boiler itself if maximum safe water temperature is exceeded. Maximum safe water temperature is 200° Fahrenheit. Flammable or explosive products must never be stored in the same room or in the vicinity of a boiler, and the boiler water temperature must never be allowed to exceed 200° Fahrenheit.

ALTERNATE HEATING SYSTEMS
2393 LITTLE EGYPT RD
HARRISONVILLE, PA 17228
717-987-0099
WWW.WOODGUN.COM
EMAIL:SERVICE@WOODGUN.COM

Record Model and Serial Number Below:

Model:
Serial Number:
Date of Purchase:

**Copyright 2000 – 2015 Alternate Heating Systems.
No portion of this publication may be reproduced without the
express written consent of Alternate Heating Systems.**

Revision: 10/10/17

Table of Contents

Introduction.....	1
Explanation of Wood & Biomass Combustion.....	1
Wood Moisture Content & Wood Gasification.....	1
Mode of Operation.....	2
Reduce or Prevent Condensation.....	4
Proper Pressurization of the Wood Gun.....	4
Boiler Installation.....	5
Boiler Location.....	5
Boiler Room Requirements.....	5
Rigging and Positioning of Boiler.....	6
Clearances to Combustibles Required for Safety and Operation.....	6
Boiler Assembly.....	6
Cyclone Ash Collector.....	6
Air Valve.....	7
Draft-Inducing Fan Assembly.....	7
Installation and maintenance of Electrical Controls and Gauges.....	7
General Chimney Requirements.....	8
Specific Chimney Requirements for the Wood Gun™.....	8
Flue pipe.....	9
Proper Chimney Connection.....	9
Boiler Piping for Hydronic Systems.....	10
Piping the Boiler in Parallel with Another Boiler.....	11
Pressure Relief Valve.....	11
Pressure Reducing Fill Valve.....	11
Expansion Tank Selection.....	11
Return Water Temperature.....	12
Return water temperature.....	12
Low Water Cutoff.....	13
Recommended Boiler Control Settings in Hydronic Systems.....	13
Boiler Conditioner / Sealant.....	14
Boiler Piping and Controls for Low Pressure Steam Systems.....	14
Forced Hot Air Systems (Water to air Coil in Duct).....	14
Domestic Hot Water Coil Piping.....	15
Oil Burner Assembly.....	16
General Information.....	16
Oil/Gas Burner Combustion Chamber: Models E155.....	16
Oil Burner Electrical Connection.....	16
Oil Burner Fuel Line Connection.....	16
Oil Burner Adjustment.....	17
Gas Burner Assembly.....	17
Gas Burner Adjustment.....	18
Oil Automatic Switchover and Lockout Control.....	18
Smoke flap.....	18
Operating Information.....	21
Starting a Fire: Switch Positions.....	22
Switch Positions: Cold Boiler Start-up.....	22
Fuel Type.....	22
The Wood Gun is designed to burn split or unsplit wood.....	22
Starting a Fire: Procedure.....	22

Charging the Boiler with Wood: Manual Feed.....	23
Back-Puffing Prevention Checklist.....	24
EPA Side Tunnel Refractory Plug.....	24
Wood Fuel Characteristics and Wood Storage.....	25
Low Water temperature Option.....	25
Cool Down Cycle.....	26
Wood FUEL CHARACTERISTICS AND WOOD STORAGE.....	26
Removal and Disposal of Ashes.....	26
Conditioning of Boiler Water.....	27
pH.....	27
Dissolved Oxygen.....	27
Solids (Primarily for Steam Boilers).....	28
Alkalinity.....	28
Phosphates.....	28
Hardness.....	28
Oils.....	28
Maintenance.....	29
Weekly Cleaning Procedure.....	29
Air Valve Cleaning and Maintenance.....	29
Yearly Cleaning.....	30
Air Valve Motor Replacement.....	30
Removing Old Damper Motor.....	30
Installing the New Damper Motor.....	30
Door Adjustment.....	31
Load Door Seal Replacement.....	32
Front and Rear Inspection Door High Temperature Rope Installation.....	34
Fan Assembly.....	35
Direct Drive Fan bearing replacement procedure.....	36
Refractory Replacement.....	39
Center Brick.....	39
Side brick Refractory Replacement.....	40
Fuel Diverter Blocks: auto Feed Only.....	41
additional Information.....	41
Appendix A: Boiler Specification Diagram.....	42
Additional Specifications.....	45
Pressure Drop.....	45
Explanation of GPM Flow.....	45
Wood Gun E Series Specifications.....	45
Appendix B: Wiring Diagrams.....	46
.....	47
Appendix C: Exploded Parts Drawings.....	48
Parts Listing.....	49
Appendix D: Troubleshooting Guide.....	52
Appendix F: Boiler Piping and Ducting Examples.....	55
LIMITED WARRANTY.....	59

Introduction

The purpose of this manual is to assist you in the installation, operation and maintenance of your new boiler in order to achieve the best performance possible.

We recommend that the unit be installed by a qualified installer who has a thorough knowledge of hydronic heating boiler systems and will comply with all of the requirements of the authority having jurisdiction over the installation. Should your installation be a steam boiler, it is even more important that experienced personnel be consulted to ensure that the necessary safety controls are installed and properly wired.

Read the entire instruction manual carefully and understand it thoroughly before installing or operating this unit. Save these instructions and review them periodically as an aid to maintaining your boiler and following safe operating practices.

All Alternate Heating Systems boilers can be supplied with the ASME "H" stamp and National Board number for an additional fee when requested prior to purchase. Alternate Heating Systems boilers are built to the most rigid quality control standard. You can be assured that you will receive the highest quality product.

EXPLANATION OF WOOD & BIOMASS COMBUSTION

The burning of wood involves a series of very complex chemical reactions that are time and temperature dependent. The pieces of wood (or particles) may be thought of as containers that store combustible gases that are released when heat is applied. The various gases that emanate from heated wood have ignition temperatures ranging from 540° F to 1125° F. This helps to explain why high temperature is so important in achieving "complete" combustion in burning wood. In a conventional wood stove a significant portion of the combustible gases released from the wood goes up the chimney unburned to become deposited on the chimney walls

as creosote or escape as visible smoke. In the Wood Gun™ a greater percentage of the combustible elements released from the wood are combusted due to the high temperatures attained, usually within even a few minutes of re-ignition.

The time it takes for smoke to disappear from boiler exhaust on startup depends largely upon the temperature of the refractory. A boiler being fired from a cold start may emit some smoke for several minutes. When the boiler is reigniting after an off cycle (hot or warm start) there may be very little to no visible smoke. The length of the last firing cycle and the amount of elapsed time since the boiler last fired will affect refractory temperatures and the amount of visible smoke when the boiler re-fires. A Wood Gun™ operating under normal load will produce only a small amount of smoke on startup and burn cleanly shortly thereafter.

WOOD MOISTURE CONTENT & WOOD GASIFICATION

The moisture content of wood is a critical factor affecting wood gasification, as it determines how rapidly pyrolysis (gasification) can occur. Wood moisture content moderates the rate of gasification by limiting the rate of heat gain in the wood. Wood with higher moisture content will gasify more slowly. Wood with excessive moisture content will not gasify until a large amount of water has been driven out of the wood. This consumes energy that would otherwise be usable heat. The dilemma that faces the boiler operator using higher moisture content wood is that the boiler must be operated so that more heat goes up the stack (in order to drive water vapor out of the system) or else the operator will be faced with significant and troublesome condensation.

Wood with moisture content higher than 30% is more likely to produce condensation issues and will produce markedly less BTU's per pound of fuel.

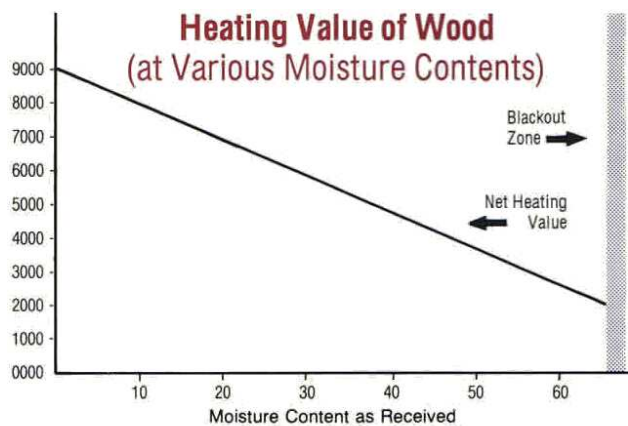

Source: Tillman, David A., Wood as an Energy Resource

Very dry wood creates a different problem. With dry wood, pyrolysis temperatures are achieved more quickly and the rate of gasification is accelerated. This may result in the consumption of available oxygen faster than it can enter the boiler. The fire could then begin to release smoke due to a phenomena known as “back puffing”; “Back puffing” results in smoke being pushed out through the intake in intermittent, and often audible, puffs. Low moisture fuel (< 15% moisture) requires special considerations for a satisfactory burn. Dry sawdust and shavings are less of a problem than kiln-dried solid blocks or logs.

An optional secondary air tube installed in the rear of the boiler will reduce the problems associated with burning very dry fuels. This tube permits preheated air to pass from the firebox directly into the rear of the center combustion chamber. In rare cases, it may be necessary to add moisture to the fuel by storing it outside or by installing a water mist system on the auger of units using an automatic feed system

With medium moisture wood, 20-30%, the combustion process is more constant, with pyrolysis and the combustion of gases and charcoal occurring close to a constant rate. This moisture content of 20-

30% is optimum for burning wood in the gasification process.

Because of the downdraft design of the Wood Gun™, the rate of air admitted to the unit is fairly constant regardless of the type and amount of fuel being burned.

Most pyrolysis occurs between 540° F (280° C) and about 900° F (500° C). The most abundant gases produced are carbon monoxide, methane, methanol, formaldehyde, and hydrogen as well as formic and acetic acids, water vapor and carbon dioxide. All of these elements must pass through the refractory combustion chamber where, in the presence of high temperatures and oxygen, they are reduced to carbon dioxide and water. By the time the temperature of the fuel reaches 900° F (500° C) pyrolysis is complete and the final solid product is charcoal, which is almost pure carbon.

MODE OF OPERATION

The Wood Gun™ operates on the well known principle of gasification which makes it possible to burn wood and wood waste products at high efficiency and free of creosote formation in the chimney. The bottom of the fuel chamber is lined with pieces of dense refractory casting, which contain the primary combustion zone. This combustion zone is linked to the fuel chamber by a series of openings. The gases produced from pyrolysis of the fuel charge are drawn through the openings into the refractory combustion chamber where a very intense flame exceeding 1800° F (1000° C) is produced. Heat generated in the combustion chamber radiates throughout the refractory mass heating the fuel charge above. As the fuel charge is subjected to heat, the moisture is driven from the wood and it begins to char, releasing a variety of combustible gases.

The gases produced during pyrolysis would not normally follow a downward path, so a draft-inducing fan is employed to create a partial vacuum that draws the flame through multiple tunnels in the refractory. These refractory tunnels make up the

primary combustion area in the Wood Gun™. This long flame path provides sufficient retention time for the gases to cause near complete combustion to occur before the hot gases come in contact with the water-backed heat exchanger surface.

The mass of refractory that encompasses the combustion chamber also serves a second important function, acting as a heat store to initiate re-ignition after a period of no demand. When the air valve closes and the draft inducing fan stops, the fire is extinguished by lack of oxygen and becomes dormant. The fire will re-ignite once the air valve opens and the draft-inducing fan is powered on, as long as the refractory still retains enough heat to cause combustion to take place. The fuel may remain dormant for periods of four hours or more depending upon the size of unit and the temperature of the refractory at shutdown. By utilizing this combination of features, fuel is burned at maximum efficiency, only as heat is required, and never as a low smoldering fire. Smoldering fires, and colder than optimum fires, produce excessive amounts of creosote and smoke.

When a demand for heat exists, the operating aquastat will open the air valve and activate the draft induction fan. At this time, abundant air is provided for combustion. When the boiler temperature reaches the level set on the aquastat, the fan stops and the air valve closes.

The fan that creates the negative pressure in the combustion chamber inversely produces positive pressure in the cyclone ash separator located at the discharge point of the heat exchanger. Most of the ash that remains after the wood is consumed is collected here.

The Wood Gun™ is very responsive to heat demand, especially when compared to conventional wood boilers. Because of this responsiveness, providing domestic hot water in the summer may be practical. Alternate Heating Systems cannot promise that summer time use of a Wood Gun will be practical for you.

If summertime hot water requirements are low it may be necessary to add a draft cycle timer to the electrical control circuit to make the unit run for 8 to 10 minutes every two to four hours. This will prevent the fire from going out and more importantly will maintain sufficient temperature in the refractory to ensure complete combustion on start-up. This feature will provide heat until the timer reaches the end of the programmed cycle, or until the boiler temperature high limit is reached.

Note: Some of the byproducts produced by incomplete combustion of wood are formaldehyde, formic acid and acetic acid, which are mildly corrosive. A Wood Gun™ operating under light demand may never generate refractory temperatures sufficient to reduce these organic compounds to water and carbon dioxide. Any air leak around the inspection doors or air valve may contribute to the formation of corrosive products. Therefore it is important to inspect your Wood Gun™ regularly to ensure that it is being operated in a manner that does not contribute to excessive corrosion of the steel. We recommend that boilers operating with lower duty cycles be manufactured with the stainless steel option. It does not override the high limit.

It is essential that all combustion air be prevented from entering the Wood Gun™ at shutdown. Where a strong chimney draft is present during the off cycle, a unit with leaking door seals may allow a small amount of air to be pulled through the unit, supporting a low-grade fire. This produces two major undesirable results.

First, incomplete combustion yields creosote and other organic compounds, which are mildly acidic. These condense on the water walls of the load chamber and heat exchanger. If this situation is allowed to continue for any length of time, the heat exchanger will become coated to the extent that airflow and heat transfer are seriously impaired.

The second undesirable result is moisture condensation. This occurs because the low-grade fire produces insufficient heat to carry the water out the stack as water vapor. Water will likely be evident in the ash pan and, in severe cases, may even collect in the heat exchanger. This water comes not only from

water moisture in the wood, but is formed as a byproduct of combustion. Excellent combustion will maximize the amount of the main byproducts of combustion, carbon dioxide and water. More water will be produced by good combustion than that originally contained in well seasoned wood. Severe condensation can result in so much liquid water that it is misinterpreted as a boiler leak. When water is found in the cyclone and/or heat exchanger, attack the issue as one related to condensation.

Note: Condensation in the heat exchanger can be caused by wood that is too wet for the application and/or by low return water temperatures. Recommended return water temperature is operating temperature minus 20° F

Reduce or Prevent Condensation

Condensation has several causes, but can always be attacked systematically and greatly reduced or eliminated. Even in early fall and late spring, condensation can be kept under control. Keep in mind that because the Wood Gun swirl tube heat exchanger extracts so much heat from the exhaust, the gases leaving the system are often not far above temperatures that can lead to condensation. Anything that compromises performance or cools stack gases further than normal can trigger condensation. Review this list and make changes that match your circumstances. Be sure to review the installation section of this manual that covers return water temperature.

- ✓ Increase return water temperatures (mixing valve, raise operating temperature)
- ✓ Check for and correct any issues related to leaking door seals or Air Valve leaks
- ✓ Insulate stove pipe and/or chimney to preserve heat
- ✓ Insulate cyclone
- ✓ Increase load

- ✓ Increase run cycle length
- ✓ Use drier fuel
- ✓ Clean boiler, or take other measures to improve air flow
- ✓ If you are observing back-puffing, take care of this issue promptly, as performance is compromised in a back-puffing boiler, possibly contributing to condensation
- ✓ Keep refractory relatively clear of charcoal and ash
- ✓ Watch loading technique and other firebox management aspects, making sure that the fire burns properly upside down

Proper Pressurization of the Wood Gun

The Wood Gun™ is designed as a pressurized boiler system. Before leaving the factory, it is pressure tested for safety. Typical hydronic heating applications operate at pressures of about 12-15 psi. A pressurized system causes oxygen to be driven from the water reducing corrosion and oxidation. Rust and mineral buildup is avoided in a pressurized system because extra water is not continuously added to make up for evaporation losses. Keep the boiler and piping properly pressurized for long life. Be sure to review information in the installation section of this manual regarding expansion tank selection.



Boiler Installation

BOILER LOCATION

Wood & Coal Burning Boilers are designed to radiate heat freely, but this heat can be dangerous if the boiler is improperly installed. The Wood Gun™ is designed and certified only for indoor installations and therefore must be protected from the elements by being located in a totally enclosed shelter. The Wood Gun™ must not be installed anywhere that gasoline, or other flammable vapors are present. Unless special preparations are made to partition off an area for the boiler and to prevent flammable vapors from entering the boiler area, a garage is not an approved location for a Wood Gun™ installation. Check local building codes for restrictions on installation.

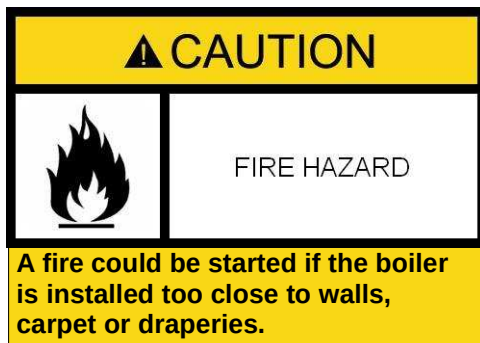

The boiler must stand on a noncombustible material such as brick, stone tile or concrete. NEVER place a boiler directly on a wood floor. The noncombustible material upon which the boiler stands should extend at least 12 inches beyond the base of the boiler in the rear and on the sides and at least 36 inches in front. The boiler must be installed in an area dedicated to the boiler and its related equipment. This area must be partitioned or separated from any living area of a residence. The room must have a constant fresh air supply to assure proper combustion of the fuel as well as ventilation of any by-products of combustion.

Boiler Room Requirements

1. The room should be well-lit and should have a source of emergency light.

2. A convenient water supply should be available for boiler flushing and to clean the boiler room floor.
3. Unobstructed floor drains.
4. A boiler must not be installed where there is the possibility of the accumulation of explosive vapors.
1. Must have adequate air supply, which must be kept clear at all times. Since the combustion process requires a supply of air at all times, it is essential that provisions are made to supply adequate air to the boiler room. This air supply is necessary to insure complete combustion and venting of any gases or smoke that would be emitted from this solid fuel-burning boiler in case boiler malfunctions. If fans are used in the boiler room or in the fuel storage room it is important they are installed in such a way that there is not a negative pressure in the room where the boiler is located.



2. Provide an electrical disconnect at point of entrance to boiler room.
3. Walls and ceiling must be of fire rated construction. Consult local or state codes for requirements.
4. It is recommended to have at least one week worth of fuel inside and kept out of the weather. Do not store fuel within the appliance installation clearances or within the space required for fueling, ash removal, and other routine maintenance operations.

RIGGING AND POSITIONING OF BOILER

Do not attempt to move or off-load the boiler without the aid of a crane or dolly. Most Alternate Heating Systems boilers have a lifting lug in the center of the top while on some units two lifting lugs in the front and rear are provided.

Once on the floor level where it will be installed the unit may be rolled on pipe or may be moved by means of a pallet jack. Use caution whenever moving a boiler. Be sure to use proper equipment and have sufficient manpower available to prevent injury or damage that can be caused by improper handling heavy equipment. The boiler must be placed on a concrete slab or other rigid pad of non-combustible material with sufficient strength to adequately support the boiler including its contents of water. The boiler should be positioned as closely as possible to the chimney. The smoke pipe must pitch continually upward toward the chimney and be as straight as possible. Level the boiler after it has been positioned.

Before proceeding with installation, inquire with local building officials to confirm compliance with that building, plumbing and electrical codes. Alternate Heating Systems recommends that a qualified technician experienced in boiler installations perform the installation of the Wood Gun™. Wiring on the boiler must be properly grounded.



CLEARANCES TO COMBUSTIBLES REQUIRED FOR SAFETY AND OPERATION

The required minimum clearances to combustibles for all models are:

Front	48 Inches
Rear	36 Inches
Left	12 Inches
Right	18 Inches
Top	24 Inches

Most municipalities require a specified clearance between the flue pipe and combustibles (normally 18 in). The customer/installer must follow all local and state building codes for clearances. The above dimensions are to be regarded as minimums. Extra clearance is recommended to allow for easy movement around the boiler for cleaning and/or maintenance. Refer to Appendix A for exterior dimensions of the various models.

It is necessary to adhere to the clearances and restrictions that are described in this manual. Extensive research and testing has been conducted to assure that these units are safe when operated according to the instructions included in this manual.

BOILER ASSEMBLY

Cyclone Ash Collector

Once the Wood Gun™ has been positioned, the cyclone ash collector should be attached to the flange on the left side of the boiler (see Appendix C: Exploded Parts Drawings).

Apply a strip of 1/8 in x 1/2 in self-stick sponge rubber (included with boiler) to the boiler flange inside of the mounting holes before attaching the cyclone to the boiler flange using three 5/16 in x 3/4 in bolts and washers. To apply, carefully remove the paper backing from the rubber strip to expose the adhesive. Overlap the strip approximately 1 inch and cut off the excess material with a knife or scissors. The adhesive will hold the gasket in place until the cyclone assembly is positioned.

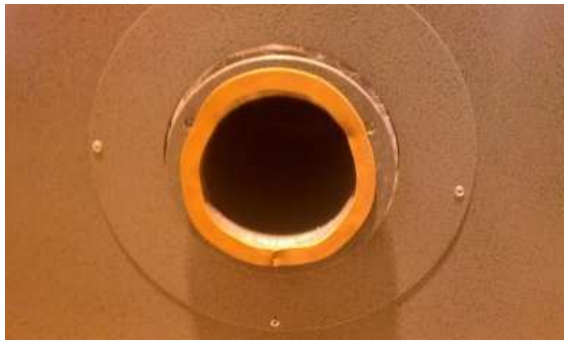

Cyclone Attachment

Air Valve

If the air valve was not installed at the factory, begin assembly by placing the stainless steel tube into the boiler opening (with the latch side up) and tighten the two setscrews.

Cement the joint with high temperature silicone sealant (included or available at a local hardware store) to prevent air leakage. A 5 in diameter, galvanized elbow is provided with a new Wood Gun™. This must be attached to the air valve inlet tube facing down. In addition, a 5 x 24 in galvanized tube is to be attached to the elbow such that combustion air is being pulled from the floor (see Appendix F: Boiler Piping Examples).

The wires from the damper motor must be inserted into the electrical box on the rear or side of

the boiler and connected as documented in the wiring diagram for the model being installed. Wiring diagrams are found in Appendix B.

Draft-Inducing Fan Assembly

The draft-inducing fan assembly may be shipped in a separate box. See Fan Assembly in the Maintenance section for assembly guidance. The fiberglass rope gasket must fit neatly in the groove without overlap or wrinkles. When tightening down the fan assembly nuts, alternate between studs and apply equal pressure until the gasket seals firmly against the end of the swirl chamber.

IMPORTANT: Do not tighten the 5/16 nuts excessively as this may damage the gasket or the ceramic board heat shield.

The wires leading from the fan motor must be inserted into the electrical box on the rear of the unit and connected as according to the wiring diagram for the model being installed (see Appendix B: Wiring Diagrams).

INSTALLATION AND MAINTENANCE OF ELECTRICAL CONTROLS AND GAUGES

Insert the temperature/pressure gauge into the right side marked tapping (JJ) on model E100 and tapping (Z) on all other models. Refer to Appendix A for details on tapping sizes and locations. The high limit aquastat occupies the left (JJ) tapping on the E100 and the (AA) tapping on all other Wood Gun™ models. On all units not equipped with an oil burner, a L4006A single aquastat is used and occupies the same position. The boiler operating limit aquastat (L6006A) is located in tapping (GG) on the rear of the boiler. On units with an oil or gas burner a L6006A aquastat for switching from wood to oil is located in tapping (zz). For detailed wiring and control diagrams, consult Appendix B: Wiring Diagrams. When installing the L.W.C.O. refer to directions on page 12.

In some cases it may be necessary to test the controls and gauges. First turn the power off. To test

an aqua stat. Turn the dial 20° past the boiler water temperature. Use an ohmmeter to test the terminals for continuity. If the contacts are closed before you turn the dial it should open afterward. If it is opened before you turn the dial it should be closed afterward. It can be common that the contacts engage or disengage +/-5° from the reading of the temperature gauge due to slow water circulation in the boiler vessel. If the temperature difference is more than +/-5° than the aqua stat should be replaced. If there is a discrepancy in the temperatures, be sure that the temperature gauge is accurate. This can be done by testing the boiler water temperature with a second thermometer or temperature gauge.

INSTALLATION OF SMOKE HOOD OPTION

AHS recommends the Smoke Hood (exhaust) for most installations inside the home. The Smoke Hood functions in much the same manner as the range hood over a kitchen stove. It vents smoke escaping from an open load door directly to the outside. The following image displays the smoke hood, mounted over the load door with the vent running upward. This vent runs horizontally in most installations. It must be separate from the chimney vent, and may go through a side wall or ceiling. Use 5 or 6 inch stove pipe and a vent flap to prevent outside air from entering when the smoke hood is turned off. Use of 6 inch stove pipe will require use of an adapter, but venting performance will be better with larger stove pipe.



Smoke Hood Installed

The smoke hood is turned on manually as needed, typically just before opening the load door to add fuel. Smoke is most commonly seen when the load door is opened with considerable fuel still left burning in the firebox. Smoke escape is also common when refractory is at good operating temperature and the firebox is being filled completely.

GENERAL CHIMNEY REQUIREMENTS

If the chimney must go through a combustible wall, be sure to use a metal thimble specially designed for this purpose. The proper way to install a thimble is to cut an oversize hole in the sheetrock about 6 or 7 inches larger than the thimble. However, be sure to follow the manufacturer's directions that come with the thimble. A metal ring shield is used to cover the hole. This way air can circulate and cool the area around the passageway.

Specific Chimney Requirements for the Wood Gun™

The Wood Gun™ creates its own draft; therefore having sufficient height in the chimney is not an issue. Excessive chimney height can allow for more cooling of exhaust gases and lead to condensation issues. Other aspects of chimney construction that lead to condensation include use of a masonry chimney that lacks an insulated liner. Having such a chimney on the outside of the house compounds this problem as well. Because of the high efficiency of the Wood Gun, and resultant low stack temperatures, it

is important to try to preserve exhaust heat. Always check with your local building inspector and insurance agent to assure compliance.

Stovepipe should be sized as follows:

- ✓ E155 not less than 6 IN diameter.

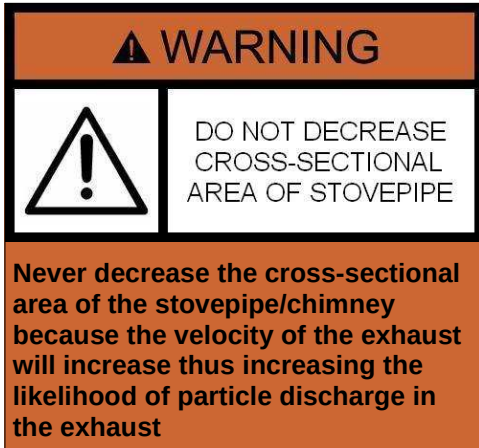

Using larger diameter stovepipe is generally not a problem. It is a good practice to run as long a vertical pipe as you can, coming off of the cyclone. You will want to avoid having an elbow or “T” immediately above the cyclone. Provision must be made for disassembly and cleaning. Excessive weight of pipe placed on the cyclone must be avoided. Utilize ceiling, roof or other supports to avoid adding too much weight to the top of the cyclone.

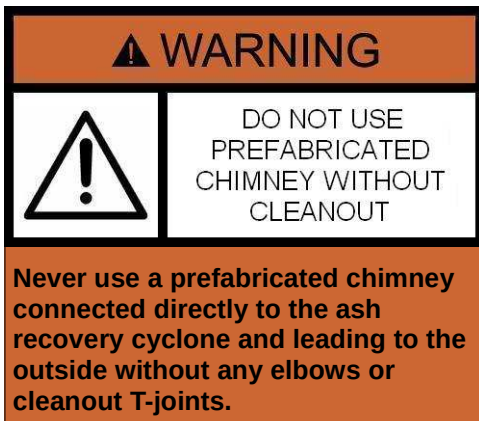

Having adequate combustion air is critical to boiler performance. This means that there must be either enough air infiltration to supply the boiler with combustion air, or other means must be put in place to provide this makeup air. There is usually sufficient leakage in older homes, typically around doors and windows. In well-insulated homes it may

be necessary to provide additional outside air into the home. It is possible to duct outside air directly to the boiler. In such situations, it may be important to provide for some heating of this air.

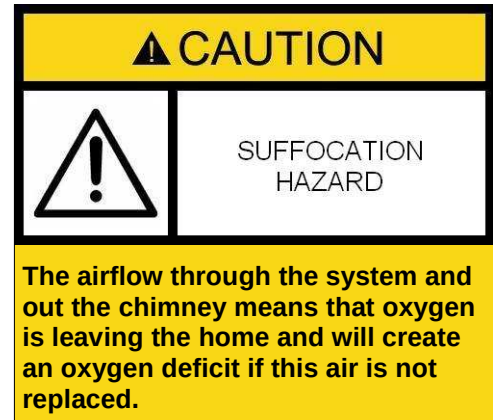

FLUE PIPE

Use only 24 gauge pipe or heavier for flue connections. We recommend stainless steel. Heavy gauge black pipe will not last very long, typically only one or two years. Galvanized pipe is not recommended. When using single wall flue pipe in open areas, assure the pipe passes no closer than 18 inches from combustible walls or ceiling. If the flue pipe must be closer than 18 inches from the nearest wall or ceiling, or if it must go through walls, closets, or boxed-in areas, then U.L. listed insulated flue pipe must be used. Flue pipe that runs along the outside walls of a building must also be U.L. listed insulated pipe, even if it runs along a non-combustible outside wall. This requirement is in place in order to prevent cooling of the flue pipe, which in turn cools the rising smoke and causes condensation and creosote to form quickly.



Do not connect more than one heating appliance to a single chimney. Be sure to check all local codes and your insurance provider's requirements for any additional restrictions and/or guidelines regarding your flue pipe.

PROPER CHIMNEY CONNECTION

The boiler must be connected to a class A chimney. The recommended method for connecting the boiler to the chimney is to place a T-joint at the top of the vertical section leading from the cyclone. Each joint should be secured with three sheet metal

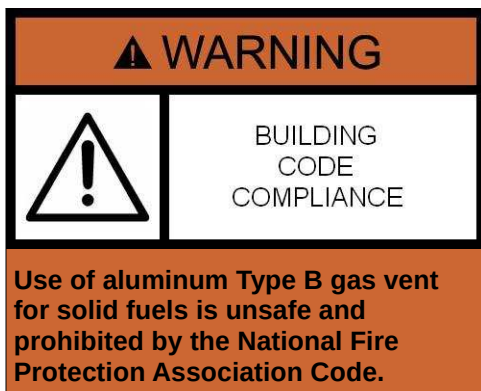

screws and sealed with high temperature furnace cement or "Troweleze" refractory cement or High Temperature Silicone. The opening on the T-joint should be fitted with a removable cap to enable cleaning and inspection. If the horizontal run to the chimney is inclined, it will encourage any fly ash which drops in the pipe to fall back into the ash separator. In many cases it is acceptable to set the stack directly on the cyclone, as long as provision is made for removal, and the length of pipe supported only by the cyclone is eight feet or less. If a taller run is required additional support is needed. This can be provided by ceiling and/or roof supports.

If a second change of direction is required before entering the chimney a cleanout "T" should be placed at this point also as indicated in Figure 1. Any horizontal pipe should be pitched upward toward the chimney at least $\frac{1}{4}$ in for each foot of horizontal run. Be sure there are at least 18 in clearance between horizontal piping and combustible ceiling. Be sure that the chimney connection pipe extends at least 2

in into the chimney, but does not extend so far into the chimney that it blocks airflow.

In installations where the chimney draft is too strong, the problem may be eliminated by allowing air to pass up the chimney from an auxiliary valve located at floor level and connected to a "T": in the flue pipe or chimney.

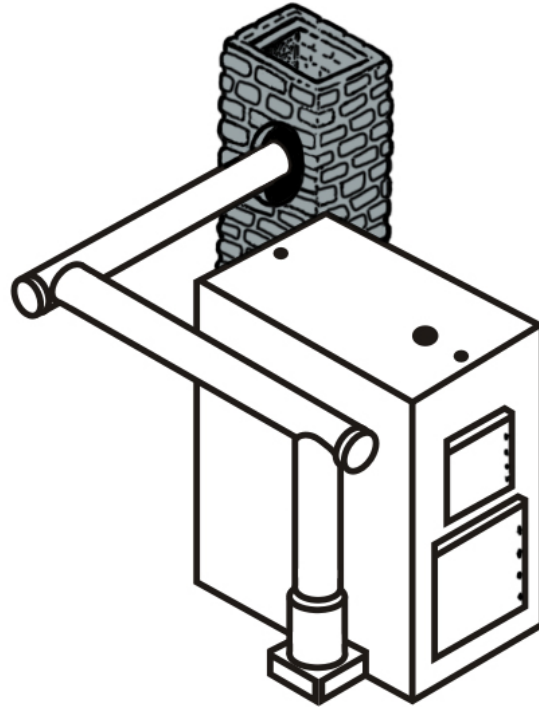

Proper chimney connection

Particular attention should be paid to the point where a flue passes through a wall or ceiling. The pass-thru should always be made with insulated pipe and the proper accessories or use of a thimble, which provides a diameter of not less than three times the diameter of the stove pipe.

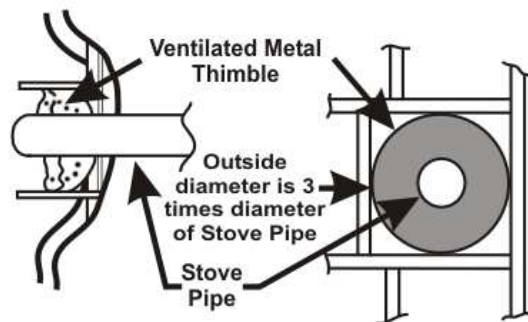

Stove pipe passing through wall



It is important to make provision for adequate supply of combustion air, either natural infiltration through or around a door or window, or by ducting outside. If the air intake valve is not ducted to the outside, then the galvanized stove pipe elbow provided with the boiler must be attached to the collar on the air valve facing downward with a 2' section attached to the elbow with three sheet metal screws. If combustion air is ducted from the outside, then follow the same procedure as described for passing a smoke pipe through a combustible wall. Should the air valve malfunction and not close completely, there is a possibility that this conduit could act as an exhaust stack and heat up. Consult Appendix F for a picture diagram.

When the intake air is ducted from the outside, inspect the opening regularly to be sure that it does not become obstructed by debris. Units that have outside combustion air ducts must have this duct routed close to the floor in the boiler room.

BOILER PIPING FOR HYDRONIC SYSTEMS

Due to the design requirements of the various Wood Gun™ models, the fittings and burner attachments are not always in the same location on each boiler model. See Appendix A for the location of these attachments. This diagram provides exact locations for all fittings. The flush-out fittings in the bottom of the unit are a requirement of the ASME boiler code and must be closed before filling the unit with water.

Note: Be sure to close all fittings in the unit before filling the unit with water.

An elbow and boiler drain should be inserted in the flush-out tapping U or Y on the bottom of the

boiler near the front. Alternately, a "T" and short nipple could be attached to the return tapping for the location of the boiler drain.

Piping the Boiler in Parallel with Another Boiler

The Wood Gun™ may be connected to a heating system supplied by one or more boilers that are already in place. To connect the boiler to the existing boiler run the supply pipe with a flow check from the Wood gun and Tee into the supply pipe of the existing boiler. This pipe will carry hot water to the existing boiler when there is no heat demand and will in turn keep the existing boiler from turning on. The return pipe with a circulator pushing toward the Wood gun will Tee into the return line of the existing boiler. It is required that the piping be such that excessive pressure will not be developed in any portion of the boiler or system. The circulator will constantly run when the Wood Gun boiler is on. Wire the circulator to the Wood Gun boiler in such a way that when the boiler switch is on the circulator will also run. The power to the Wood gun should then be controlled by an aqua stat located in the supply piping. This aqua stat should be set 10°F above operating temperature of the existing boiler. That will shut the Wood gun down if it runs out of fuel. The aqua stat will need to have a bypass switch that will allow the wood boiler to have power and enable it to be started so that it can be warmed to its operating temperature.

There are many possible configurations that allow for an existing boiler to function as a backup to the Wood Gun™. For sample illustrations of multiple boiler configurations, see Appendix F.

Pressure Relief Valve

A pressure relief valve should be inserted into tapping DD on the E155.

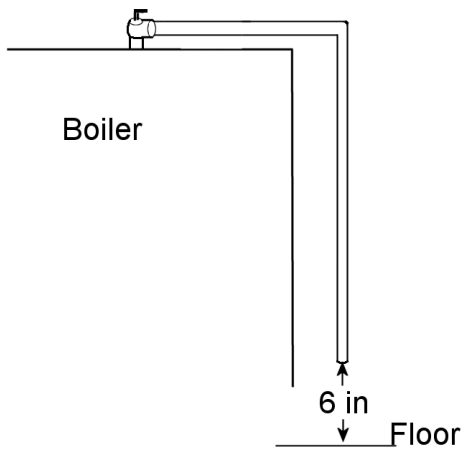

Pressure Relief Valve

Note: A length of copper pipe must be connected to the pressure relief valve continuing to a point 6 in from the floor as shown in Figure 3 above.

The purpose of extending the pipe to the floor is to direct any blowout of scalding water downward instead of outward. This reduces the likelihood of exposing bystanders to a scald hazard.

Pressure Reducing Fill Valve

If the Wood Gun™ is installed as the primary boiler, it is necessary to provide for water supply using a pressure regulating valve and backflow prevention valve in the feed water line.

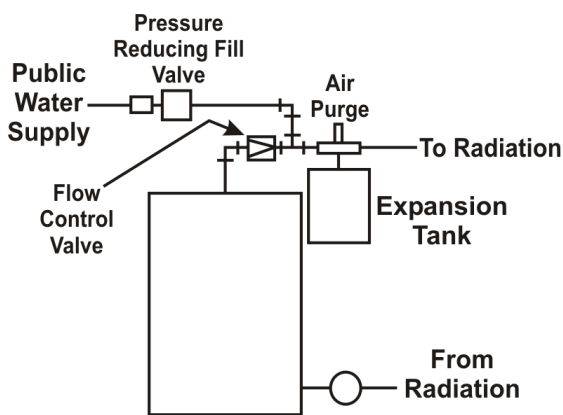

Pressure regulating valve and backflow prevention valve configuration

Expansion Tank Selection

Closed loop systems require the use of an expansion tank. Refer to Appendix A: Additional

Specifications to determine the water capacity of the Wood Gun™ installed (do not use the BTU rating). The expansion tank or air cushion tank that was originally installed will not likely be adequate for the additional volume of water added to the system with the inclusion of a Wood Gun™. The tank must be sized based on total water volume and the difference between the low and high temperatures of this water. When properly sized, it will accommodate the thermal expansion of the water being heated without creating an overpressure situation. Some closed loop systems are isolated from an open (atmospheric) side of the system, or another closed loop, by a heat exchanger. For calculating system volume, only the volume in each respective closed loop is calculated, with each closed loop receiving its own dedicated expansion tank capacity. If the autofill valve engages and adds water to the system when cold, and the boiler subsequently builds too much pressure when hot, you do not have adequate expansion capacity.

▲ CAUTION	
	PROVIDE ADEQUATE EXPANSION TANK
It is very important to provide adequate expansion tank capacity based on the total volume of water in the system, particularly when the Wood Gun™ is added to an existing boiler.	

Return Water Temperature

RETURN WATER TEMPERATURE

As a rule, water returning to the boiler should be not more than 20° F less than supply water temperature going to the system. A recirculation loop is a requirement to maintain optimum return water temperatures. This would optimally include a thermometer on the return line entering the boiler for monitoring purposes, and a mixing valve to maintain minimum return water temperatures. Return water temperature near or below 140° F

creates the risk of severe condensation issues. This will often produce unpleasant odors and possible liquid runoff in the boiler room. More seriously, it will lead to creosote formation on heat exchange surfaces and inside the chimney, with accompanying risk of a chimney fire.



View the following diagram for a sample piping layout utilizing a mixing valve on the boiler return. The mixing valve shown is a cartridge type. Water temperature is regulated by the use of a specific cartridge installed in the valve to control temperature of the water returning to the boiler.

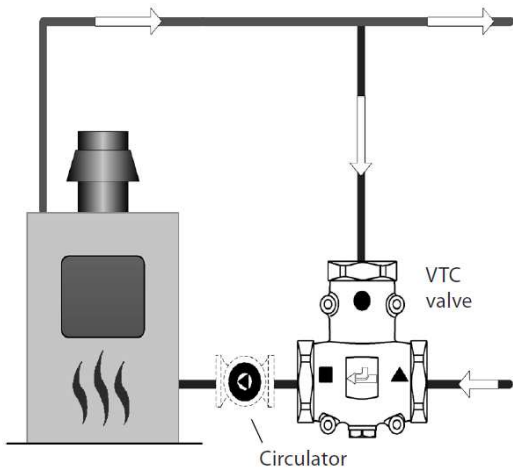

Three Mixing Valve: Return Water Protection

Low Water Cutoff



Photo: Low Water Cutoff Installation

The low water cut off should be installed in the supply riser just above the tapping of the boiler, as shown above. Place a Tee fitting 6" above the boiler in the supply line. Install the L.W.C.O. so that it is accessible and the indicator lights can be seen.

Run three wires from the L.W.C.O. to the main control box that corresponds with the wires/terminals in the control box. The wires needed are: Orange, Orange #2, White. These wires will terminate in the LWCO as follows:

1. The orange wire will be terminated with the black wire and one of the Yellow wires.

2. The orange 2 wire will terminate with the remaining yellow wire.

3. The White or neutral wire will terminate with the white wire in the LWCO.

Terminate the wires in the control box with the corresponding wires (or terminal blocks that correspond with the wire).

1. The Orange wire will terminate on the terminal marked orange.

2. The Orange #2 wire will terminate on the terminal marked orange #2.

3. The White wire will terminate on the terminal marked white, L2 or neutral.

RECOMMENDED BOILER CONTROL SETTINGS IN HYDRONIC SYSTEMS

The following control settings are recommended for parallel installations:

- ✓ High limit 200° F
- ✓ Operating control on the rear of the boiler is 180°.

Set the operating control differential set to 15° F unless using cast iron radiators, for which a differential setting of 20° F or more is recommended.

Additional settings may include:

- ✓ Optional circulator shutdown control 160° F
- ✓ An existing oil/gas boiler 140° F.

On Wood Gun™ models equipped with oil or gas backup, the control settings should be as follows:

- ✓ High limit = 200° F
- ✓ Operating Limit = 180° – 170° F
- ✓ Burner Control (L6006A) = 150° F

In this way, the oil burner will function as a backup and only fire when the boiler temperature drops below about 150° F. The oil burner may be set even lower if desired to prevent it from firing except when the wood fire is almost completely out.

Wood Gun™ units supplied with automatic switchover (fuel oil only) are provided with a mode switch. When turned to either the “Wood” or “Oil” mode it will fire on the indicated fuel and not switch over. In the “Auto” position it will change from the wood mode to oil when the water temperature falls to the setting on the switchover aquastat (L6006A), and will stay in this mode until manually reset, at which time the boiler may be refueled with wood.

For units equipped with electric backup, follow the procedure outlined above with the exception that one of the electric element aquastats should be set about 5° F higher than the other. This will prevent all electric elements from being activated at the same time.

BOILER CONDITIONER / SEALANT

AHS provides two bottles of Boiler Conditioner/Sealant with the purchase of your boiler. When filling your boiler with water for the first time, mix the contents of each bottle with 2 gallons of warm water. Pour into boiler opening. Replace plug. A Material Safety Data Sheet (MSDS) is available upon request.

BOILER PIPING AND CONTROLS FOR LOW PRESSURE STEAM SYSTEMS

Wood Gun™ models E180 and larger are available with steam tappings and controls by special order. When installing a low-pressure steam boiler, be sure that the installation conforms to all state and local codes. All steam boilers will be supplied with a low water cut-off, which fits the ¾ inch tapping on the rear of the boiler. This control must never be hot wired or disconnected since it prevents the boiler from firing should the water level drop below the safe operating level.

A water level gauge glass is also provided to give a visual indicator of the level of water in the boiler. This gauge is located in tapping FF on the rear of the boiler and a section of piping, which originates from a tapping in the top of the boiler near the rear.

An automatic water feeder or combination water feeder/low water control such as a McDonnell-Miller model 47-2 is required to ensure that the proper water level is maintained. Some states or municipalities require two low water control devices in series. The two controls described above will meet this requirement.

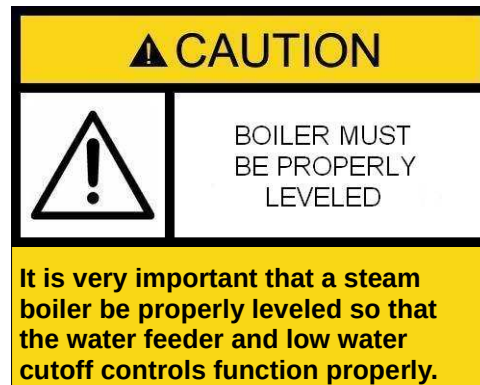

For steam systems other than gravity return consult Alternate Heating Systems for proper controls. Do not attempt to connect two different steam boilers in parallel since the water level in each boiler will not be the same.

Note that steam models are wired differently than hydronic models. See Appendix B for Wood Gun wiring diagrams. Contact Alternate Heating Systems if you need a diagram not included in this manual.

**FORCED HOT AIR SYSTEMS
(WATER TO AIR COIL IN DUCT)**

The Wood Gun™ boiler may be easily adapted to any forced hot air heating system by installing a heat exchange coil in the supply duct. The size and type of coil required may be determined after several factors are determined. These factors include: the heat output required (BTUH), the capacity of the existing fan blower (CFM) and the size of the duct or plenum where the coil will be installed.

The coil creates increased resistance to air flow, so this factor must be considered when determining the final airflow. Design water temperature is usually 180° F and a desirable output air temperature is 115° - 125° F.

Tip: To increase coil performance, increase boiler water temperature.

The coil is connected in the same manner as in other types of radiation heating equipment. The thermostat should be wired to both the fan blower and the circulator pump or a temperature-sensing switch on the heat exchange coil. If a hole was cut in existing ducting to install the coil, the opening should be closed tightly with a metal cover and sealed with duct tape.

**DOMESTIC HOT WATER
COIL PIPING**

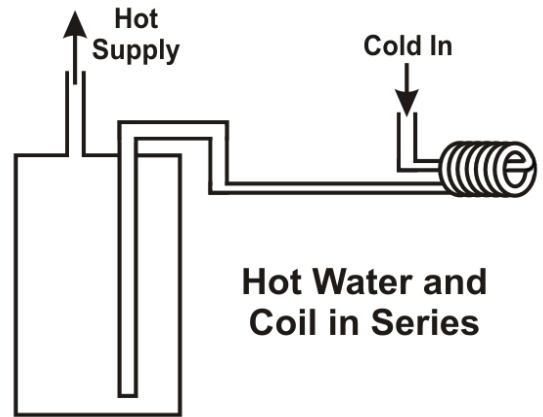

Plumbing – Coil in Series

The Wood Gun™ may be fitted with one or more domestic hot water coils, which thread into 4 inch tapping's in the boiler. There are three methods for plumbing the domestic coil. One way is to connect the coil in series with an existing hot water heater.

A second method of plumbing the domestic coil is to connect the coil in parallel with an existing water heater so that the conventional water heater may be used when the Wood Gun™ is not being fired (for example, in the summer). The diagram below indicates how this can be done.

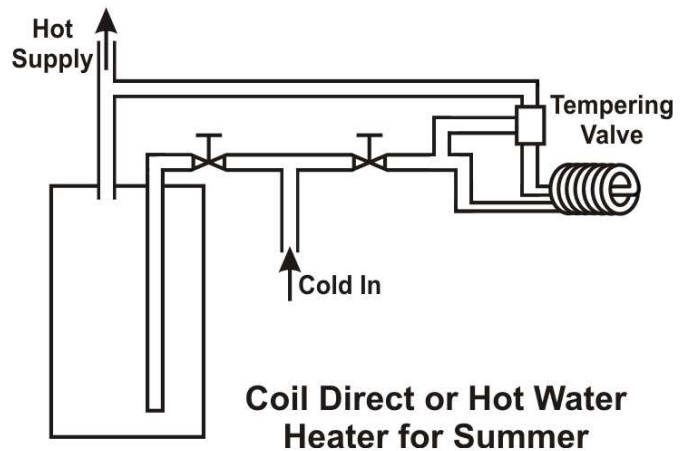

Plumbing – Coil in Parallel

⚠ CAUTION	
	BURN HAZARD
<p>In installations where the coil discharges directly into the hot water distribution system a tempering valve must be included to limit the temperature of the water at the faucet to a safe level.</p>	

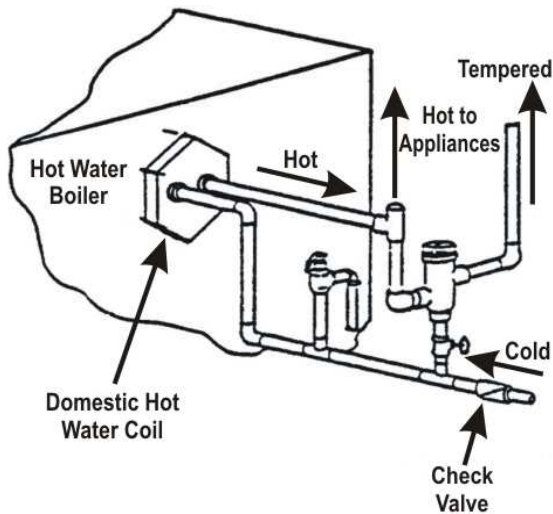
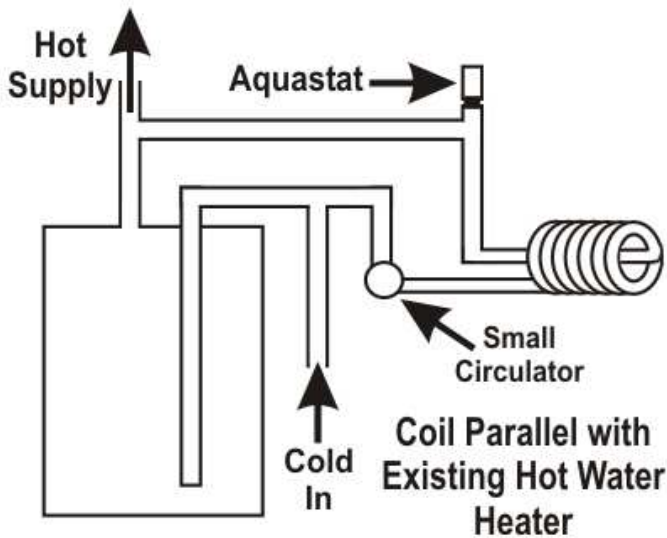

Figure: Domestic Coil Tempering Valve



Plumbing – Coil with circulator

OIL BURNER ASSEMBLY

General Information

If an oil burner is supplied with the Wood Gun™, connection of fuel lines and the adjustment of the burner should be done by a qualified oil burner technician. The oil burner is normally shipped detached from the Wood Gun™ in a separate box. Refer to the Riello Burners Installation Manual included with your shipment for instructions on configuring the burner. Particular attention should be paid to the Oil Line Connections section of the Riello Installation Manual. Ensure that the correct size nozzle is in place on the burner before installing on the boiler. The correct nozzle size for the Riello Oil Burners installed in the E155 is 0.65 gph, 45°, semi-solid.

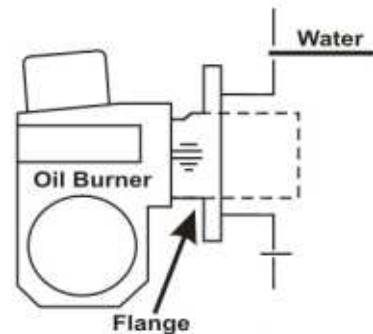

Bolt the mounting flange into place using 4, 3/8 inch nuts, washers and lock washers. Ensure that the gasket that is furnished with the burner is placed between the flange of the Wood Gun™ and the mounting flange of the oil burner to prevent air leakage.

Oil/Gas Burner Combustion Chamber: Models E155

Wood Gun™ models E100 and E140 have an optional oil burner combustion chamber, which is exterior to the boiler and located on the right hand side of the boiler when viewed from the front. To mount the combustion chamber, apply the enclosed piece of 1/8 in x 1/2 in self-stick silicone strip to the combustion chamber flange just inside of the bolt holes. Attach the combustion chamber to the flange on the boiler using three 5/16 in x 1 in bolts and

washers. The metal jacket cover and insulation on the combustion chamber must be removed to gain access to the holes in the flange as shown below.

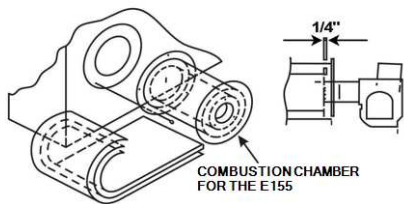

E155 Combustion Chamber

After securing the combustion chamber to the boiler, replace the insulated jacket. The burner mounting flange should be bolted to the end of the combustion chamber using four 3/8 in x 1 in bolts. The burner should be positioned so that the end of the air tube is back approximately 1/4 in from the inside of the ceramic lined chamber (see Figure 10)

Oil Burner Electrical Connection

Connect the burner in accordance with wiring diagrams found in Appendix B: Wiring Diagrams. The (T) terminals on the protector relay of the oil burner may need to be crossed with a jumper wire to activate the burner on certain models. The Aux (auxiliary) wire may not need to be terminated.

Oil Burner Fuel Line Connection

The fuel lines should be connected using copper flare fittings or threaded pipe.

▲ CAUTION	
	DO NOT USE COMPRESSION FITTINGS TO CONNECT FUEL LINES
Never use compression fittings to connect the fuel lines, since they have a tendency to vibrate loose during operation.	

Oil Burner Adjustment

For proper oil burner adjustment, refer to the burner installation manual.

Note: If the oil tank has a two-pipe system, then it is necessary to insert the bypass plug into the burner pump as described in the manual for the oil burner. When using a Riello Burner, always use a two-pipe fuel line system.

Designing a multi-fuel boiler to burn both wood and oil/gas efficiently presents several problems not normally associated with a conventional oil or gas boiler. Wood combustion produces ash, which has a tendency to accumulate on all exposed heat exchange surfaces. Another significant factor is the presence of water, which must be evaporated from the fuel and carried out of the boiler in the exhaust gas stream. In addition, products of incomplete wood combustion, which result from initial start-up, re-ignition after a long "off" cycle, and inadequate or infrequent cleaning, will be deposited within the unit.

Every oil burner contains safety devices that are designed to prevent unsafe operation. When the burner is activated, fuel is pumped through the nozzle in the presence of an ignition arc produced by two electrodes and a high voltage transformer. In order to prevent raw fuel from being discharged into the combustion chamber should ignition fail to occur, a CAD cell is employed to "proof" the flame. If the CAD cell does not "see" a flame within a preset time period, usually 20-30 seconds, a relay will shut down the burner and it cannot attempt to re-fire until the reset button is pressed. When contamination from the wood combustion process coats the CAD cell it interferes with the proper functioning of this safety device.

If the Wood Gun™ is properly cleaned and maintained on a regular basis, then the adverse effects described above are minimized. However, neglect of the unit may result in disappointing performance. It is recommended that in instances

where the owner intends to depend upon the oil burner as the primary fuel source, that the oil burner be cleaned and test fired several times to verify that the safety control system is not impaired. If wood is the primary fuel source, with oil a seldom used backup, Alternate Heating Systems strongly recommends the unit be fired on oil periodically to assure that the oil burner will function when needed.

Do not assume that a unit operated solely on wood for an extended period of time will fire on oil without attention.

Note: It is a good idea to test fire the oil burner when weekly cleaning and maintenance is performed.

In all Wood Gun™ models, the draft-inducing fan increases the air velocity past the nozzle. Because of this increased air velocity, the Burner Adjustment Tables in the Riello manual are a good starting point for initial firing of the burner; however, fine-tuning of the burner settings is usually needed.

For proper burner adjustment a combination test kit must be used. It is not likely that the CO₂ levels suggested in the burner manual can be achieved, but the net stack temperature will be very low, yielding a net efficiency well in excess of 80 %. Refer to the burner manual for information regarding wiring logic and individual components of the burner.

GAS BURNER ASSEMBLY

Refer to the Riello Burners Installation Manual included with your shipment for instructions on configuring the burner. Gas burners must be installed utilizing manual switchover controls only.



NOTE: The Riello gas burner has an air sensor that senses airflow through the burner. When a Riello gas burner is installed, then a variable speed induction fan control may need to be a necessary option.

The burner mounts to the flange on the boiler combustion chamber using three 3/8 in x 1½ in bolts provided. Make sure the gasket provided with the burner is placed between the flange on the Wood Gun™ and the mounting flange of the gas burner. Connect the burner according to the wiring diagram included with your boiler or found in Appendix B: Wiring Diagrams

For larger units consult the special instructions provided in the supplement to this manual.

Before allowing gas that is under pressure into the piping, all openings from which gas can escape should be closed. Immediately after turning on the gas, the system should be checked for leaks. This can be done by watching the ½ cubic foot test dial and allowing five minutes to show any movement or by soaping each pipe connection and watching for bubbles. Use a solution of dishwashing detergent and water for “poor man’s” leak detection or use electronic detectors. Pay attention to any gas odor and follow up any observed odor with a check of all connections for leaks. Remember that ventilating an area when correcting a leak is normally a good idea. Keep in mind that propane is heavier than air and natural gas is lighter than air.

Note: Advice offered in this manual is NOT a substitute for securing the services of a professional installer.

Consult the burner manual for the proper procedure for purging air from the system and for initial start-up of the burner.

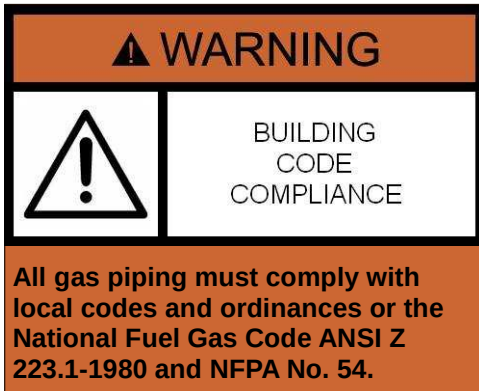

Gas Burner Adjustment

Please see the Riello Burner Installation Manual section entitled Setting up the Burner for information on gas burner adjustment.

OIL AUTOMATIC SWITCHOVER AND LOCKOUT CONTROL

The Automatic Switchover option automatically switches the Wood Gun™ into oil mode if it is unable to maintain temperature while firing with wood. The most likely scenario causing the switchover to take place is when the boiler has used up the wood fuel. The Wood Gun will also switchover to oil if the fire goes out, as may occur when the boiler has been inactive for hours, and the refractory has cooled to below the kindling temperature for wood. In this case, the boiler must be manually switched back to wood mode, and manually relit, in order to resume wood burning.

The Lockout feature prevents needless cooling from the induction fan running while in oil mode. Once this feature is engaged, the boiler switches to oil mode and will function continuously as an oil-fired boiler until manually switched back to wood mode. Automatic switchover is not available for use with gas backup. See Appendix B for wiring logic for units equipped with this feature.

SMOKE FLAP

The smoke flap must be installed before operating the boiler.



Photo: (Smoke flap)

The smoke flap will help hold back some of the smoke when the front load door is opened, and provide some protection against flashovers in the fuel chamber.



Photo: (Smoke flap installed)

Operating Information

Please read this entire manual before operating the boiler. It contains important requirements and instructions must be followed for safe and satisfactory operation of the boiler.



All cover plates, enclosures and guards must be maintained in place at all times, except during maintenance and servicing. Always keep fueling and ash doors closed when the boiler is not being tended. Always maintain all seals in good condition.



Be sure the boiler vessel is full of water and pressurized before starting a fire. Never attempt to add water to a hot boiler if found to be only partially full. Allow the unit to cool before adding water to the boiler. Failure to do so could result in death or severe injury along with damage to boiler and surrounding property.

The bottom of the fuel chamber contains dense cast refractory blocks. The refractory is baked in a kiln at the factory to dry out nearly all moisture before it is placed in the boiler, but it does not reach maximum strength unless heated to operating temperature gradually (cured).

NOTE: It is recommended that several small charges of wood be used initially to ensure that maximum durability of the refractory lining is achieved.

On units that have a backup oil or gas burner, the green indicator light will only be on when the fan is running and the oil burner is not firing. If the

indicator light does not come on when the purge timer is activated, it means the oil/gas burner is firing and **the door must not be opened.**



The green light at the upper left corner of the boiler indicates when the draft-inducing fan is running. The only time the load door can be safely opened is when the indicator light is on. If the indicator light is off, turn the purge timer clockwise to number 5 and wait two minutes before opening the door slowly. The waiting period will allow sufficient time for the fire to become re-activated and burn off any gases that may have collected in the fuel chamber during the off cycle.

Once the Wood Gun™ has switched automatically or has been manually switched to a backup fuel, switching back to wood must be performed manually. This is accomplished by shutting the main switch off, turning the fuel selector switch back to wood, turning the main switch to on, and rekindling the boiler in the same manner as when the boiler was initially fired with wood. Be sure to only open the door when the green light is on. In order to permit the unit to continue firing in the wood mode, it cannot be switched to the “auto” position until boiler temperature has exceeded the setting of the switchover aquastat.

⚠ CAUTION

BURN HAZARD

Do not remove the smoke flap in the loading door while the Wood Gun™ is being fired. It is there for your protection and removing it may expose the operator to flashback under certain conditions. If the smoke flap is removed for cleaning or inspecting the refractory, be sure to put it back in place.

⚠ WARNING

DO NOT OPERATE DURING POWER FAILURE

Do not open the doors or operate this unit during a power failure.

STARTING A FIRE: SWITCH POSITIONS

Switch Positions: Cold Boiler Start-up

	Before Lighting	After Lighting	Water Temp Risen above 150°
Boiler Switch	Off	On	On
Start/Run Switch*	Start	Start	Run

*Units with Low Temp Shutdown only

⚠ DANGER

NEVER USE FLAMMABLE LIQUIDS TO START FIRE

Never use chemicals or flammable liquids to start the fire. DO NOT burn garbage or any other fuel not approved for this unit.

FUEL TYPE

The Wood Gun is designed to burn split or unsplit wood

The Wood gun is designed to burn log wood. The Wood gun is able to burn both hard wood and soft wood fuel. Keep in mind that hardwood is typically a better fuel. Hardwood will usually give you longer burn times than softwood, due to greater energy density per unit volume. Oak, Maple, and Cherry are a few of the hardwood types that can be burnt. Cedar fir and pine are a few of softwood species that can be burnt. A well managed Wood Gun will not produce creosote from burning softwood.

STARTING A FIRE: PROCEDURE

Starting a fire in the Wood Gun™ is similar to starting a fire in any wood fired boiler with a few important differences. Because the Wood Gun incorporates a downward draft, successful fire starting requires recognizing that fact and layering kindling accordingly. Place kindling wood on the refractory in a lengthwise orientation. Add a layer of crumpled up newspaper followed by another small layer of kindling. Light the paper. Turn on the boiler switch. When the kindling is burning well, add more (and larger) pieces of wood.

Note: Always place wood in the Wood Gun™ lengthwise (from front to back). Never place wood in the fuel storage area crosswise.

When firing a cold boiler, it is important to concentrate heat next to the refractory. The Wood Gun™ depends on high refractory temperatures for driving the gasification process. Using drier, smaller wood will help to accomplish this. Add larger pieces only after the fire is well established. Only fill the fuel storage area after the refractory has reached good gasification temperatures. Keep in mind that a small intense fire is preferable to a large smoldering one to reduce the amount of creosote deposition. This will be accomplished by building the initial fire with wood no higher than the door frame. When the starting charge is burning hot, add the rest of the

charge in sufficient quantity to last for up to ten hours. Longer cycles are possible, but you will want to plan for utilizing shorter burn cycles periodically to provide for good firebox management. Best practices include keeping ash and charcoal build-up to a minimum. When demand is moderate to low, simply load charges of fuel that are just adequate for the length of the anticipated burn cycle.

SEQUENCE OF OPERATION

The boiler regulates itself to operate in an efficient manner and at the same time be able to keep up with high demand situations. The boiler will shut down at 180F. It will sit dormant until enough demand is used to drop the water temperature to 165F. At that point the boiler will turn on. The actuated damper will begin to open and the blower motor will turn on. The unit will operate on high for three minutes at which point it will reduce the motor speed to normal. If at any point the boiler temperature falls below 152F the blower motor will switch into high. The unit will continue to operate in this fashion until it overcomes demand and shuts down at 180F. If the boiler is equipped with the Low Temp Shutdown option the unit will shut down because of low water temperature at 140F.

A manually operated damper located at the rear of the unit can be temporarily closed in a proportional fashion to slow the burn rate of dry wood. Be sure to read the section on dry fuel, and about the EPA Side Tunnel Plug, a little further in the manual.

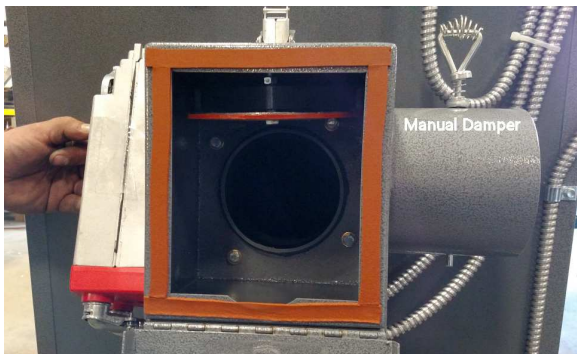

Automatic and Manual Dampers

Charging the Boiler with Wood: Manual Feed



When it is time to reload the Wood Gun™, note the indicator light above the purge cycle timer. If the indicator light is off, push the green Purge button or turn the purge timer clockwise to number 5 and wait two minutes before opening the door. Open it slowly by cracking it open just a bit to allow air to flow in smaller quantities through the opening. After 5-10 seconds, you may open the door fully. This waiting period will allow sufficient time for the fire to become re-activated and burn off any gases that may have accumulated in the fuel chamber during the off cycle. Even if the green light is on, **open the door cautiously**, since abruptly introducing air over the glowing fuel particles may cause it to temporarily flame up.

When reloading the Wood Gun™, it is a good idea to use the ash rake to make sure that all of the center slots are open and free from ash and charcoal before adding more wood. Such raking is required more often when using softwood, or any wood with a high ash content. Wood bark has a very high ash content relative to the centers of wood pieces. When using hardwood, clear the slots at least daily. Clear the slots by raking charcoal pieces away from the slots. After raking the charcoal pieces away from the slots, rake ash into the slots, thus aiding the process of allowing the induction fan to pull the ash through. A vacuum that is rated for ash removal can also be used for removing ash that does not contain live embers.

Note: Spent ash should not be allowed to build up on or in the refractory. Any ash buildup will insulate the fuel charge from the heat generated in the refractory, slowing the rate of gasification, and thereby reducing heat output.

Best results with fuel loading will be obtained if the charge of wood is limited to the amount needed to produce a 10-hour burn under anticipated heat load conditions. Adding more wood than can be utilized in 10 hours will likely lead to charcoal buildup and potential issues with “back puffing”. The reason for this is that moisture is being evaporated from the fuel during the off cycle by heat radiating from the refractory. During the course of several hours of intermittent burning the entire fuel charge will have been dried down so that gasification can occur at a very rapid rate when the unit resumes active firing. Under these conditions there may be insufficient oxygen present to adequately burn all the gas, which results in limited to extensive (and repeated) back puffing.

Long burn cycles will also lead to accumulation of charcoal in the fuel storage area. Excess charcoal will tend to block airflow through the slots in the center brick. Furthermore, soft, crumbly charcoal can also be pulled through the refractory, resulting in tiny, live embers being emitted into the cyclone.

Note: Guard against charcoal accumulation in your Wood Gun™ by keeping burn cycles at less than 10 hours. Utilize occasional short cycles, as short as 4 hours, for good firebox management.

Very dry wood of 18% moisture content or less, or fuel with a lot of surface area per volume such as slab wood or kiln-dried scrap from manufacturing, is likely to produce back puffing as well. The optional secondary draft tube is one option to help alleviate this problem when burning wood that is very dry. Preferred options follow, as included in this backpuffing prevention/resolution checklist.

Back-Puffing Prevention Checklist

- ✓ Use fuel with higher moisture content,

- ✓ Load wetter fuel on the top of your fuel charge
- ✓ Use a good percentage of full rounds, as large as 10 inches or more in diameter
- ✓ Stack wood tightly, using a combination of full rounds and split pieces to form a more solid block of fuel inside the fuel chamber
- ✓ Utilize shorter burn cycles, to prevent over drying of the fuel charge that occurs with long cycles
- ✓ Use the EPA Side Tunnel Plug (described below)

One way to appraise what is going on inside the boiler is to open the air valve box during an active firing cycle (or to look through an optional Air Valve View Port) and observe the fire. If you see flames shooting upward inside the fuel chamber, consider the above checklist items as your action list for preventing back puffing. Remember, the Wood Gun utilizes a down draft design, and optimum combustion takes place when the flame is properly inverted.

EPA Side Tunnel Refractory Plug

This plug fits into one of the side refractory tunnels, blocking passage of hot combustion gasses. This results in one side of the refractory lining the bottom of the fuel chamber remaining comparatively cooler than the other. Less heat on that side means a lower rate of pyrolysis, and lower total amounts of wood gas production. If not in place unwanted backpuffing, and lengthened warm up times may occur.



EPA Side Tunnel Plug



EPA Side Tunnel Plug Install

Note: When starting a fire in a Wood Gun™ equipped with an oil or gas burner, it is first necessary to switch the fuel selector control to “wood” mode.

WOOD FUEL CHARACTERISTICS AND WOOD STORAGE

Although the boiler will burn green or wet wood, this practice is discouraged because of the substantial amount of heat energy required to evaporate the moisture before combustion can take place. When first cut, the moisture content of wood may range from 40% to 60% as compared with air-dried wood at 25% to 35%. Each extra 25% of moisture represents approximately five gallons of additional water that must be evaporated and passed out the chimney for each 160-pound charge of wood. The heat that must be used to evaporate any extra water is heat that is then not available for your heating application, lowering significantly the maximum heat output of the boiler. It is advantageous to let the sun remove that extra 100 to 250 gallons of water found in a cord of wood. Generally, wood should be stored outdoors

in a dry place with only a limited supply kept indoors.

Using wood that has a moisture content of greater than 30% can be detrimental to the operation of the boiler. Results of using wood with too high of a moisture content are likely to include loss of BTU output, reduced efficiency, and condensation issues. Using high moisture wood will reduce the service life of carbon steel boilers. It is recommended to have at least one week worth of fuel inside and kept out of the weather. Do not store fuel within the appliance installation clearances or within the space required for fueling, ash removal, and other routine maintenance operations.



Do not store wood within the recommended clearances of the boiler or within the space required for loading wood and ash removal.

LOW WATER TEMPERATURE OPTION

When the Low Water Temperature Shutdown (LTS) switch is in the “ON” position the low temperature function will allow the boiler to operate normally until the water temperature falls below the set point of the LTS aquastat (located at the rear of the unit). The factory setting on this aquastat is 145F. When the boiler water temperature is at or below the set point the boiler will shut down. The reason for this is to keep the boiler from cooling the system down when the boiler is out of fuel. When the boiler is running with no fire the cool air moving through the unit will cool the water. This is especially inefficient if there is a backup boiler (in most cases oil or gas fired) is trying to maintain heat in the system.

When it is time to start the boiler, load the boiler as you would for a normal start. When it is time to have the draft fan turn on, simply push the black start button. The start button will activate the boiler and will allow the unit to run for two hours while below the LTS set point. Within these two hours the boiler will be able to heat up enough to raise the water temperature above the LTS set point. At no point does this function override any other limit controls on the boiler. If with the two hour time limit the boiler water temperature would reach the operating set point the boiler will shut down as normal.

COOL DOWN CYCLE

The Wood Gun is to run a cool down cycle. When the boiler is operating for a period of six minutes or more, the fuel inside will begin pyrolysis. In the design of the Wood Gun, the boiler will use this process to produce heat efficiently. When the boiler reaches the operation temperature limit, it will shut down and enter into a dormant state. At this point, there are combustible gases in the fire box. Allow the Wood Gun fifteen minute cool down cycle. The cool down cycle begins as soon as the boiler shuts down and should last for fifteen minutes. During this period, the boiler should be started.

WOOD FUEL CHARACTERISTICS AND WOOD STORAGE

Although the boiler will burn green or wet wood, this practice is discouraged because of the substantial amount of heat energy required to evaporate the moisture before combustion can take place. When the first cut, the moisture content of wood may range from 40 to 60% as compared with air-dried wood at 25% to 35%. Each extra 25% of moisture represents approximately five gallons of additional water that must be evaporated and passed out of the chimney for each 160 pound charge of wood. The heat that must be used to evaporate any extra water, is heat that is then not available for your heating application. This significantly lowers the maximum

heat output of the boiler. It is advantageous to let the sun remove that extra 100 to 250 gallons of water found in a cord of wood. Generally, wood should be stored outdoors in a dry place with only a limited supply kept indoors.

Using wood that has a moisture content of greater than 30%, can be detrimental to the operation of the boiler. Results of using wood with too high of a moisture content are likely to include loss of BTU output, reduced efficiency, and condensation issues. Using high moisture wood will reduce the service life of carbon steel boilers. It is recommended to have at least one week worth of fuel inside and kept out of the weather. Do not store fuel within the appliance installation clearances or within the space required for fueling, ash removal, or other routine maintenance operations. The EPA has made available a few videos to help you understand what fuel is best and why. These videos can be viewed online at the following addresses:

EPA Burnwise Program:

<http://www.epa.gov/burnwise>

How to use a Moisture Meter Video:

<http://www.youtube.com/watch?=jMsWGgRcnm0>

Wet Wood is a Waste Brochure:

<http://www.epa.gov/burnwise/pdfs/wetwoodwastebrochure.pdf>.



REMOVAL AND DISPOSAL OF ASHES

Ashes should be placed in a metal container with a tight fitting lid. The closed container of ashes should be placed on a non-combustible floor or on

the ground well away from all combustible materials, pending final disposal. If the ashes are disposed of by burial in soil or otherwise locally dispersed, they should be retained in a closed container until all cinders have thoroughly cooled to prevent inadvertently starting a fire.

CONDITIONING OF BOILER WATER

Note: The guidelines in this section are to be used in conjunction with the advice of a water treatment specialist.

Proper treatment of feed water and boiler water is necessary to prevent deposits and corrosion within the boiler. The neglect of adequate external and internal treatments can lead to operation faults or total boiler failure. Where a choice is available, pretreatment external to the boiler is always preferred and more reliable than treatment within the boiler.

Instructions for feed water treatment as prepared by a competent feed water chemist should be followed. Do not experiment with homemade treatment methods or compounds.

Representative samples of feed water and boiler water need to be analyzed frequently to ensure that they are within specified ranges.

Strict monitoring of boiler water is more important for steam applications (and for open systems) where there is a continuous influx of makeup water. For hydronic units, typical installations utilize the boiler water in a closed system, which only occasionally requires the addition of makeup water over the lifetime of the boiler.

Note: For hydronic situations where the system is not closed, the following water treatment guidelines still apply and become even more critical!

pH

The pH value of your boiler water is a number between zero and fourteen. Values below seven are acidic while values above seven are basic.

The pH factor is the most important factor influencing scale forming or the corrosive tendencies of boiler water. It should be adjusted to between a minimum of 9.0 and 11.0 to prevent acidic corrosion of boiler tubes and plates and to provide for the precipitation of scale forming salts.

Below a pH of 5.0 the water is acidic enough to dissolve the steel boiler plates. Under these conditions the steel gradually becomes thinner and thinner until it is destroyed. At a pH between 5.0 and 9.0 pitting of steel plates is likely to occur at a rate dependent upon the amount of dissolved oxygen in the boiler.

Dissolved Oxygen

Aeration of city water supply is frequently used to remove noxious gases, however, aeration results in saturation of the water with oxygen. A majority of corrosion problems are directly related to the quantity of dissolved oxygen in the boiler water. Elimination of the corrosive effect of dissolved oxygen can be accomplished either directly or chemically.

Direct or mechanical removal of dissolved oxygen is done through the use of a de-aerator. Chemical de-aeration is done through the introduction of specific chemicals in the boiler to react with the oxygen. The dissolved oxygen content should be maintained at a minimum but at no time should it exceed 0.007 mg/l.

Sodium sulfite is commonly used for the chemical removal of dissolved oxygen within the boiler water. To assure the rapid and complete removal of the oxygen entering the boiler feed water system the concentration of sulfite in the boiler should be maintained at a minimum of 120 ppm.

Solids (Primarily for Steam Boilers)

High boiler solids will lead to foaming, priming, surging, carry over or boiler sludge in steam boilers. Occasional blow downs of the boiler may remedy these conditions. We recommend you utilize the services of a local professional plumbing service for this boiler maintenance task.

(See <http://www.p2pays.org/ref/34/33027.pdf>)

Solids can be categorized as either suspended or dissolved. Suspended solids are those that can be removed by filtration while dissolved solids are in solution with the water.

The best way to determine the dissolved solid content of boiler water is a conductance test. The conductance of boiler water varies proportionately with the amount of various ionized solids present.

Another way to determine the dissolved solids content is to measure the chlorides present in the boiler water. The chloride test is less sensitive than the conductance test for measuring small concentrations of dissolved solids. The results of both tests should be averaged for accuracy.

Alkalinity

The alkalinity of boiler water should be sufficiently high to protect boiler steel against acidic corrosion, but not so high as to cause carryover

(basic) corrosion. A minimum value for alkalinity for adequate protection is 200 ppm CaCO₃.

High boiler alkalinity (in excess of 700 ppm CaCO₃) should be avoided. Values higher than this can cause the steel to become brittle.

Phosphates

Phosphates are used to counteract hardness in the boiler water. It is important to maintain a pH of at least 9.5 to not hinder the reaction of the phosphates with calcium hardness. Try to keep the concentration of phosphates in the water to 30-50 ppm to enable complete reaction.

Hardness

The hardness of water is caused by calcium and magnesium ions. Water hardness will vary greatly throughout the country depending on the source of the water. In boilers, hard water can cause the formation of scale and sludge or mud. Total hardness should not exceed 50 ppm.

Oils

Every effort should be made to prevent oils from getting into the boiler water. Oil causes foaming or combines with suspended solids to form a sludge, which can cause the overheating of boiler plates. If oil does get into the boiler, the boiler should immediately be taken out of service and thoroughly cleaned.

Maintenance

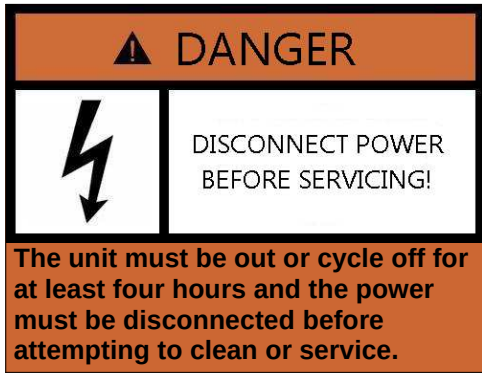

It is important to establish a routine for the storage of fuel, starting the fire, and caring for the unit so as not to overlook important aspects of safety, and to maintain the unit in optimum condition. Maintaining the load door seal and air valve gasket seal are very important for efficiency, and for safety.

WEEKLY CLEANING PROCEDURE

Following is the recommended procedure for weekly cleaning:

1. Open front inspection door.
2. Place an ash receiver under the refractory at the front inspection door opening.
3. Use the ash rake to pull the ash from the center tube.
4. Inspect the outside refractory tunnels for ash buildup and remove with ash rake if necessary.
5. Inspect the refractory center plug that is inserted in the front of the combustion chamber (center refractory tube) and verify that it properly seals the front access opening.

Note: The front of the center combustion chamber must be properly sealed to prevent gas from being drawn directly into the heat exchanger thereby bypassing the refractory tunnels.

6. Use a putty knife or scraper to clean ash from the bottom of the door openings.
7. Scrape condensation and creosote build-up from inside the air intake manifold using ash rake.

On models with dual draft, use a putty knife or scraper inside the firebox.

8. Open the draft valve cover and inspect the valve gasket disk for evidence of air leakage. The disk should have some wobble, so it can move and find its own seal. See “**Air Valve Cleaning and Maintenance**” below.

9. Inspect the fuel chamber and remove any ash residue. Pay special attention to corners as ash can easily become trapped here.

10. Remove ash pan from the cyclone separator and dispose of its contents.

11. Clean excessive ash out of fire box.

Air Valve Cleaning and Maintenance

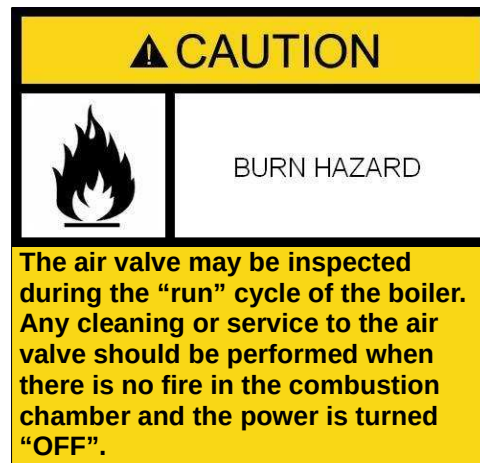

To Operate the Air Valve Manually for Cleaning and Service:

1. Insert supplied hex key wrench in center as shown in photo.
2. Rotate in the direction indicated on cover.
3. When opened to the desired position, hold the hex key wrench to prevent the spring return from moving actuator.
4. With the hex key wrench held in place, use a screwdriver to turn the gear train lock pin in the indicated direction. Slowly allow the hex key wrench to rotate backwards until the detent is reached. At the detent position, the pin will lock the motor in

place. In the locked position, cleaning and or replacement of the air valve disc can be performed.

5. To release the actuator, use the hex key wrench and rotate in the open direction $\frac{1}{4}$ turn. The lock is spring loaded to release. Remove the hex key wrench and allow the valve to close.

The air valve should be inspected and cleaned weekly to ensure that it is sealing properly. A leaking air valve or load door can produce a number of undesirable consequences, including a low smoldering fire. When the air valve is open and the unit is operating, moisture released from the fuel will condense when contact is made with cooler combustion air. Moisture and creosote can collect on the gasket disk and on the end of the air valve tube and in time produce a deposit that prevents the gasket from sealing tightly. Clean off any deposit on the gasket disc with a cloth soaked in warm water and detergent. Do not scrape with a knife or other metal scraper as you may damage the silicone rubber seal. Clean off any deposit on the end of the tube by using a putty knife. Any accumulation in the tube should also be removed by using the ash rake as described in Step 7 of Weekly Cleaning Procedure.

If the silicone rubber gasket shows evidence of deterioration it should be replaced. When requesting a replacement, be sure to specify the size (diameter) of gasket you require.

To replace the gasket simply remove the center bolt and nut as indicated in the exploded assembly in this manual. Do not firmly tighten the nut on re-installation as the new gasket needs some slight wobble to seal properly over the air inlet tube.

YEARLY CLEANING

Following is the recommended procedure for yearly cleaning:

1. Clean the heat exchanger.
 - ✓ Remove the draft fan assembly.
 - ✓ Use a wire brush or scraper to cleanout the heat exchanger.
2. Clean the cyclone ash collector.

- ✓ Remove the top connecting flange from the cyclone.
- ✓ Clean the inside of the main body and funnel of the cyclone with a wire brush.
- ✓ Clean the tube that connects the cyclone to the boiler.
- ✓ Clean the boiler exit port where the cyclone attaches.

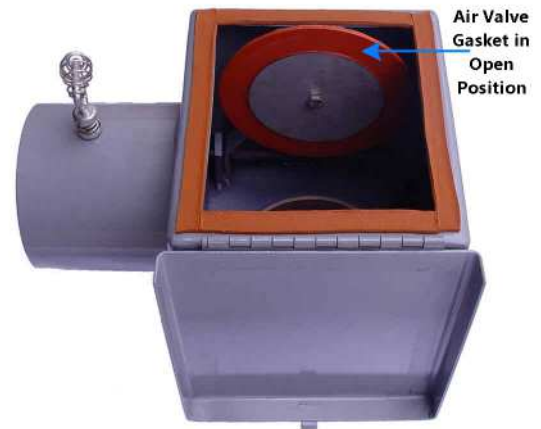

Air Valve Gasket

AIR VALVE MOTOR REPLACEMENT

Removing Old Damper Motor

1. Using the supplied Allen wrench, crank the motor to the full open position.
2. Use a 10 mm wrench to loosen the mounting bolt.
3. Remove Motor.

Installing the New Damper Motor

Note: Before starting this procedure make sure that the spring return will operate in the correct direction. To change the direction, just remove the clip that holds the clamp in place. Pull the clamp out flip the motor over and reinstall the clamp making sure that the arrow is pointing at the 0° mark. Reinstall the clip.

1. Use the Allen wrench to crank damper motor actuator to the 90 degree position. While holding the actuator at 90 degrees use a screw driver to twist locking mechanism which will hold actuator in position.
2. Place motor onto air valve.

3. Manually move the air valve disc to the open position, (see Figure 12) ensure that the jaws on the clamp align with the contour of the shaft as shown in Figure 11.

4. Tighten 10 mm bolt.

5. Using the Allen wrench, release the lock. This is accomplished by rotating the wrench in the direction of the arrow one quarter turn and then let go. The motor will then rotate to the closed position.

6. Inspect to insure that the air valve is sealed properly. The disc should have pressure allowing for a complete seal against the air intake collar.

7. It is very important that when placing the red end cap on the motor. The pins must align properly. If the pins do not align properly you will experience issues as such.

- ✓ Motor may not operate.
- ✓ Green Indicator light may not turn on when damper is in the open position.



Air Valve Motor Clamp Alignment



Air Valve Disk in Open Positioning

DOOR ADJUSTMENT

For proper operation of the Wood Gun™, it is important to have an effective seal of the loading door and cleanout door. All have a simple adjustment mechanism on the hinge plate and latch keeper that permits the door to be adjusted as the gasket compresses during service. To adjust the hinge, open the door, loosen the bolts that hold the hinge plate, and bump the door toward the doorframe and tighten the bolts. Be careful not to tighten so much as to prevent the latch side from closing properly.

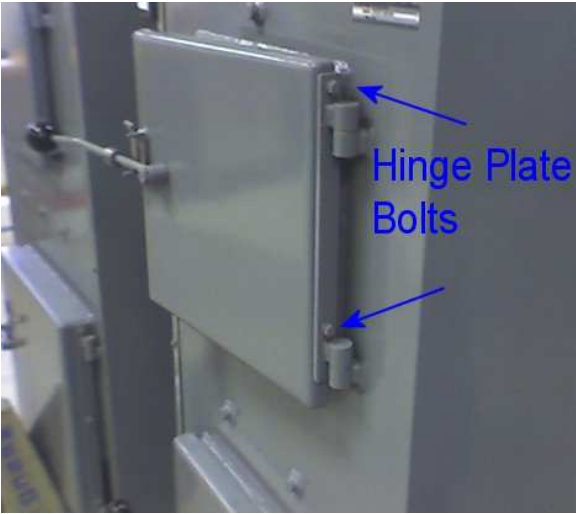

Door Hinge Plate Adjustment

To adjust the latch side of the door, remove the two bolts that secure the latch keeper in place and remove one of the spacer shims. Shims are inserted at assembly. Remove the thin one first and if more adjustment is required at a later time, then it can be used to replace the thicker one to gain the additional adjustment.



Door Latch Shims

A good method to use when trying to determine if the doors are sealing properly is to coat the doorframe edge with chalk or similar marker and close the door against the frame. Any unmarked portion of the gasket indicates a low spot, which can be built up using the high temperature silicone sealant. Periodically lubricate the door handle wear pad door hinges and door handle with the grease.

LOAD DOOR SEAL REPLACEMENT

1. Allow door to completely cool before you touch or start installation, remove door.
2. Cut flat fiberglass tape (white tape) into 4 equal strips. The tape shall stop 1" from each corner.
3. Insert silicone tube into a Caulking Gun.



Load Door with Old Seal Removed and High Temperature Silicone

4. Run a small bead of silicone into door groove. Place strips of fiberglass tape in grooves only on the straight sides. Lay the strips in as shown below, falling short of reaching into the corners. This is necessary because when the preformed gasket bead is pushed into place, it naturally expands outward away from the door where it is forced to bend around the corners.



Load Door with Fiberglass Braid Tape

5. Run a small bead of silicone on top of the fiberglass tape in the entire length of the door groove.



Load Door with Fiberglass Braid Tape and More High Temperature Silicone

6. Start the gasket in the middle of the hinge side. Squeeze the gasket into place on top of the bead of silicone. The rounded side faces downward towards the silicone. The whole length of the door groove should be filled with gasket. The gasket should have an even plane around the entire top surface. Be sure to squeeze the gasket into the groove evenly around the entire door to prevent any raised or uneven areas. These appear as bumps in the contour of the silicone bead.



Adding Preformed Silicone Bead to Door

7. The gasket should meet evenly (if it doesn't you may trim excess). Place a small amount of silicone on one of the edges to create a seal.



Marking to Trim

Trimming Preformed Silicone Bead



Adding High Temperature Silicone to Butt Joint of Trimmed Bead

8. Once the gasket is in place put a small amount over top of where the edges meet to create a seal. Smooth with a flat edge tool.



Finished Joint

9. Place a small amount of silicone around the corner edges and smooth with a flat edge tool.





Reinforcing Corners with High Temperature Silicone



Finishing the Corners

10. Allow silicone to dry for at least 2 days before reinstalling.

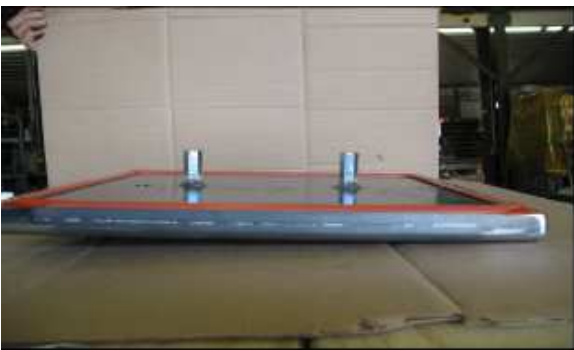

Finished, Level Bead

FRONT AND REAR INSPECTION DOOR HIGH TEMPERATURE ROPE INSTALLATION

The high temperature rope is made from fiberglass. You must wear gloves to protect your skin from getting strands of fiberglass embedded under the skin from handling.

1. The first step for installation is to make sure that the rope channel is clean. Remove any rust or loose debris from the channel.

2. Next, run a small bead of high temperature silicone in the center of the rope channel. A ¼ inch bead will work to hold the seal in place.

3. The rope sent from the AHS factory will be too long and will need to be trimmed to the proper length. This is important because you need to start and finish with a straight end. Use sharp scissors to cut the rope.

4. Start with a clean cut rope end. Place the rope end in the rope channel mid way up on the hinge side of the door. Press the rope in by hand from the center of the door to the first corner. Stretch the rope as much as you can while pushing it in. Go from corner to corner until reaching the end. When putting the two ends together tuck all loose ends down inside or between the rope ends. The rope should protrude about 3/8" above the door frame.

5. Gently tap the rope with a mallet to push it in to position. It is very important that the tool you use does not cut the rope as you tap it into place. If you do not have a mallet, use a wooden block and hammer.

6. Look over the door to find any high spots or bumps in the seal. Use the mallet to tap any and all of the high bumps down. This will give an even, straight surface the whole way around the door gasket.

7. The new gasket is now in place. The last step will be placing the door on the boiler and adjusting it as you would in a normal maintenance. The gasket will settle and will need adjustment in the next few weeks. It is recommended that the door adjustment should be checked every three days for the next few weeks.



Rear Inspection Door



Front Inspection Door

FAN ASSEMBLY

The fan-motor assembly may be removed by loosening the nuts from the studs.



Direct-drive fan attached to boiler

If the fan assembly gasket is damaged, all of the old material must be removed and a new gasket inserted. Use only 5/8 in diameter high-density fiberglass rope.

On units that have a shaft drive fan, the motor bearing will need to be replaced approximately every two years. On belt drive fans, the pillow block bearings and belt should be checked every three months. After the initial burn of two to six hours shut the boiler down and re-tighten the pillow block bearing set screws. To tighten the fan belt, loosen the four bolts that hold the motor to the bracket. Slide the motor down and re-tighten, being careful that the motor is properly aligned with the fan shaft. Some models have a hinged motor mount with adjusting screws. To check for proper alignment of the pulleys, use a straight edge lying across both pulleys.

Note: Pillow block fan shaft bearings are permanently sealed. Do not force grease into the grease fittings as you will break the seal and grease will run out when heated. DO NOT use a clay based grease in the pillow block bearings. A good synthetic grease is the best option. Most bearing failures are due to greasing too soon, too often, too much or with clay base grease.

After reattaching the fan motor assembly to the boiler, turn the fan over by hand to ensure that it does not bind. If a tight spot is evident, loosen the locking pillow block collars on the shaft and move the shaft in until the fan touches the boiler and mark the shaft. Then pull the shaft out until the fan touches the abrasion shield and mark the shaft. Finally, position the shaft midway between the two marks and re-tighten the collars. Be certain to replace the belt guard if it was removed for servicing.

▲ WARNING	
	DISCONNECT POWER
Be sure to disconnect power to the unit before servicing or removing the fan.	

DIRECT DRIVE FAN BEARING REPLACEMENT PROCEDURE

Make sure the power is turned off and/or disconnected. Disconnect the wire from the motor. Remove the motor end cap (3 screws). Remove the motor assembly by removing four 3/8" locknuts located along the outer edge of the motor mounting plate.



Fan Assembly Mount Points

It is a good idea to mark orientation of components for reassembly.

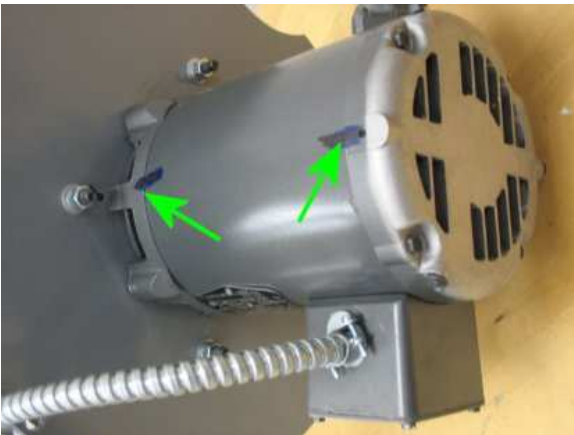

Mark Assembly Orientation

Place the fan assembly on your workbench with the fan facing up. Remove the two set screws from the fan hub. It might be a good idea to let a good

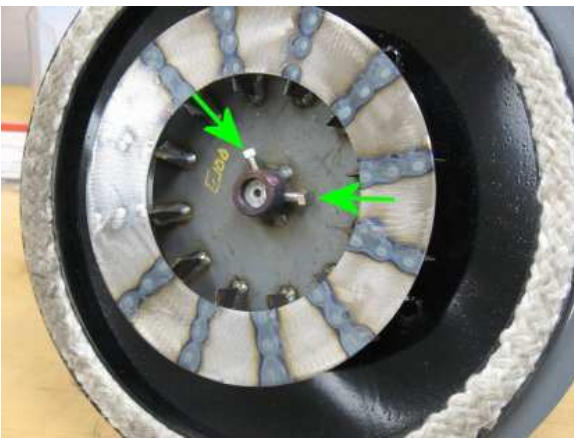

penetrant soak down into the area between the hub and the shaft. Letting it soak in for an hour or longer is recommended.

Fan Hub Set Screws

At this point, you have a choice of two methods for removing the fan. You may use a separate nut and jaw type puller, or you may use the economical AHS Fan Puller Tool. The photos below show each in turn, respectively. A bit of heat on the fan hub from a propane torch may be necessary.

Screw a one inch nut onto the threaded hub of the fan:



One Inch Nut for Pulling Fan

Using a jaw type puller, remove the fan from the motor shaft:



Jaw Puller at the Ready

Or, use the AHS Fan Puller:



AHS Fan Puller Tool



Closeup of Motor Mounting Bolts

To separate the motor housing you must remove the four bolts from the end of the motor opposite of the shaft. These bolts have a 5/16 bolt head.



AHS Fan Puller Tool at the Ready

Remove the (4) 5/16" nuts and washers from the motor plate allowing you to remove the abrasion shield and the heat shield from the motor plate. Be careful when removing the ceramic heat shield. It is very fragile. It is advisable to use a putty knife to separate the heat shield from the motor plate.



Motor Frame Assembly Bolts

Once these bolts are removed, tap the mounting end of the motor on the side with a rubber mallet, or use a regular hammer along with a block of wood. This will separate the bearing housing (end shield) from the motor body.

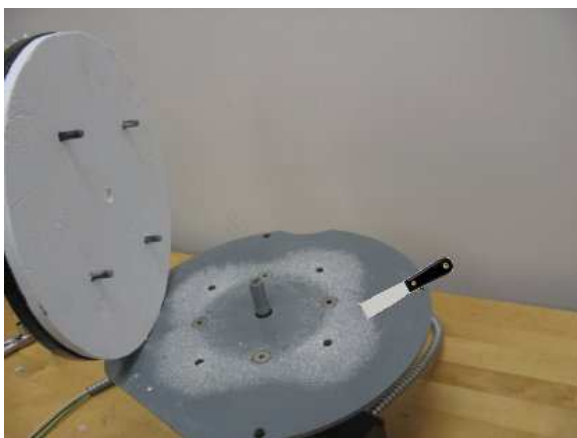

Separate Heat Shield from Motor Mount Plate

To remove the motor from the motor mounting plate use an allen wrench to remove the four motor mounting bolts that are counter sunk into the motor plate.



Loosening Motor End Shield from Motor

The end shield, along with the armature, can then be lifted gently out of the motor frame. Be sure that the beveled washer remains inside the motor housing.



Lifting the End Shield with Armature

Removing the two screws located beside the shaft will allow you to separate the shaft, with the still attached bearing, from the end shield.



Loosening Screws Securing Bearing to End Shield

Use a pulley puller, or our custom bearing puller tool [01-100-80 101] to remove the bearing from the shaft. You can use it on the motor bearing on either end of the shaft. The bearing on the shaft end is the one needing replacement in most instances. You may by routine choose to replace the bearing on the fan end every other time you replace the shaft bearing.



Jaw Puller at the Ready on Motor Bearing



AHS Bearing Puller

Place the new bearing on the shaft and drive it on with a hammer or mallet and a 3/4" pipe until it is fully seated. Use of the properly sized pipe or tube

allows you to drive the bearing onto the shaft by the inner race. Any significant force or impact applied to the seal or the outer race will possibly damage the bearing.

Place the bearing housing over the bearing and replace the two screws that were removed earlier.

Before setting the shaft and bearing housing back into the motor body make sure that the spring washer is still in place. It should be located in the rear bearing cavity.

After assembling the motor, spin the shaft to insure that it spins freely.

REFRACTORY REPLACEMENT

The refractory pieces in the bottom of the Wood Gun™ fuel chamber have two distinct shapes, as shown in the in the Appendix C: Exploded Parts Drawings.

CENTER BRICK

The Center Brick contain the slots through which burning gases are drawn by the induction fan. The 16 Inch center bricks are a common component in models E100 through the E250. The E100 also contains a single 11 3/8 in brick. This shorter brick should be placed to the front of the boiler. The center brick are subjected to the most severe flame erosion and highest temperatures and will most likely be the first refractory components to show signs of deterioration. Surface spalling is common under normal conditions and is not reason for concern.

The Center Brick refractory pieces should be changed every 10-15 cords of wood and must be ordered from Alternate Heating Systems. Center Brick are removed by simply lifting them out. They are likely to have become snug, as wood ash will settle into voids around them, making them tight. They are likely to require just a bit of effort to loosen them enough that they may be lifted upward. To accomplish this, open the front and rear inspection doors, remove the Center Plug, and use a rod (dowel rod, cut off broomstick or steel rod) with a hammer

to hit them from underneath through the inspection doors. Be careful that you don't hit the support ledges on the Side Brick when doing so. A few taps will loosen them sufficiently.

Once the old Center Brick are removed, clean ash from the Side Brick ledges. Place the Center Brick on the ledges, smooth side up. Center them over the Side Brick support ledges, with equal gaps on each side. If there are gaps between the bottom sides of the Center Brick and the ledges, such that burning gas will bypass the holes, repair the gaps with Troweleze Refractory Cement. Some wood ash dropped into the gaps can assist in sealing them off as well. If Side Brick erosion is severe enough to create a danger of the Center Brick collapsing into the center tunnel, and no repair is possible, consider use of the Steel Center Brick.

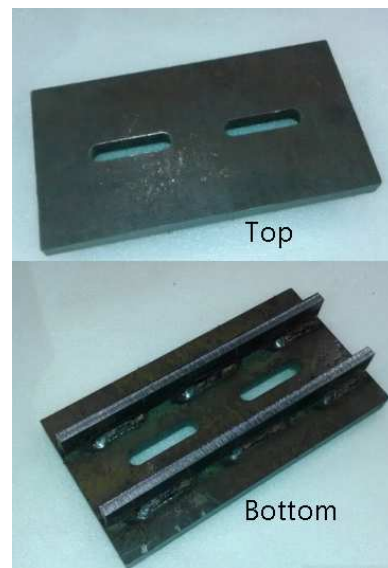

Steel Center Brick – 8 Inch

SIDE BRICK REFRACTORY REPLACEMENT

The large refractory (Side Bricks) are typically replaced every 10-15 years in residential boilers. They are usually held in place only by their own weight resting against each other and a refractory cement seal between the front and back boiler wall and the bricks. To remove, you will need to break the cement seal. It is a common occurrence for a brick to break in the removal process. If you are having trouble removing the old side brick follow these instructions. Remove the most deteriorated brick on each side. You may have to break it into smaller pieces to make it easier to remove. When you have an open gap in the brick you can then use a pry bar between the next two brick to break them loose. Once you have them loose, lift and remove them through the load door.

After the bricks are removed, check the ceramic blanket lining the bottom of the firing chamber for damage. If needed, this ceramic blanket can be ordered from AHS with your new refractory bricks. To install the new blanket, unwrap it and carefully mold it to the bottom of the firing chamber. When handling the blanket, you will want to use rubber gloves.

When replacing the refractory bricks, be careful to lay the pieces gently on the newly installed blanket since it may be easily torn or damaged. Alternately place right and left hand pieces so they will counter-balance one another. Be sure that the refractory tunnels and the center channels line up properly.

After all the refractory pieces are in place, check to see if there is any space between the refractory and the boiler wall and the ends. If there is more than 1/16 inch gap, fill it with "Troweleze" refractory cement. Allow the cement to dry for eight hours before firing the unit. If the gaps are very large, the refractory cement may not appear to dry completely in the eight hours allowed. You may go ahead and build a fire in the boiler to facilitate curing.

Please wear the proper safety equipment while performing this task. Proper equipment includes, work gloves, safety glasses, and steel toe boots.

1. Installing the dry insulation blanket is the first step. The blanket is already cut to size when it is shipped from AHS. The first piece that is installed will start at the front load door and extend toward the rear door two feet. Make sure that the blanket is centered and reaches the same distance up each side of the firebox wall. The next strip to be installed can range in depth from three and a half inches to another full two foot piece or somewhere in between. It depends on what size boiler that you're installing the bricks in. When this step is installed correctly there should be about a quarter inch to one inch gap from the boiler wall to the blanket. This will be true for the front and rear of the boiler. You may need to shift it one way or another to make it even. The last piece to be installed is an eight inch strip that runs the length of the boiler. It needs installed at the bottom center of the firebox. This will be where the side refractory brick edges will meet together.



New Ceramic Blanket in Place

2. Installing the side refractory bricks will be the next step. The refractory that was shipped to you is numbered. The numbers will either be 1, 2, 3, or 4. They are shipped so that when you install them you will have all the same number on one side. For example: If you were shipped eight side bricks and four of them had the number 1 on them and the other four had the number 4 on them. You would then install all the #4 bricks on the left side and all the #1 bricks on the right side. It does not matter

whether the # 4 bricks are installed on the right or on the left. It matters that all the numbers on the right are the same, and all the numbers on the left are the same. After the bricks are separated and you know which side they need to be installed in. Start by placing the first side bricks against the back wall of the boiler. Be careful not to slide the bricks across the dry blanket. When you have one brick on each side placed in the rear of the boiler. Set the next two bricks just inside the load door against the front wall of the firebox. If you are installing bricks into an E100 model Wood Gun. You will have two side bricks that are smaller than the others. They will be put in place next. They set against the two bricks in the back. All other boilers will have identical brick and they will also set against the back first two bricks. Repeat this step working forward until all the bricks are in place and meet up with the two bricks you placed against the front wall.



Positioning New Side Brick

3. After the bricks are placed in the boiler they will need aligned. Align the first row closest to the front inspection door. Basically both bricks should be even. You will be able to measure the two outside tubes. Measure from the top of the tube to the top of the door frame and make both measurements the same. Be sure that the bricks are touching at the bottom. Depending on the model some of the tubes will set just above the door frame. This is fine; the important issue is that they are both even. After the first two are set, match the next set up to the set in front of them. When this is completed properly the tunnels will be even and you will be able to move the ash rake through them.

4. Applying the Troweleze will be your last step. The Troweleze will fill in the gap between the brick and the vessel at the front and rear inspection door. This is also used to fill in and smooth out any transition from brick to brick. If there are areas in the tunnel that catch the ash rake just apply some Troweleze to smooth it out.

FUEL DIVERTER BLOCKS: AUTO FEED ONLY

Position the diverter block directly over the center of the center bricks. Start in the rear of the boiler and work toward the front of the boiler. Support each corner of the diverter block with a spacer support block. You may be able to use one spacer support block to support two blocks in the center where the diverter block butt against each other.

IMPORTANT: When cleaning or replacing the refractory, it is essential that the spacer bricks are properly positioned and the fuel diverter blocks are centered over the center bricks.

The spacer bricks may deteriorate in time allowing the fuel diverter to drop down onto the refractory combustion chamber bricks, thereby restricting airflow through the unit. Foreign material in the fuel such as sand, soil, metal or organic compounds may melt and fuse to the fuel diverter blocks causing restriction. Where unusual circumstances exist, special spacer bricks may be required to reduce the adverse effects of contaminated fuel. The gap under the fuel diverter block should be checked regularly to make sure blockage does not occur.

ADDITIONAL INFORMATION

For additional information on using your boiler safely, obtain a copy of the National Fire Prevention Association publication "Using Coal and Wood Stoves Safely", NFPA No. HS-8-1974. The address of the NFPA is 470 Atlantic Avenue, Boston, Massachusetts 02210. You may also visit:

<http://www.nfpa.org/codes-and-standards/free-access>

Appendix A: Boiler Specification Diagram

ADDITIONAL SPECIFICATIONS

Pressure Drop

Pressure Drop (Line Loss) within the boiler is less than the pipe rating of the pipe within the boiler, so there is no appreciable pressure drop.

Explanation of GPM Flow

The following are given as examples of gallons per minute water flow required to deliver hot water in

order to provide heating of a given number of degrees and at a certain BTU level:

- 500K BTU's at 20 degrees temperature differential requires 50 gallons per minute.
- 250K BTU's at 20 degrees temperature differential requires 25 gallons per minute
- 1M BTU's at 20 degrees temperature differential requires 100 gallons per minute.

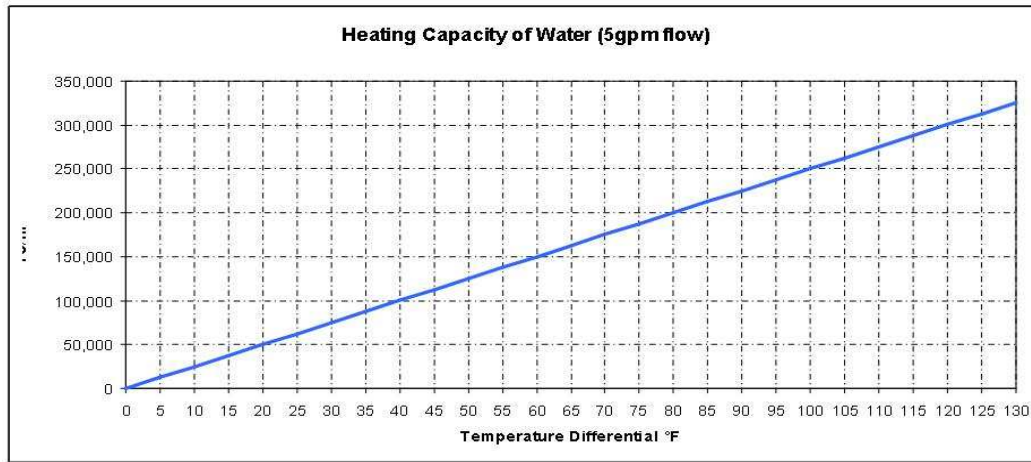

Wood Gun E Series Specifications

	E155	E140	E180	E250
BTU/Hour Max	150,000	200,000	230,000	350,000
BTU 8 Hour Avg Output*	100,000	140,000	180,000	250,000
Water Capacity	60 gallons	80 gallons	90 gallons	140 gallons
Fire Box Capacity	6.5 ft ³	10 ft ³	14 ft ³	22 ft ³
Fire Box Length	28"	32"	32"	48"
Standard Door Opening	14" x 14"	14" x 14"	14" x 14"	14" x 14"
Height	58"	64"	66"	74"
Width (cyclone removed)	26"	26"	31"	31"
Depth	44"	48"	48"	66"
Flue Size	6"	6"	6"	8"
Weight (w/o gas/oil)	1,400 lbs	1,650 lbs	2,100 lbs	3,000 lbs
Typical Heating Capacity**	3,000 ft ²	4,000 ft ²	5,000 ft ²	9,000 ft ²

*Based on loading firebox with seasoned firewood **Subject to building design/construction

Appendix B: Wiring Diagrams

REVISIONS				
NO.	DATE	BY	DESCRIPTION	

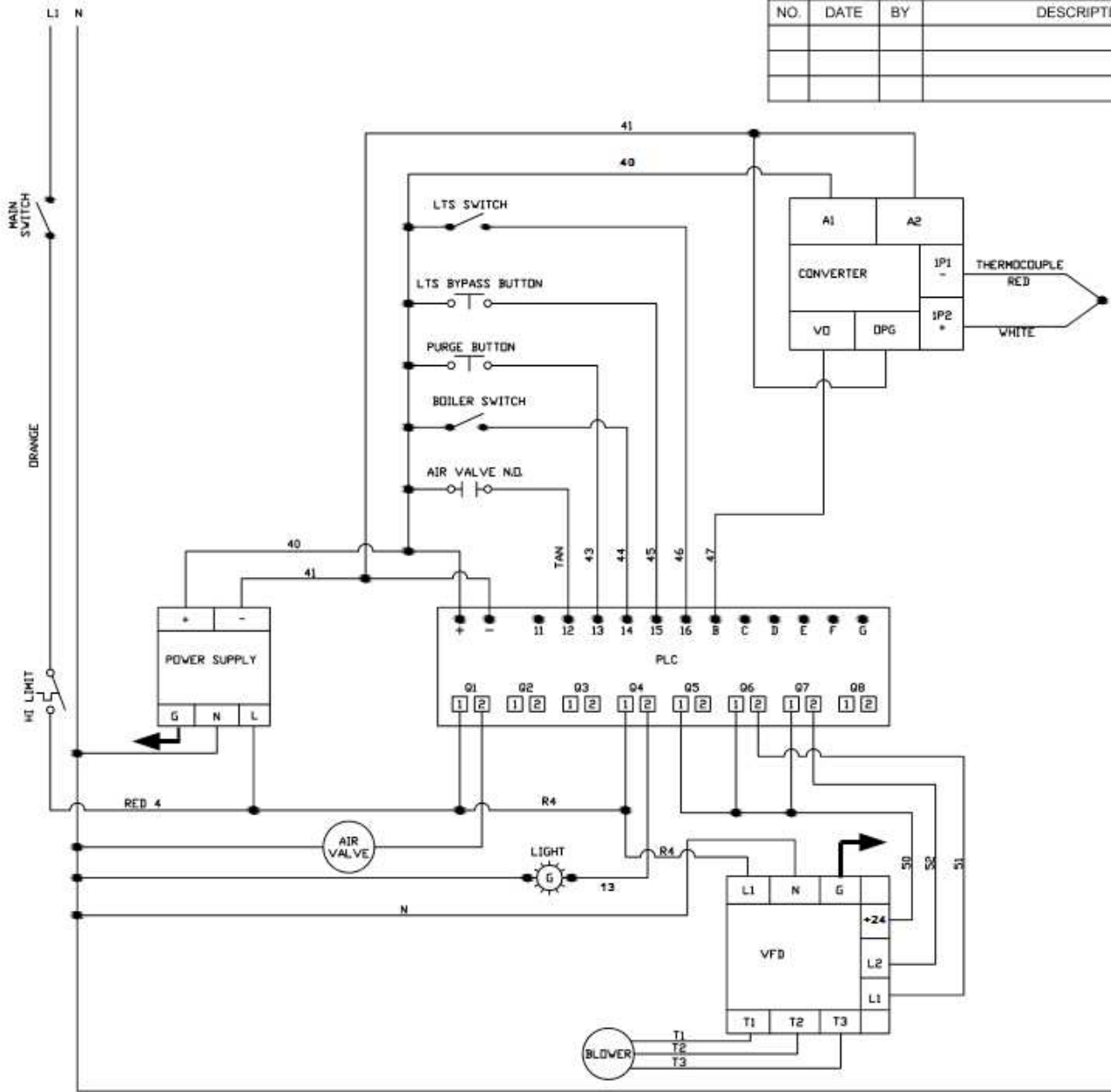

ALTERNATE HEATING SYSTEMS, LLC				
CONFIDENTIAL DOCUMENT				
MODEL: E155				
PART: EPA WOOD GUN				
DWG. #:	DRWN BY:	DATE:	APRVD BY:	DATE:
	NJG	11/18/15	NJG	11/18/15
MATERIAL: -				
TOLERANCES: DEC. ± .005" FRAC. ± 1/16" ANG. ± 2.0"				

Appendix C: Exploded Parts Drawings

Wood Gun™ Exploded Parts Drawing

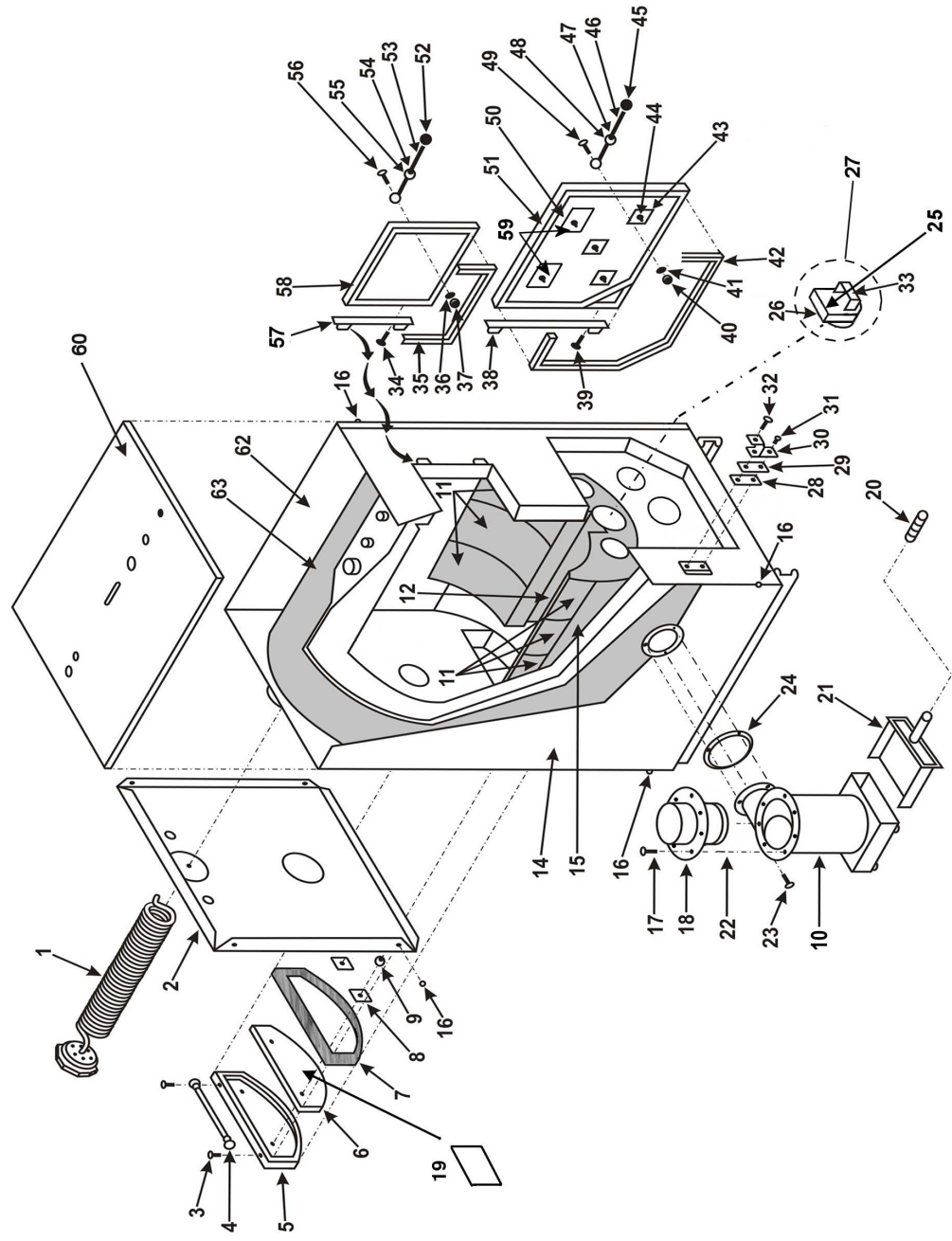

Parts Listing

KEY	DESCRIPTION	E100 SF	E140 SF	E180 SF	E250 SF
1	Domestic Hot Water Coil	100-002	100-002	100-002	100-002
2	Rear Insulation Jacket				
3	Rear Hinge Plate Mounting Bolt				
4	Rear Inspection Door Hinge Plate				
5	Rear Inspection door, complete	423-015	423-015	433-010	433-010
6	Rear Insp. Door Insulation Board	422-135	422-135	432-182	432-182
7	Rear Inspection Door Gasket, 1 Inch HD Fiberglass Rope	273-026-52	273-026-52	273-026-47	273-026-47
8	Door Board Washer	412-400	412-400	412-400	412-400
9	Door Board Retaining Bolt	200-016	200-016	200-016	200-016
10	Cyclone Body	423-033	423-033	423-033	433-011
11	Refractory Side Bricks	443-016/443-015	443-016	413-023	433-012
12	Refractory Center Bricks, 16 Inch	413-021	413-021	413-021	413-021
13	Model E100 Short Center Brick	443-010			
14	Left Side Insulation Jacket				
15	Ceramic Blanket	200-681	200-682	200-683	200-685
16	Insulation Jacket Mounting Screws				
17	Cyclone Top Flange Bolts				
18	Flue Connector Assembly				
19	Stainless Steel Rear Wear Plate	A422-232	A422-232	412-405	412-405
20	Ash Scoop rubber Grip				
21	Cyclone Ash Scoop	423-027	423-027	423-027	433-037
22	Cyclone Top Flange Gasket	200-052-38	200-052-38	200-052-38	200-052-58
23	Cyclone Mounting Bolt				
24	Cyclone Mounting Gasket	200-052-19	200-052-19	200-052-19	200-052-19
25	Center Plug – Replacement Ceramic Board	422-119	422-119	422-119	433-026
26	Ceramic Plug Refractory	423-012	423-012	423-012	433-013
27	Refractory Center Plug, Complete	423-025	423-025	423-025	432-144
28	Latch Shim (thick)	412-090	412-090	412-090	412-090
29	Latch Shim (thin)	412-093	412-093	412-093	412-093
30	Latch				
31	Latch Mounting Bolt				
32	Inspection Door Safety Stud				
33	Center Plug Handle	422-118	422-118	422-118	422-118
34	Load Door Hinge Plate Mounting Bolt				
35	Load Door Seal Kit	200-8011	200-8011	200-8011	200-8011
36	Door Handle Washer				
37	Door Handle Retaining Nut				
38	Front Inspection Door Hinge Plate				
39	Hinge Plate Mounting Bolt				
40	Door Handle Retaining Nut				
41	Door Handle Washer				
42	Front Inspection Door Gasket (1 IN Fiberglass Rope)	273-026-73	273-026-73	273-026-82	273-026-85
43	Insulation Board Washer	412-400	412-400	412-400	412-400
44	Insulation Board Retaining Bolt	200-016	200-016	200-016	200-016
45	Door Knob on Front Inspection Door	200-018	200-018	200-018	200-018
46	Front Inspection Door Handle				
47	½ in Snap Ring				
48	Door handle Roller				
49	Handle Attachment Bolt				
50	Front Inspection Door Insulation Board	423-134	423-134	412-174	432-183
51	Front Inspection Door, complete	A423-014	A423-014	413-009	413-009
52	Door Handle Knob	200-018	200-018	200-018	200-018
53	Load Door Handle				
54	½ in Snap ring				
55	Door Handle Roller				
56	Handle Attachment Bolt				
57	Load Door Hinge Plate				
58	Load Door	413-008	413-008	413-008	413-008
59	Front Inspection Door Wear Plates	A412-399	A412-399	A412-399	A412-399
60	Top Insulation Jacket				

**Wood Gun™ Exploded Parts Drawing
Fan Assembly**

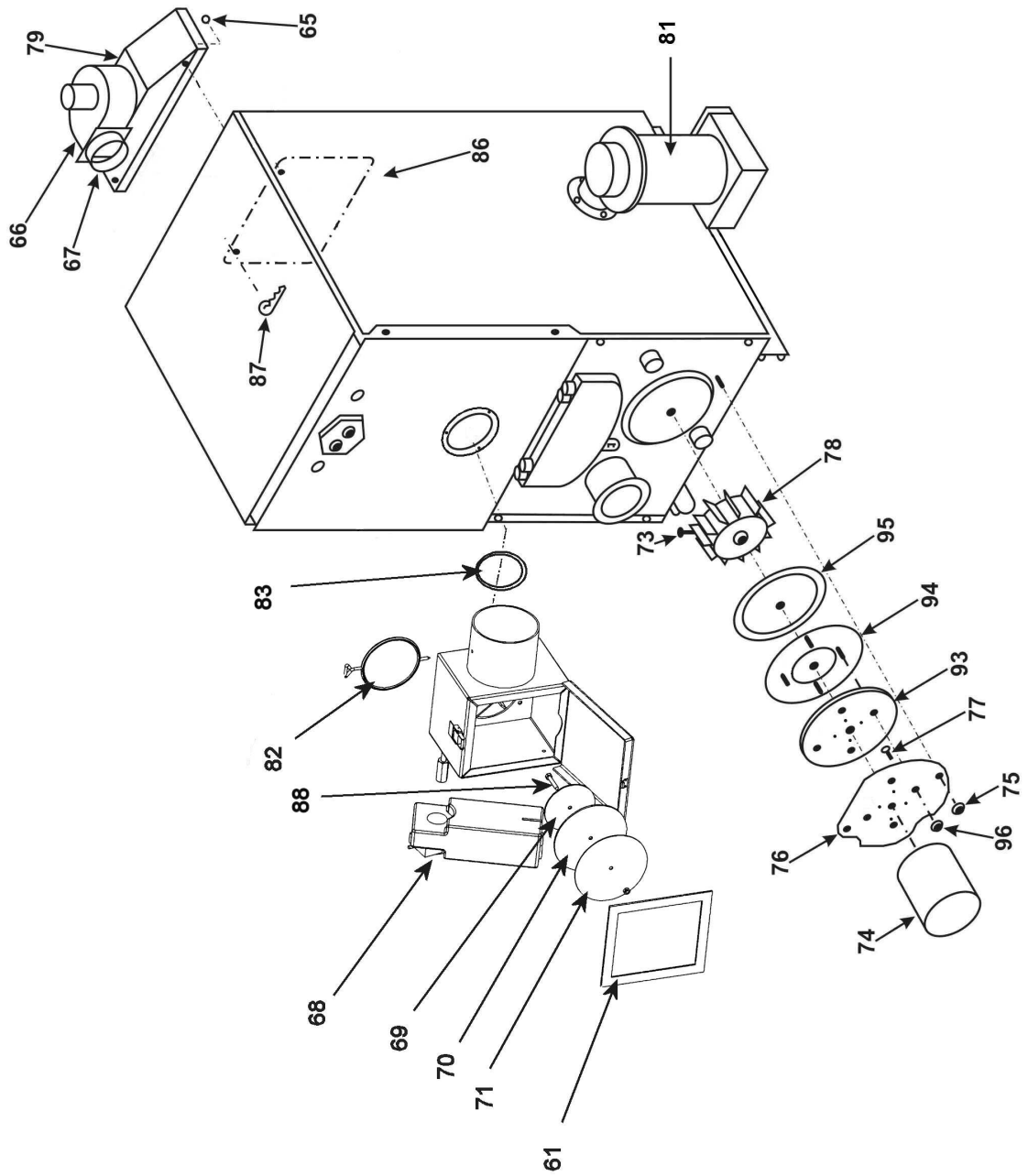

KEY	DESCRIPTION	E100	E140	E180	E250
61	Draft Box Lid Gasket	200-052-32	200-052-32	200-052-32	200-052-32
62	Right Side Insulation Jacket				
63	Fiberglass Insulation				
64					
65	Exhaust Hood Attachment Bolts				
66	Exhaust Hood Blower (wired)				
67	Exhaust Hood Connecting Flange Assembly				
68	Draft Motor	200-422B	200-422B	200-422B	200-422B
69	Inner Disc	412-132	412-132	412-132	412-132
70	Gasket Disk, Silicone Disc for Air Valve)	412-145	412-145	412-145	412-145
71	Air Valve Gasket Disc (Includes 70, 69)	413-040	413-040	413-040	413-040
72	Draft Motor Arm Assembly				
73	Fan Set Screw	200-499	200-499	200-499	200-499
74	Fan Motor	200-482	200-482	200-482	200-483A
75	Fan Cover Retaining Nuts				
76	Fan Cover Plate				
77	Motor Mounting Bolts/Screws				
78	Fan	A443-006	423-009	423-009	433-005
79	Exhaust Hood, complete	453-019	453-019	453-019	453-019
80	Draft Valve Assembly, complete				
81	Cyclone Assembly Complete	423-024	423-024	423-024	453-001
82	Cast Iron Damper 5 Inch				
83	Air Valve Box Mounting Gasket	200-052-21	200-052-21	200-052-21	200-052-21
84	Draft Box Mounting Bolts				
85	Air Valve Box Complete				
86	Smoke Flap	422-053	422-053	422-053	422-053
87	Smoke Flap Retaining Pin				
88	Gasket Disk Mounting bolt				
89	Gasket Disk				
90	Gasket Disk Washer				
91					
92					
93	Fan Ceramic heat Shield	422-125	422-125	422-125	432-185
94	Abrasion Shield	423-023	423-023	423-023	313-010
95	Fan Assembly Gasket	273-024-42	273-024-42	273-024-42	273-024-51

Appendix D: Troubleshooting Guide

This guide is intended to help you diagnose and repair basic problems with you boiler. If you believe your problem is serious or the problem persists after following all the procedures specified in this guide, contact AHS for support.

Problem	Possible Cause	Solution
1. Boiler overheating	<ul style="list-style-type: none"> a) Control malfunction b) Incorrect control setting c) Intake air valve not closing properly d) Excessive chimney draft e) Load door not sealing properly 	<ul style="list-style-type: none"> a) Replace malfunctioning control b) Adjust control setting c) Replace gasket or adjust linkage d) Reduce draft or see e) e) Adjust load door for proper seal, replace gasket if necessary
2. Back-puffing (Also see section on Charging Boiler with Wood and the Back-Puffing Checklist)	<ul style="list-style-type: none"> a) Burn cycle too long/Too much wood b) Wood too small and/or excessively dry c) Improper loading of fire box d) Improper starting of wood 	<ul style="list-style-type: none"> a) Fill with less wood to shorten burn cycle b) Load larger fuel with higher moisture content c) Follow proper loading procedure d) Follow proper starting procedure so as to attain high refractory temperatures
3. Smoke visible at stack	<ul style="list-style-type: none"> a) Refractory not hot enough b) Refractory not properly sealed in fuel chamber c) Center cleanout plug not properly sealed d) Leaking load door e) Leaking air valve f) Ash or charcoal buildup on or in refractory 	<ul style="list-style-type: none"> a) Allow refractory to come up to operating temperature; refer to instructions for building a fire b) Seal refractory with "Trowleze" refractory cement. c) Replace damaged ceramic pad at center cleanout plug d) Check doors for airtight seal e) Repair/replace air valve gasket disc f) Clean ash from boiler. See "weekly maintenance routine"
4. Fire goes out	<ul style="list-style-type: none"> a) Boiler not cycling frequently enough (refractory cools to below kindling temperature) b) Wood bridging in fuel chamber 	<ul style="list-style-type: none"> a) Increase heat load or install draft cycle timer (contact AHS) b) Reposition wood (always load wood length-wise front to back in chamber)
5. Smoke leakage at doors	<ul style="list-style-type: none"> a) Improper gasket seal b) Door not tight enough, or is out of adjustment 	<ul style="list-style-type: none"> a) Repair seal with high temperature RTV sealant added at low point on door gasket b) Adjust door
6. Fan vibration	<ul style="list-style-type: none"> a) Bearing or motor loose b) Fan out of balance c) Creosote buildup in area of fan impeller 	<ul style="list-style-type: none"> a) Tighten all bolts b) Inspect fan for damage c) Raise return water temperatures or use drier wood
7. Excessive water in the cyclone drawer (Also see condensation checklist)	<ul style="list-style-type: none"> a) The stack temperature may not be high enough. b) The fire box is being filled too full for the heat demand. c) There may be a blockage in the flue, cyclone, heat exchanger, or refractory. d) The wood logs are too large and/or has high moisture content. e) Load door seal or air valve seal is leaking 	<ul style="list-style-type: none"> a) The boiler should be in an insulated room. The flue stack needs to be insulated (If the room is typically cold.) b) Fill the fire box only half full or enough to burn for eight hours or less (shorten cycles). c) Remove ash from fire box and refractory. Clean the heat exchanger, cyclone, or flue.

	f) The boiler water temperature is too low or Water temperature difference between supply and return may be more than 20°F	d) Burn smaller wood, split wood, and/or dryer wood. Build a hotter fire. Remember that more wood does not always equate to more heat. e) Adjust and/or replace load door seal and/or Air Valve f) Raise the boiler operating temperature, (Max 200 ^e F)
8. The boiler burns more wood than usual	a) The wood has a higher moisture content level than normal. b) The wood is dry but has less weight per piece of wood (soft wood). c) The heat exchanger needs cleaned.	a) Try burning drier wood. b) Try burning hard wood. c) Clean the heat exchanger.
9. The pressure relief valve is releasing (Boiler pressure keeps rising)	a) Pressure reducing valve is malfunctioning. b) There is not enough expansion capacity. c) The domestic coil is leaking.	a) Replace pressure reducing valve. b) Add an expansion tank or replace a malfunctioning one. c) Replace or isolate the domestic coil.
10. There is smoke or creosote leaking out of air inlet connection. (Pre-2014 Boilers)	a) The air valve assembly has been moved or knocked out of position.	a) Reposition and tighten the air valve and reseal the sleeve where enters the boiler. Be careful not to knock the air valve out of position when loading fuel into the boiler.
11. There is excessive creosote buildup on boiler vessel located behind the lower front inspection door area.	a) The fire box is being filled too full for the heat demand. b) There may be a blockage in the flue, cyclone, heat exchanger, or refractory. c) The wood logs are too small and/or have very low moisture content. d) Load door seal or air valve seal is leaking. e) The boiler is operated with water temperature too low. The stack temperature may not be high enough.	a) Fill the fire box only half full or enough to burn for eight hours. b) Remove ash from fire box and refractory. Clean the heat exchanger, cyclone, or flue. c) Burn larger wood, unsplit wood, and/or green wood. d) Adjust load door, fix, or replace air valve. e) Raise the boiler operating temperature to 180-190 F
12. Steel has etching or pitting	a) Heating domestic water in the summer time with a carbon steel boiler.	a) Increase operating temperature in boiler. Only use small amounts of very dry wood to burn straight through the fuel charge with no cycling.

Index of Photos and Illustrations

Cyclone Attachment.....	7	Finished Joint.....	34
Proper chimney connection.....	10	Reinforcing Corners with High Temperature Silicone	
Stove pipe passing through wall.....	10	34
Pressure Relief Valve.....	11	Finishing the Corners.....	35
Pressure regulating valve and backflow prevention		Finished, Level Bead.....	35
valve configuration.....	11	Rear Inspection Door.....	35
Three Mixing Valve: Return Water Protection.....	12	Front Inspection Door.....	36
Photo: Low Water Cutoff Installation.....	12	Direct-drive fan attached to boiler.....	36
Plumbing – Coil in Series.....	14	36
Plumbing – Coil in Parallel.....	15	Belt-drive fan assembly removed from boiler and	
Figure: Domestic Coil Tempering Valve.....	15	showing white gasket.....	36
Plumbing – Coil with circulator.....	15	Fan Assembly Mount Points.....	37
E180, E250 Oil Burner.....	16	Mark Assembly Orientation.....	37
E100, E140 Combustion Chamber.....	16	Fan Hub Set Screws.....	37
Photo: (Smoke flap).....	18	One Inch Nut for Pulling Fan.....	38
Photo: (Smoke flap installed).....	19	Jaw Puller at the Ready.....	38
Automatic and Manual Dampers.....	22	AHS Fan Puller Tool.....	38
EPA Side Tunnel Plug.....	23	AHS Fan Puller Tool at the Ready.....	38
EPA Side Tunnel Plug Install.....	23	Separate Heat Shield from Motor Mount Plate.....	38
Air Valve Gasket.....	31	Closeup of Motor Mounting Bolts.....	38
Air Valve Motor Clamp Alignment.....	32	Motor Frame Assembly Bolts.....	39
Air Valve Disk in Open Positioning.....	32	Loosening Motor End Shield from Motor.....	39
Door Hinge Plate Adjustment.....	33	Lifting the End Shield with Armature.....	39
Door Latch Shims.....	33	Loosening Screws Securing Bearing to End Shield	39
Load Door with Old Seal Removed and High		Jaw Puller at the Ready on Motor Bearing.....	40
Temperature Silicone.....	33	AHS Bearing Puller.....	40
Load Door with Fiberglass Braid Tape.....	33	Steel Center Brick – 8 Inch.....	41
Load Door with Fiberglass Braid Tape and More		New Ceramic Blanket in Place.....	42
High Temperature Silicone.....	34	Positioning New Side Brick.....	43
Adding Preformed Silicone Bead to Door.....	34	Wood Gun Air Inlet Ducting Installations.....	64
Marking to Trim.....	34	Wood Gun in Primary/Secondary System.....	65
Trimming Preformed Silicone Bead.....	34	Operating an Alternate Heating Systems Boiler in	
Adding High Temperature Silicone to Butt Joint of		Tandem with Existing Boiler.....	66
Trimmed Bead.....	34		

Appendix F: Boiler Piping and Ducting Examples

Wood Gun Air Inlet Ducting Installations

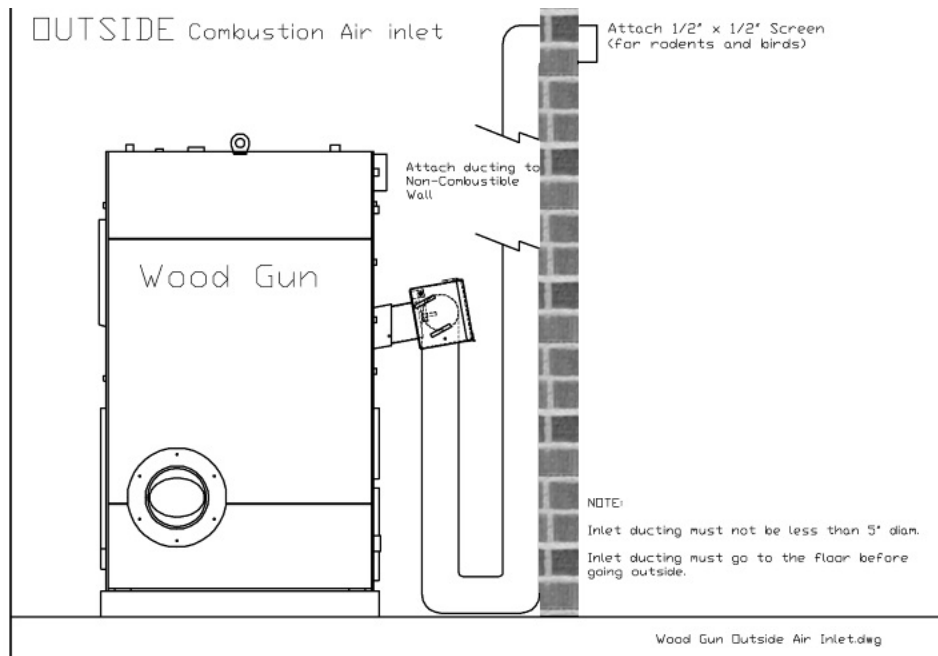
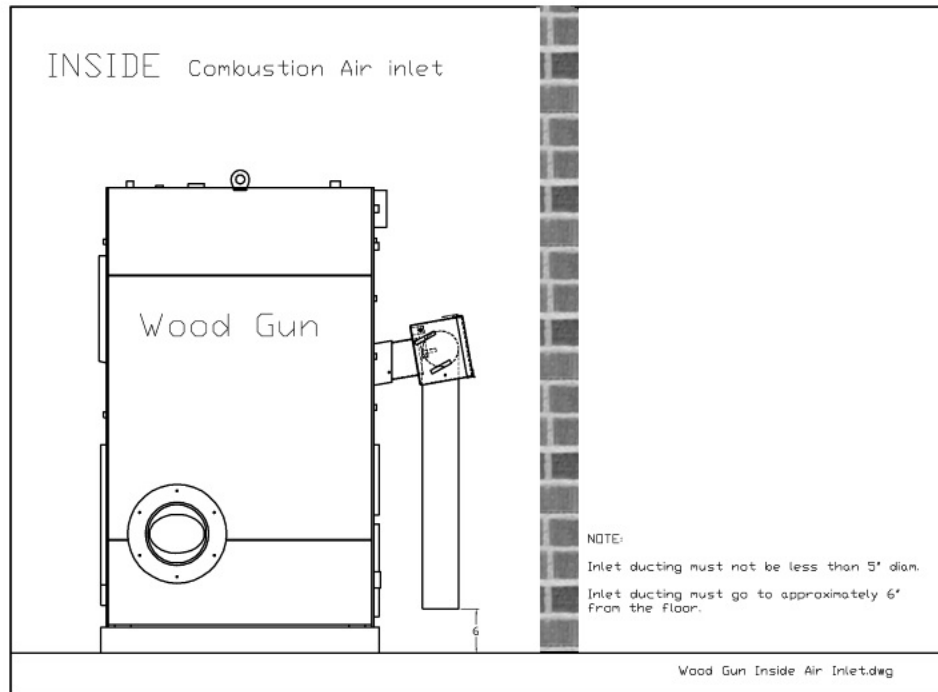

Wood Gun in Primary/Secondary System

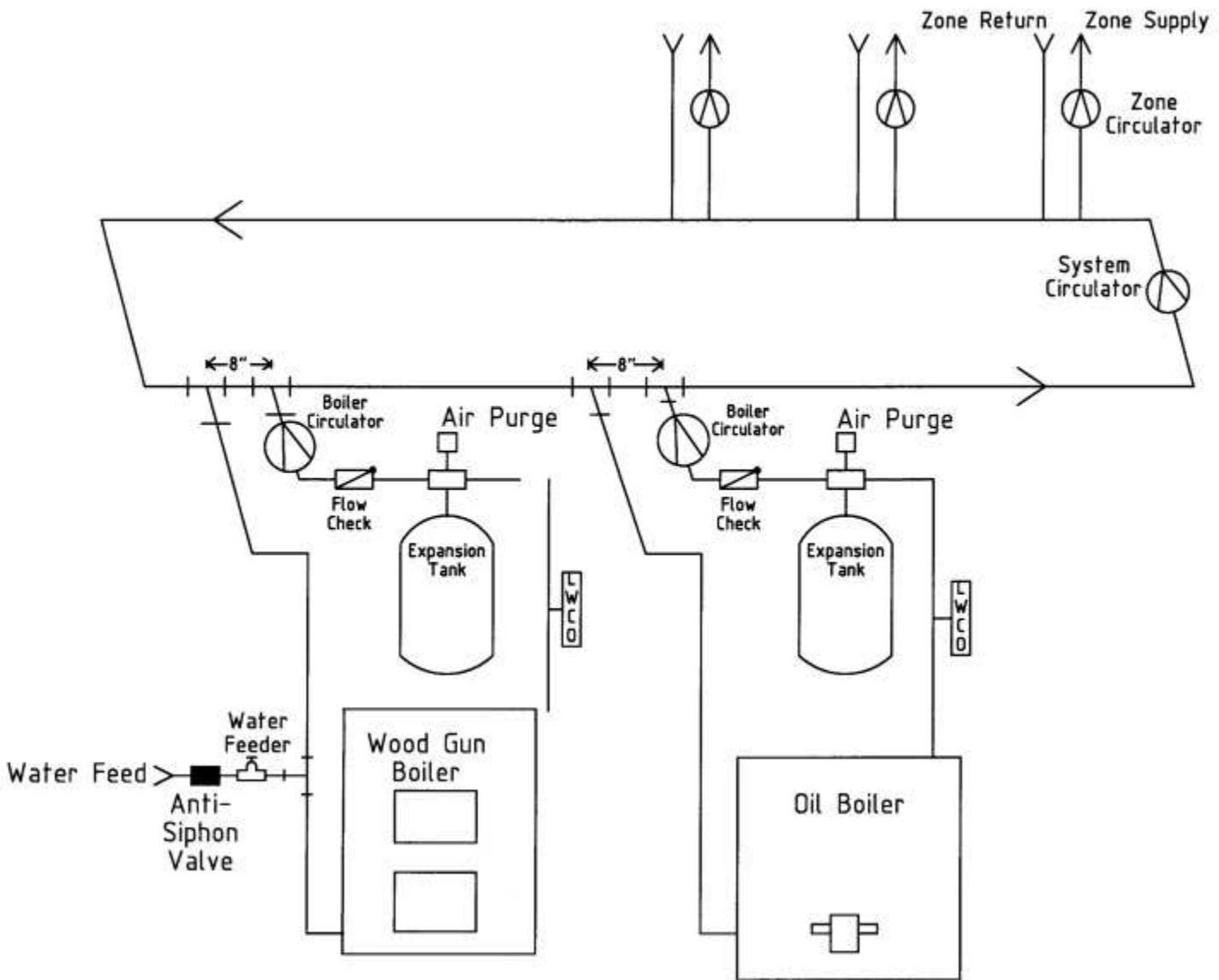

Note:

1. A call for heat from any zone activates Boiler Circulators, System Circulator and Zone Circulator.
2. Each Boiler Circulator is also controlled by a low limit to prevent operation when the Boiler is cold.
3. Dump zone operation will activate one or more zones, System Circulator and Boiler Circulator.
4. Do not bypass temperature supply control system on radiant heat system. In radiant heat applications, permit activation of a call for heat but allow system controls to regulate water temperature.

Not all system components, valves and devices are shown in this drawing. Actual conditions and application requirements will vary. Please consult a heating expert or your Alternate Heating Systems for additional information.

Operating an Alternate Heating Systems Boiler in Tandem with Existing Boiler

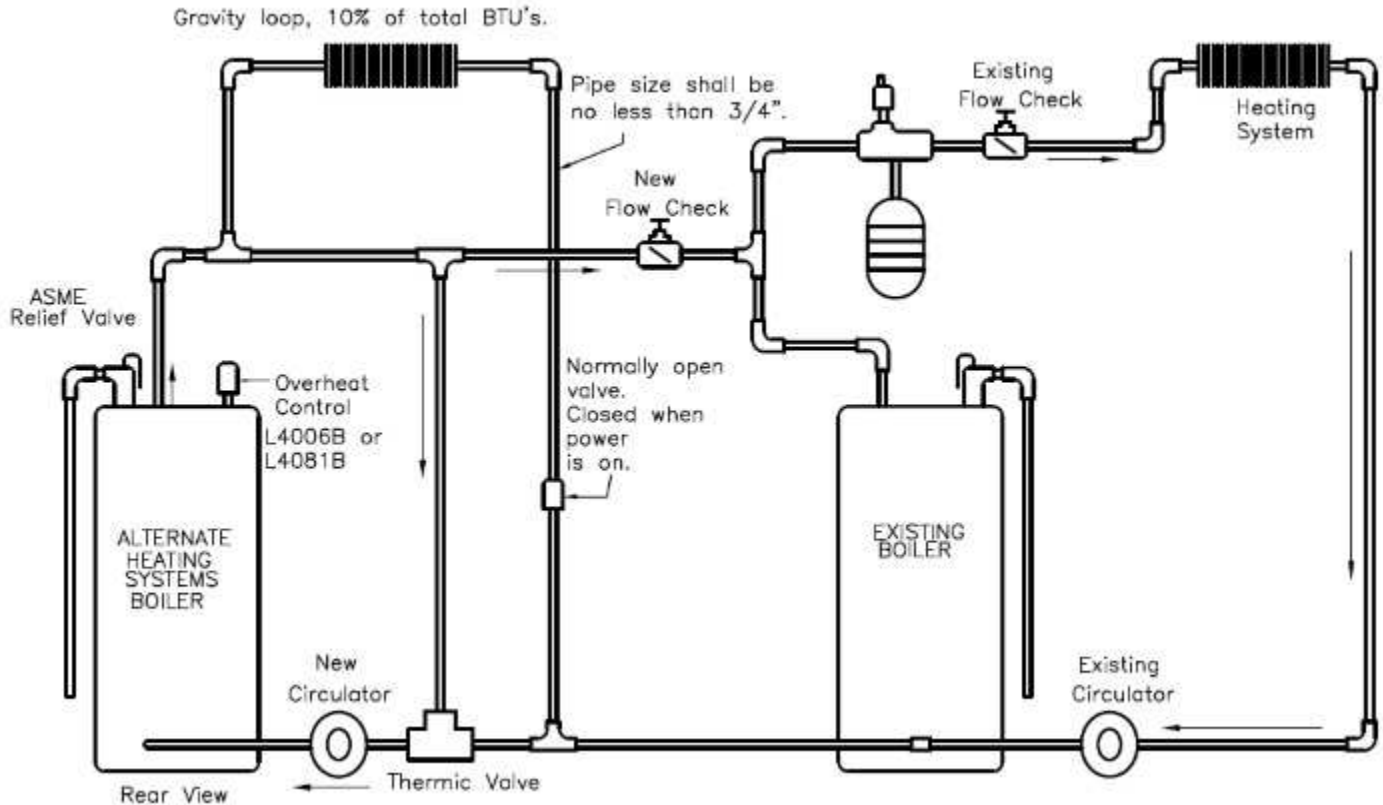

Note: The above illustrates one possible method of connecting the Wood Gun™ with an existing boiler. This connection is as follows: using a small circulator (and with the backup boiler piped into the return tapping) run another pipe from the supply tapping T, of the Wood Gun™ to the supply line, of the existing boiler on the lower side of the flow control valve. A minimum of 1 in diameter pipe should be used for this connection on the model E100 – E140. The pipe size must be determined by taking into account the distance involved and flow required. The new circulator should be wired to the power for the Wood Gun. When power to the Wood Gun is on, the circulator should be running. An alternate option is to attach a strap on aquastat on the Wood Gun supply line that closes on temperature rise. This will automatically activate the pump at a given temperature. Overheat control (as pictured above) on the Wood Gun is optional

LIMITED WARRANTY

WOOD GASIFICATION BOILERS:

E100 SF

E140 SF

E180 SF

E250 SF

The manufacturer, ALTERNATE HEATING SYSTEMS, warrants to the original owner, for the periods specified below, that the boiler to which this warranty applies is free from defects in materials and workmanship when installed, operated, and maintained in accordance with the printed instructions supplied with the unit.

A. WHAT IS COVERED AND FOR HOW LONG (all from date of original installation)

- 1) VESSEL:
STAINLESS STEEL BOILER VESSEL, TWENTY (20) years pro-rated (pro-rated as follows: 1st to 10th year – full: 11th year – 40%: 12th year - 30%: 13th year – 20%: 14th year – 10%: 15th – 20th year – 10%). This does not cover any corrosion or deterioration in boiler vessel due to improper pH levels in water or oxidized water (heating systems that have plastic piping).
- 2) Doors (excluding gaskets, knobs, and ceramic insulation board), draft regulation mechanisms, insulation jacket, draft fan assembly (excluding ceramic heat shield), stack/cyclone assembly, firebox refractory side brick and center brick – ONE (1) year.
- 3) All electrical and plumbing components and controls such as temperature/pressure gauge, safety relief valve, aqua stat controllers, electric motor, domestic hot water coil, oil burner, fan shaft bearings, timer, draft motor, etc. purchased by Alternate Heating Systems from other manufacturers are Limited to warranties offered by those manufacturers, typically One (1) year.
- 4) V-belt, pulleys, ceramic board door and fan heat shields, ceramic blanket firebox lining, fasteners, sight glass, smoke flap, door gasket and silicone rubber seal, door handle knobs, paint, wiring, and wiring devices -Thirty (30) days.

B. WHAT WE WILL DO AND NOT DO

- 1) Alternate Heating Systems will repair and replace, at our option, units or component parts found defective after inspection by Alternate Heating Systems or our authorized representative during the periods outlined above.
- 2) Alternate Heating Systems SHALL NOT BE LIABLE UNDER THIS WARRANTY IF:
 - a) the unit or any of its component parts have been subject to misuse, alteration, unauthorized repair, neglect, accident, or damage from handling.
 - b) the unit is not installed, operated and maintained in accordance with the printed instructions supplied with the unit and in accordance with local plumbing and/or building codes.
 - c) the unit is operated above its rated output which is shown on the nameplate attached to the unit and listed in Alternate Heating System's printed literature.
 - d) the unit is fired with fuels other than those recommended by Alternate Heating Systems. This includes fuels recommended by dealers and distributors selling Alternate Heating Systems products if these are not fuels recommended by Alternate Heating Systems.

C. WHAT THE CUSTOMER MUST DO

- 1) Contact the dealer who sold you the unit.
- 2) If said dealer cannot be located, contact any other Alternate Heating Systems dealers in your area.
- 3) If you are unable to locate a dealer, submit your warranty claim directly to Alternate Heating Systems at the address listed below.
- 4) When you make an inquiry or warranty request, be sure to include the following information:
 - a) Unit model number
 - b) Serial number
 - c) Date of installation
 - d) Dealer's name
 - e) Type of fuel burned
- 5) The OWNER and not Alternate Heating Systems or its dealers will be liable for the following costs involved in repair or replacement of the defective unit or component part
 - a) All necessary costs in returning the defective unit or component part to the factory or other location designated by Alternate Heating Systems.
 - b) All freight and delivery costs of shipping a new or required unit or replacement component part to the owner.
 - c) All labor and other costs incurred in the removal of the defective unit or part and installation of a new or required unit or part.
 - d) Any material required to complete installation of new or required unit or replacement part.

D. LIMITATIONS AND STATE LAW RIGHTS

- 1) Alternate Heating Systems neither assumes nor authorizes any representative or other person to assume for it any other obligation or liability in connection with its products other than expressly written here.
- 2) Implied warranties of merchantability and fitness for a particular purpose are limited to the duration of this LIMITED WARRANTY.
- 3) Alternate Heating Systems shall not be liable for any incidental or consequential damages such as water, smoke or heat damage to property arising directly or indirectly from any defect in its products or their use.
- 4) Some states do not allow limitation on how long an implied warranty lasts and the exclusion or limitation of incidental or consequential damages, so the above limitations and exclusions may not apply to you.
- 5) This warranty gives you specific legal rights. You may also have other rights, which vary from state to state.
- 6) The remedies set forth herein shall be the exclusive remedies available to the owner.

ALTERNATE HEATING SYSTEMS

2393 Little Egypt Rd
Harrisonville, PA 17228

IMPORTANT: READ AND KEEP IN YOUR POSSESSION!